

**NOTICE OF MEETING
CITY COUNCIL OF THE CITY OF GALVESTON
THURSDAY - FEBRUARY 27, 2025 - 5:00 P.M.
COUNCIL CHAMBERS - CITY HALL
823 ROSENBERG, GALVESTON, TEXAS
TELEPHONE: (409) 797-3510**

REGULAR MEETING AGENDA

1. DECLARATION OF A QUORUM AND CALL MEETING TO ORDER
2. ROLL CALL
3. INVOCATION
Rev. Richard Rhoades - First Lutheran Church
4. PLEDGE OF ALLEGIANCE
American Flag

Texas Flag - *Honor the Texas Flag. I pledge allegiance to thee, Texas, one state, under God, one, and indivisible.*
5. CONFLICTS OF INTEREST
6. PRESENTATIONS/REPORTS OF COUNCIL, OFFICER BOARDS, AND CITY MANAGER
- 6.A. Pursuant To Texas Government Code Section 551.0415, The City Council May Report On Any Of The Following Items:
 1. Expressions of thanks, gratitude, and condolences
 2. Information regarding holiday schedules
 3. Recognition of individuals
 - a. Mayor's/Monarch Pledge Day
 - b. Certificates of Recognition - I.L.A. Local 20, Family Service Center of Galveston County, Better Parks for Galveston
 4. Reminders regarding City Council events
 5. Reminders regarding community events
 6. Health and safety announcement

Documents:

[MLK DAY.PDF](#)

7. COMMUNICATIONS AND PETITIONS
Claims:25-004 - Audrey Dickson-Walker; 25-005 - Nicholas Gilmore; 25-006 - Celeste Taylor-Valasco; 25-007 - Edwardo Esquivel; 25-008 - Marcella Gallon; 25-009 - Eddie Calderas; 25-010 - Georgina Hullum; 25-011 - Darrell Singleton

Documents:

[CLAIMS FEBRUARY 2025_REDACTED.PDF](#)

8. PUBLIC HEARINGS

- 8.A. Consider For Approval An Ordinance Of The City Of Galveston, Texas, Changing The Zoning From Residential, Single-Family (R-1) Zoning District To Restricted Residential, Single Family (R-0) Zoning District On Various Properties Of The Sea Breeze Subdivision As A Restricted Residential, Single-Family (R-0) Zoning District. Properties Are Legally Described As Abstract 121 Page 48 Lots 1 Through 11 Sea Breeze And Abstract 121 Page 48 North 75 Feet Of Lot 12 (12-1) Sea Breeze, In The City And County Of Galveston, Texas. Planning Case Number 25P-004; Making Various Findings And Provisions Related To The Subject. (P. Milburn)

Documents:

[25P-004 CC STF RPT PKT WITH ORD.PDF](#)

- 8.B. Consider For Approval An Ordinance Of The City Of Galveston, Texas, Creating A Planned Unit Development (PUD) Overlay Zoning District In A Commercial (C) Zoning District To Develop An Auto Fueling Station Land Use On Property Commonly Known As 13722-14000 San Luis Pass Road / FM 3005, And Which Is Legally Described As Part Of Lots 32 And 45 (45-5), And Adjacent Abandoned Street, Trimble And Lindsey Survey, Section 3, In The City And County Of Galveston, Texas; Planning Case Number 25P-001; Making Various Findings And Provisions Related To The Subject; And Providing For An Effective Date. (C. Gorman)

Documents:

[25P-001 - CC RPT PKT WITH ORD.PDF](#)

9. PUBLIC COMMENT

- A. Agenda Items
- B. Non-Agenda Items

10. ORDINANCES (NOT REQUIRING PUBLIC HEARINGS)

- 10.A. Consider For Approval An Ordinance Of The City Of Council Of The City Of Galveston, Texas, Amending The Designated Meeting Days For The Year 2025 Of Joint Meetings With The Park Board Of Trustees And The Board Of Trustees Of The Galveston Wharves; Reserving The Right Of Council To Schedule Additional Meetings As Needed; Providing For Findings Of Fact And Providing For An Effective Date. (Brown)

Documents:

[ORD - CITY COUNCIL - AMENDED JOINT MEETINGS CALENDAR - 2025.DOCX](#)

11. CONSENT ITEMS - The Following Items Shall Be Considered For Action As A Whole, Unless One Or More Council Members Objects. The City Manager Is Authorized To Execute All Necessary Documents Upon Final Approval By The City Attorney.

- 11.A. Consider For Approval The City Auditor's Office Audit On Hotel Occupancy Tax For The 2025 Audit Plan. (G Bulgherini).

Documents:

[2025 AUDIT REPORT STR AND HOTEL.PDF](#)

- 11.B. Consider For Approval The City Auditor's Office Audit On Commercial Repair/Remodel Sales Tax Revenue For The 2025 Audit Plan. (G. Bulgerhini).

Documents:

[SAL2024 AUDIT REPORT.PDF](#)

- 11.C. Consider For Approval A Request Of The City Attorney For Retain The Services Of Peter Sapio Of The Doyle Law Firm For The Conduct Of Title Work Associated With He Pelican Island Bridge Project. (Legal)

Documents:

[SAPIO DOYLE ENGAGEMENT MEMO.DOCX](#)

- 11.D. Consider For Approval An Application By Madonna Mamerow To Place Her Art On A Public Sidewalk (Legal)

Documents:

[MAMEROWARTAPP.PDF](#)
[STAFF REPORT MADONNA MAMEROW APPLICATION.DOCX](#)

- 11.E. Consider For Approval A Resolution Of The City Of Galveston Authorizing Acceptance Of Additional Grant Funds From The Texas General Land Office (GLO), For The Beneficial Use Of Maintenance Dredge Material, Associated With A 1.7 Mile Long Beach Nourishment Project; Authorizing The City Manager To Execute All Required Documents, Upon Final Approval Of The City Attorney; Providing For Findings Of Fact And Providing For An Effective Date. (K. Clark)

Documents:

[CITY COUNCIL STAFF REPORT_ADDITIONAL FUNDS REQUEST_GLO GRANT \(02_17_2025\).PDF](#)
[RESOLUTION-USACE -ADDL FUNDING-CAP 204 BEACH NOURISHMENT.DOCX](#)

- 11.F. Consider For Approval Of An MOU Between The City Of Galveston And Broadway Monument LLC/ Mary Moody Northen Endowment For The Use Of The Lot Located At 2529 Sealy For Special Events, Training, And Educational Purposes. Authorizing The City Manager To Execute All Necessary Documents Upon Final Approval By The City Attorney. (M. Varela)

Documents:

[RES - MOU-FIRE DEPT USE OF LOT AT 2529 SEALY.DOC](#)
[MOU - USE OF LOT- 2529 SEALY - FIRE DEPT - MARY MOODY ENDOWMENT.DOCX](#)
[2025.02.05 MARY MOODY NORTHEN ENDOWMENT LOT MOU.PDF](#)

- 11.G. Consider For Approval The Ratification Of \$27,000 For The Emergency Demolition Of The Structure Located At 1604 Market In Galveston, TX. (N.Yeley)

Documents:

[STAFF REPORT FOR RATIFICATION ON 1604 MARKET.PDF](#)
[1604 MARKET INVOICE.PDF](#)

- 11.H. Consider For The Issuance Of Task Order #4 To Plexos Group, LLC For The Grant Administration Services Related To The Texas General Land Office (GLO) Community Development Block Grant – Mitigation (CDBG-MIT) For The South Shore Drainage Improvement Project In The Amount Of \$678,875.00 And Authorizing The City Manager To Execute All Necessary Documents. (T Wroblewski)

Documents:

[SOUTH SHORE PLEXOS TASK ORDER 4 STAFF REPORT.PDF](#)

- 11.I. Consider For Approval Changes To Membership And Rental Fees At McGuire-Dent Recreation Center, And Various Athletic Fields And Courts Under The Management Of The Parks And Recreation Department And Designating Special Revenue Accounts For Revenue Earned At Each Location; Authorizing The City Manager To Execute All Necessary Documents Upon Final Approval By The City Attorney. (B. Sanderson)

Documents:

[STAFF REPORT - RECREATION FEES \(2025\).PDF](#)

- 11.J. Consider For Approval The Acceptance Of A Donation Valued At \$1,500.00 From Josh's Benches For Awareness, In Collaboration With The American Foundation For Suicide Prevention, For A Park Bench That Raises Awareness Of Suicide Prevention, At Menard Park. Barbara Sanderson

Documents:

[STAFF REPORT - SUICIDE PREVENTION AWARENESS BENCH DONATION.PDF](#)

- 11.K. Consider For The Approval Of A Resolution Of The City Council Of The City Of Galveston Approving The Amended 2025 City Of Galveston, Island Transit Title VI Plan As Required By The Federal Transportation Administration And The Texas Department Of Transportation. (D. Smith)

Documents:

[RESOLUTION- TITLE VI.PDF](#)
[GIT TITLE VI POLICY 2025-2028 PACKET.PDF](#)

- 11.L. Consider For The Approval Of The Agreement For The Payment To The Galveston County Health District (EMS) For Emergency Medical Services That Will Be Provided During The 2025 Mardi Gras Event For A Total Of \$23,408 And Authorize The City Managers Staff To Execute The Document Upon Final Approval By The City Attorney. (D. Smith)

Documents:

[MARDI GRAS EMS 2025 PACKET.PDF](#)

- 11.M. Consider For The Approval Of The Purchase Of One New Spartan Fire Pumper For The Fire Department To Be Purchased From Metro Fire Apparatus Specialists Inc. Through Sourcewell Coop For A Total Extended Price Of \$1,128,886.27 And Authorize The City Manager To Execute The Contract Upon Final Approval By The City Attorney. (D. Smith)

Documents:

[FIRE PUMPER PURCHASE 2025 PACKET C.PDF](#)

- 11.N. Consider For The Approval Of A Prerequisite To Be A Recipient Of FTA Funding That Is Demonstrating The Legal Capacity To Carry Out The Project(S) Included In Federal Assistance Awards And Authorize The City Managers' Staff To Execute The Subject Item Upon Final Approval By The City Attorney. (D. Smith)

Documents:

[ISLAND TRANSIT LEGAL OPINION AND RESOLUTION PACKET.PDF](#)

- 11.O. Consider For The Approval Allowing The Purchasing Of Parts And Services Utilizing The Buy Board Cooperative Purchasing Contract With Siddons Martin Emergency Group (Contract 698-23/746-24) And Authorize The City Managers Staff To Execute The Agreement Upon Final Approval By The City Attorney. (D. Smith)

Documents:

[SIDDOSN MARTIN 2025 PACKET.PDF](#)

- 11.P. Consider Allowing The Purchasing Of Bulk Fuel By The Fleet Facility Utilizing The TASB Energy Cooperative Purchasing Contract With Sun Coast Resources And Authorize The City Managers Staff To Execute The Agreement Upon Final Approval By The City Attorney. (D. Smith)

Documents:

[SUN COAST COOP PACKET.PDF](#)

- 11.Q. Consider For The Approval Allowing The Purchasing Of Fuel Station Parts And Services Utilizing The Choice Partners Cooperative Purchasing Contract With Liberty Equipment Sales (Contract 24/016MR-03) And Authorize The City Managers Staff To Execute The Agreement Upon Final Approval By The City Attorney. (D. Smith)

Documents:

[LIBERTY EQUIPMENT SALES PACKET.PDF](#)

- 11.R. Consider For The Approval Allowing The Fleet Facility To Purchase The Listed Rolling Stock (Police Service Units) And Associated Equipment From Silsbee Ford Through Tips Co-Op For A Total Price Of \$422,663.90 And Authorize The City Managers Staff To Execute The Contract Upon Final Approval By The City Attorney. (D. Smith)

Documents:

[SILSBEE FORD POLICE PACKET B.PDF](#)

- 11.S. Consider For Approval A Resolution Of The City Council Of The City Of Galveston, Texas, Approving A Blanket Lighting Maintenance Agreement With The Texas Department Of Transportation (TxDOT) For A Continuous Lighting System Installation Project, Regarding Installation And Continued Maintenance Of A Continuous Lighting System In Areas Within The City Of Galveston; Authorizing The City Manager To Execute The Agreement And All Other Necessary Documents Upon Final Approval By The City Attorney; Directing The City Secretary To Send A Certified Copy Of This Resolution To The Texas Department Of Transportation; Providing For Findings Of Fact

And For An Effective Date. (R Winiecke)

Documents:

[TXDOT BLANKET LIGHTING MAINTENANCE AGREEMENT STAFF REPORT \(REV 1\).PDF](#)

- 11.T. Consider For Approval A Professional Services Contract With Freese & Nichols, Inc. (FNI) To Conduct The Engineering Design Of The Isla Del Sol Pump Station & 0.5 MG Ground Storage Tank (GST) Project For The City Of Galveston In The Amount Of \$829,688.00; Authorizing The City Manager To Execute All Necessary Documents Upon Final Approval By The City Attorney. (R Winiecke)

Documents:

[FREESE AND NICHOLS - ISLA DEL SOL GST AND PUMP STATION PROF SRVCS CONTRACT STAFF REPORT \(REV 0\).PDF](#)

- 11.U. Consider For Approval A Professional Services Contract With Pape-Dawson Engineers (Pape-Dawson) To Conduct The Engineering Design Of The Karankawa Beach & Gulf Palms Drainage Improvement Project For The City Of Galveston In The Amount Of \$969,555.00; Authorizing The City Manager To Execute All Necessary Documents Upon Final Approval By The City Attorney. (R Winiecke)

Documents:

[PAPE DAWSON - KARANKAWA BEACH DRAINAGE IMPROVEMENTS PROF SRVCS CONTRACT STAFF REPORT \(REV 0\).PDF](#)

- 11.V. Consider For Approval A Professional Services Contract With Arceneaux Wilson & Cole, LLC. (AWC) To Conduct The Engineering Design Of The Seawolf Park Wastewater Treatment Plant (WWTP) Project For The City Of Galveston In The Amount Of \$199,615.00; Authorizing The City Manager To Execute All Necessary Documents Upon Final Approval By The City Attorney. (R Winiecke)

Documents:

[AWC - SEAWOLF PARK WWTP PROF SRVCS CONTRACT STAFF REPORT \(REV 0\).PDF](#)

- 11.W. Consider For Approval The Repair Of The Existing Electrical Service That Provides Power To The Solid Waste Transfer Station Processing Building Utilizing Our Current Contract Number, COG-CON -22-857 With Crescent Electric. This Work Includes Bringing The Existing Services Up To Current CenterPoint And NEC Standards. (D Bender)

Documents:

[STAFF REPORT - CRESCENT ELECTRIC.PDF](#)

- 11.X. Consider For Approval The Acceptance Of The BuyBoard Contract #757-24 From Foster Fence, For Labor And Materials For The Restoration Of The Fence At Lift Station 38 In The Amount Of \$17,596.00. Authorizing The City Manager To Execute All Necessary Documents Upon Final Approval By The City Attorney. (T Arnold)

Documents:

[LIFT STATION 38 FENCE STAFF REPORT.PDF](#)

- 11.Y. Consider For Approval Awarding A 3-Year Contract For The Services Of Conducting Laboratory Sampling For The Water Supply And Wastewater Treatment Divisions (Bid 25-05) To Eastex Environmental Laboratory, Inc., In The Amount Of \$106,846.00. Authorizing The City Manager To Execute All Necessary Documents Upon Final Approval By The City Attorney. (T Arnold)

Documents:

[STAFF REPORT - LABORATORY WATER QUALITY SAMPLING CONTRACT - BID 25-05.PDF](#)

- 11.Z. Consider For Approval Minutes Of The January 9, 2025 Special Meeting Agenda. (J. Williams)

Documents:

[DRAFT MINUTES _01092025.PDF](#)

12. ACTION ITEMS

- 12.A. Consider For Approval A Resolution Of The City Council Of The City Of Galveston, Texas, Related To The Disposition Of L.A. Morgan School; Expressing Support For The Galveston Independent School District Trustees To Consider Alternative Use Plans For The L.A. Morgan School Site, Which Could Include A National Juneteenth Museum, And/Or A Community Park; Providing For Findings Of Fact And Providing For An Effective Date. (Lewis/C. Brown)

Documents:

[MORGAN RESOLUTION FEBRUARY 25.DOCX](#)

- 12.B. Consider For Approval The Creation Of A Steering Committee Of Fourteen (14) Members; Charging The Committee To Review The City's Comprehensive Plan, To Provide Input And Feedback Of Long-Range Goals And Policies Affecting The City, And To Provide Recommendations As May Be Appropriate. (P. Milburn)

Documents:

[STF RPT - COMPREHENSIVE PLAN STEERING COMMITTEE AND RESOLUTION.PDF](#)

- 12.C. Receive And Accept The Report Of The City Auditor Related To The Conflict Of Interest Audit That Office Has Conducted On The Park Board.

- 12.C.1. Consider For Action Any Recommendation Of The Auditors Office That The Conflict Of Interest Audit Conducted By The City Auditors Office Of The Park Board Be Expanded In Any Way.

- 12.C.2. Consider For Action Any Procedural Changes As May Be Recommended In Or Inferred From The Conflict Of Interest Report Delivered By The City Auditor Office.

- 12.C.3. Consider For Action An Amendment To The City Auditor's Audit Plan To Include Audits Of The Park Board Staff's Use Of HOT Funds As May Be Recommended By The City Auditor.

- 12.D. Discuss And Consider Appointments To The Following City Boards, Commissions, And Committees:

1. Short Term Rental Ad Hoc Committee - District 1
2. Galveston Housing Finance Corporation/Galveston Property Finance Authority
3. Comprehensive Plan Steering Committee

13. ADJOURNMENT

I certify that the above Notice of Meeting was posted in a place convenient to the public in compliance with Chapter 551 of the Texas Government Code on February 21, 2025 at 12:40 P.M.

Janelle Williams

Janelle Williams, City Secretary

IN ACCORDANCE WITH THE PROVISIONS OF THE AMERICANS WITH DISABILITIES ACT (ADA), PERSONS IN NEED OF A SPECIAL ACCOMMODATION TO PARTICIPATE IN THIS PROCEEDING SHALL, WITHIN THREE (3) DAYS PRIOR TO ANY PROCEEDING, CONTACT THE CITY SECRETARY'S OFFICE, SUITE 201, 823 ROSENBERG, GALVESTON, TEXAS 77550 (409-797-3510).

One or more members of the City Council may attend the meeting by videoconference. A quorum of the members of the City Council will be physically present at the meeting location.

JOHN CORNYN
TEXAS

United States Senate

WASHINGTON, DC 20510-4305

January 20, 2025

Dear Fellow Texans:

Today we celebrate Martin Luther King Jr. Day and honor the remarkable legacy of this civil rights leader who led a life defined by courage and compassion.

As a father, husband, reverend, and pillar of his community, Dr. King inspired hope and sparked change by advocating for a just and unified America, and his example continues to guide us today.

Dr. King's mission to establish respect and equality for everyone, regardless of the color of their skin, serves as an important reminder that our words and actions have a tremendous impact on those around us.

Honoring Dr. King's vision is a practice we can each choose to walk in by extending grace and understanding to those who may hold a different opinion from us. I will continue to heed Dr. King's message as I serve more than 31 million Texans in the United States Senate.

I encourage all Texans to honor Dr. King's legacy today and every day by remembering his immeasurable contributions to our nation's progress toward equality and justice for all.

May God bless you all, and may He continue to bless the great State of Texas.

Sincerely,

A handwritten signature in blue ink that reads "John Cornyn". The signature is written in a cursive style with a large initial "J" and "C".

JOHN CORNYN
United States Senator

AO 440 (Rev. 06/12) Summons in a Civil Action

25-004

UNITED STATES DISTRICT COURT

for the
Southern District of Texas

AUDREY DICKSON-WALKER

Plaintiff(s)

v.

STONEY CLEMENT, and RAY NOLAN

Defendant(s)

Civil Action No. 3:24-cv-322



SUMMONS IN A CIVIL ACTION

To: (Defendant's name and address) Stoney Clement



A lawsuit has been filed against you.

Within 21 days after service of this summons on you (not counting the day you received it) — or 60 days if you are the United States or a United States agency, or an officer or employee of the United States described in Fed. R. Civ. P. 12 (a)(2) or (3) — you must serve on the plaintiff an answer to the attached complaint or a motion under Rule 12 of the Federal Rules of Civil Procedure. The answer or motion must be served on the plaintiff or plaintiff's attorney, whose name and address are:

James P. Roberts

Palmer Perlstein
15455 Dallas Parkway, Suite 540
Addison, Texas 75001

If you fail to respond, judgment by default will be entered against you for the relief demanded in the complaint. You also must file your answer or motion with the court.

Nathan Ochsner, Clerk of Court

Date: November 7, 2024



Nathan Ochsner

s/ V. Aranda
Signature of Clerk or Deputy Clerk

25-005

GRABLE
GRIMSHAW
PLLC

January 16, 2025

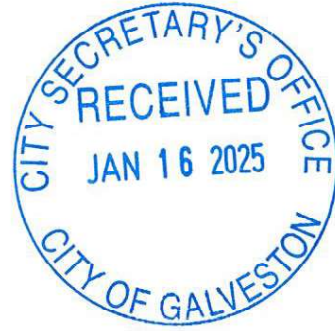

VIA EMAIL:

Craig Brown, Mayor
craigbrown@galvestontx.gov
Sharon B. Lewis, District 1
sharonlewis@galvestontx.gov
David Finklea, District 2
davidfinklea@galvestontx.gov
Bob Brown, District 3
bobbrown@galvestontx.gov
Donald Glywasky, City Attorney
Dglywasky@galvestontx.gov

Alex Porretto, District 4
alexporretto@galvestontx.gov
Beau Rawlins, District 5
beaurawlins@galvestontx.gov
Marie Robb, District 6
marierobb@galvestontx.gov
Doug Balli, Police Chief
Via Linda Strevell, Assistant to the Chief
lstrevell@galvestontx.gov

RE: Mr. Nicholas Gilmore: Settlement Demand and Preservation Letter

Dear Mayor Craig Brown, Chief of Police Doug Balli, and City Council:

We represent Mr. Nicholas Gilmore in his claims against the City of Galveston and specific members of the Galveston Police Department, particularly Lieutenant Joel Caldwell and Sergeant James Stewart.

This letter presents a good faith demand for settlement to resolve multiple constitutional violations Mr. Gilmore suffered. Mr. Gilmore demands \$25,000.00 (Twenty-Five Thousand Dollars and No Cents) to settle his claims.

This offer expires on January 24, 2025, at 5:00 PM CST, allowing for consideration at the regularly scheduled Galveston City Council meeting. We will be forced to file a lawsuit by March 15, 2025 to avoid statute of limitations concerns.

25-006



CITY OF GALVESTON
FIRST NOTICE OF CLAIM FORM

TO BE COMPLETED BY CLAIMANT:

NAME: Celeste Taylor-Velasco

ADDRESS City/State/Zip [REDACTED]

HOME PHONE [REDACTED] CELL/WORK [REDACTED]

EMAIL ADDRESS [REDACTED]

DATE OF LOSS 1/18/2025 TIME OF LOSS 3:15PM LOCATION 9 Mile Road - See photo of location

POLICE IN ATTENDANCE: YES NO POLICE CASE# N/A

WRITE DOWN THE REASON FOR YOUR CLAIM:

I am a Real Estate Agent, and I was on my way to show the home at 11818 Cindy Road, Galveston around 3:30PM.

We were driving down 9 Mile Road to get there, not realizing how far this pipe was sticking out of the ground (and I am assuming it was a metal pipe on the 18th from the damage that was done to the frame of my car).

The area was not marked, and was impossible to see the danger while driving up on it until I drove over it and the damage was done. Thankfully it missed my oil pan or my engine would have been completely ruined from what the car service said.

Due to the snow last week, I did not get this earlier, but was glad to see that when I went by to take pictures of the road today that the cones were out

ATTACH ANY ADDITIONAL INFORMATION/ RECEIPTS/ ETC. THAT MAY BE IMPORTANT TO YOUR CLAIM.

CLAIMANT SIGNATURE Celeste Taylor-Velasco DATE 1/27/2025
DocuSigned by: B585B3CCFB49450...

PLEASE RETURN TO: CITY OF GALVESTON
OFFICE OF CITY SECRETARY
P.O. BOX 779
GALVESTON, TEXAS 77553

25-007



CITY OF GALVESTON
FIRST NOTICE OF CLAIM FORM

TO BE COMPLETED BY CLAIMANT:

NAME: Eduardo Esquivel

ADDRESS City/State/Zip [REDACTED]

HOME PHONE [REDACTED] CELL/WORK [REDACTED]

EMAIL ADDRESS [REDACTED]

DATE OF LOSS 1-16-25 TIME OF LOSS Evening LOCATION 9 mile Rd

POLICE IN ATTENDANCE: YES NO POLICE CASE# _____

WRITE DOWN THE REASON FOR YOUR CLAIM:

Traveling N-on 9 mile in Evening. My son hit the water valve casing. City was working on it removed the barricades. Casing was left above ground level. The vehicle is a Camaro and sits low, casing caught bumper and his exhaust. Both of which are now damaged.

ATTACH ANY ADDITIONAL INFORMATION/ RECEIPTS/ ETC. THAT MAY BE IMPORTANT TO YOUR CLAIM.

CLAIMANT SIGNATURE Eduardo Esquivel DATE 1-27-25

PLEASE RETURN TO: CITY OF GALVESTON
OFFICE OF CITY SECRETARY
P.O. BOX 779
GALVESTON, TEXAS 77553

25-008



CITY OF GALVESTON
FIRST NOTICE OF CLAIM FORM

CITY CLAIM NUMBER

DATE RECEIVED BY THE
CITY SECRETARY'S OFFICE

TO BE COMPLETED BY CLAIMANT:

NAME: Marcella Gallo HOME ADDRESS [REDACTED]

HOME PHONE [REDACTED] CELL/WORK [REDACTED]

EMAIL ADDRESS [REDACTED]

DATE OF LOSS 2-30-25 TIME OF LOSS Don't know LOCATION _____

POLICE IN ATTENDANCE: YES NO POLICE CASE# _____

WRITE DOWN THE REASON FOR YOUR CLAIM:

I had my feet on the toll 7 foot
I was ride on the bus

ATTACH ANY ADDITIONAL INFORMATION/ RECEIPTS/ ETC. THAT MAY BE IMPORTANT TO YOUR CLAIM.

CLAIMANT SIGNATURE Marcella Gallo DATE 2/06/25

PLEASE RETURN TO:

CITY OF GALVESTON
OFFICE OF CITY SECRETARY
823 ROSENBERG
P.O. BOX 779
GALVESTON, TEXAS 77553

25-009



CITY OF GALVESTON
FIRST NOTICE OF CLAIM FORM

CITY CLAIM NUMBER

DATE RECEIVED BY THE
CITY SECRETARY'S OFFICE

TO BE COMPLETED BY CLAIMANT:

NAME: Eddie Calderas

HOME ADDRESS [REDACTED]

HOME PHONE _____

CELL/WORK [REDACTED]

EMAIL ADDRESS _____

DATE OF LOSS 2-3-25 TIME OF LOSS 10:34 AM LOCATION _____

POLICE IN ATTENDANCE: YES NO POLICE CASE# N/A

WRITE DOWN THE REASON FOR YOUR CLAIM:

Garbage truck license plate number 116 5946
backed into my Honda Civic 2009
1807 Conquistador Dr

ATTACH ANY ADDITIONAL INFORMATION/ RECEIPTS/ ETC. THAT MAY BE IMPORTANT TO YOUR CLAIM.

CLAIMANT SIGNATURE Eddie

DATE 02-10-25

PLEASE RETURN TO:

CITY OF GALVESTON
OFFICE OF CITY SECRETARY
823 ROSENBERG
P.O. BOX 779
GALVESTON, TEXAS 77553



STOY LAW GROUP

February 11, 2025

Via Email: citysec@galvestontx.com

Via Certified Mail #: 7022 1670 00001 5411 1707

#25-010



Attn: City Secretary
City of Galveston
823 Rosenberg St. Ste. 201
Galveston, Texas 77550

Re: Our Clients: Georgina "Gina" Hullum
Date of Injury: 2/3/2025
Business Name: Galveston Island Convention Center Parking Garage at The San Luis Resort
Incident Location: 5600 Seawall Blvd Galveston, Texas 77551

Dear Sir or Madam:

Please be advised that our law firm represents Gina Hullum, in claims for personal injuries arising out of an incident on February 3, 2025, at Galveston Island Convention Center Parking Garage at The San Luis Resort on 5600 Seawall Blvd Galveston, Texas 77551.

Please direct all correspondence and telephone calls regarding this matter to my office. Specifically, you are kindly instructed not to attempt to contact Gina Hullum or family.

We demand you immediately preserve all evidence of any type related to the above-reference claim. This request includes but is not limited to:

1. All photographs related to the above-referenced claim;
2. All audio and video records related to the above-referenced claim, including all audio and video records of my client while on your premises on the date of the subject incident;
3. Any and all incident reports, and any other compilation of information without limitation that relate to or memorialize the incident in the above-referenced claim;
4. All audio and video recordings of the incident in the above-referenced claim;
5. All audio and video recordings of the area where the incident in the above-reference claim occurred for the twenty-four hour period preceding the incident;
6. All audio and video recordings of the area where the accident in the above-reference claim occurred for the twenty-four hour period following the incident; and
7. Any other item of evidence related to the above-referenced claim and your defenses to it.



STOY LAW GROUP

8. Footage from all CCTV/security/surveillance cameras in the interior/exterior of the subject location from the date of the subject incident on which Plaintiff was depicted/captured;

Further, please accept this as my formal request to gain access to any documents, including, but not limited to, an incident report, a complete copy of the investigation file as well as employee statements collected by you for this incident for the purposes of an inspection including taking photographs and measurements. Please contact me upon receipt of this letter to discuss a convenient time for this prompt inspection. You are respectfully instructed not to conduct any maintenance, repairs, or make any modifications, alterations, or changes to the property damage prior to this inspection. You are also respectfully requested not to dispose of any remains of the property damage. Failure to comply with this request will be considered spoliation and destruction of evidence in this claim.

It is also my understanding that a video captured the incident involving my client. This is my formal request that you retain said video and forward a copy to me. Failure to comply with this request will be considered spoliation and destruction of evidence in this claim.

Now that you are on notice of my client's claims, you're under a legal duty to preserve all evidence related to this incident. If you fail to preserve the requested items, a Court may very well find that you have spoliated and destroyed evidence, which can have damaging legal consequences. Hence, if you have any questions about whether you need to preserve something, I would urge you to preserve it and to, at a minimum, contact me well in advance of any scheduled destruction or alteration so that we may discuss the issue.

Thank you for your kind and prompt attention in this regard.

Best Regards,

J. Robert Hudson, Jr.

JRH/ys

25-011



CITATION SMALL CLAIMS

NO. 25-NSC02-0023

Darrell Singleton
PLAINTIFF
VS.
GALVESTON POLICE DEPT.
601 54TH STREET
GALVESTON TX 77551

* IN THE JUSTICE COURT
*
*
* PRECINCT 2
*
*
* GALVESTON COUNTY, TEXAS

THE STATE OF TEXAS Galveston Police Dept., **DEFENDANT**, in the hereinafter-styled and numbered cause:

You have been sued. You may employ an attorney to help you in defending against this lawsuit. But you are not required to employ an attorney. You or your attorney must file an answer with the court. Your answer is due by the end of the 14th day after the day you were served with these papers. If the 14th day is a Saturday, Sunday, or legal holiday, your answer is due by the end of the first day following the 14th day that is not a Saturday, Sunday, or legal holiday. Do not ignore these papers. If you do not file an answer by the due date, a default judgment may be taken against you. For further information, consult Part V of the Texas Rules of Civil Procedure, which is available online and also at the court listed on this citation.

This citation is issued pursuant to a petition filed by the above-named plaintiff on the 11th day of February, 2025. The plaintiff's attorney's name and address are, , No Known Address or the plaintiff's address (if they have no attorney), is [REDACTED] Texas City TX 77591 Your answer may be filed with this court, located at 1922 Sealy, Galveston, TX 77550.

ISSUED on this the 12th day of February, 2025.



[Handwritten Signature]

JUSTICE OF THE PEACE
PRECINCT 2
GALVESTON COUNTY, TEXAS

Justice of the Peace, Pct. 2
1922 Sealy
Galveston, TX 77550
(409) 766-2250

2-13-25

Constable Derreck W. Rose
Galveston County PCT 3
600 59th St. 1st Floor
Galveston, TX 77551

[Handwritten Signature]

DARRELL SINGLETON
PLAINTIFF
VS.
GALVESTON POLICE DEPT.
DEFENDANT

*
*
*
*
*

IN THE JUSTICE COURT
JP2
GALVESTON COUNTY, TEXAS

RETURN ON CITATION

RULE 501.2(b). METHOD OF SERVICE. Citation must be served by: (1) delivering a copy of the citation with a copy of the petition attached to the defendant in person, after endorsing the date of delivery on the citation; or (2) mailing a copy of the citation with a copy of the petition attached to the defendant by registered or certified mail, restricted delivery, with return receipt or electronic return receipt requested.

RULE 501.2(e). ALTERNATE SERVICE OF CITATION. If the methods under (b) are insufficient to serve the defendant, the plaintiff, or the constable, sheriff, process server certified under order of the Supreme Court, or other person authorized to serve process, may make a request for alternative service. This request must include a sworn statement describing the methods attempted under (b) and station the defendant's usual place of business or residence, or other place where the defendant can probably be found.

Came to hand on the _____ day of _____, A.D., 20____, at _____, _____.M., and executed by me on the _____ day of _____, A.D., 20____ at _____, _____.M., *by delivering this citation to the within named defendant, _____ at _____ in _____ County, _____, by leaving a copy of this with _____ a person over sixteen years of age, at the usual place of abode defendant.

I actually and necessarily traveled _____ miles in the service of this citation.

Fees:
ServingCop....\$ _____
Mileage.....\$ _____
Total.....\$ _____

Constable _____
Precinct _____
_____ County, _____
Deputy Constable _____

Justice of the Peace, Pct. JP2
1922 Sealy
Galveston, TX 77550
(409) 766-2250

PETITION: SMALL CLAIMS CASE

CASE NO. 25-HS102-0023

In the Justice Court, Precinct 2, Galveston County, Texas

Received

PLAINTIFF Darrell Singleton

FEB 11 2025

VS.

DEFENDANT(S): Galveston Police Dept.

Justice of the Peace
Precinct 2
Galveston County Texas

Defendant(s) address: 601 54th Galveston, Tx. 77550

COMPLAINT: The basis for the claim which entitles the plaintiff to seek relief against the defendant is:

I was excessively beaten and assaulted by multiple police officers. They sprayed me with pepper spray as well in front of my children. I was kned in the growing and my eyes were burning for days. I was hurt for days. I was illegally detained and arrested. Falsely imprisoned and the video proved so.

RELIEF: Plaintiff seeks damages in the amount of \$ 10,000, and/or return of personal property as described as follows (be specific): N/A, which has a value of \$ 0.

Additionally, plaintiff seeks the following: N/A

SERVICE OF CITATION: Service is requested on defendants by personal service at home or work or by alternative service as allowed by the Texas Justice Court Rules of Court. Other addresses where the defendant(s) may be served are:

If you wish to give your consent for the answer and any other motions or pleadings to be sent to your email address, please check this box and provide your valid email address: [REDACTED]

Darrell Singleton
Petitioner's Printed Name

[Signature]
Signature of Plaintiff or Attorney

[REDACTED]
Address of Plaintiff's Attorney, if any, or Plaintiff if none

[REDACTED]
City State Zip

[REDACTED]
Phone & Fax No. of Plaintiff's Attorney, if any, or Plaintiff if none

DEFENDANT(S) INFORMATION (if known):

DATE OF BIRTH: _____

DEFENDANT'S PHONE NUMBER: _____

*LAST 3 NUMBERS OF DRIVER LICENSE: _____

*LAST 3 NUMBERS OF SOCIAL SECURITY: _____

ORDINANCE NO. 25 - ____

AN ORDINANCE OF THE CITY OF GALVESTON, TEXAS, CHANGING THE ZONING FROM RESIDENTIAL, SINGLE-FAMILY (R-1) ZONING DISTRICT AND RESIDENTIAL-SINGLE-FAMILY (R-1) ZONING DISTRICT TO RESTRICTED RESIDENTIAL, SINGLE FAMILY (R-0) ZONING DISTRICT ON VARIOUS PROPERTIES WHICH ADDRESSES ARE COMMONLY KNOWN AS **2712 – 2928 11 MILE ROAD**, AND AS PROVIDED IN THE ATTACHED MAP AND WHICH PROPERTIES ARE LEGALLY DESCRIBED AS: ABSTRACT 121 PAGE 48 LOTS 1 THROUGH 11 SEA BREEZE, AND ABSTRACT 121 PAGE 48 NORTH 75 FEET OF LOT 12 (12-1) SEA BREEZE, IN THE CITY AND COUNTY OF GALVESTON, TEXAS. PLANNING CASE NUMBER **25P-004**; MAKING VARIOUS FINDINGS AND PROVISIONS RELATED TO THE SUBJECT.

WHEREAS, the City has received a request to change the zoning on the subject properties from Residential, Single-Family (R-1) zoning district to Restricted Residential, Single-Family (R-0) zoning district. The various property addresses are commonly known as **2712 – 2928 11 Mile Road**. The properties are legally described as: Abstract 121 Page 48 Lots 1 Through 11 Sea Breeze, and Abstract 121 Page 48 North 75 Feet of Lot 12 (12-1) Sea Breeze, in the City and County of Galveston, Texas; and,

WHEREAS, the request is to designate all properties in the subject area as a Restricted Residential, Single-Family (R-0) zoning district. This neighborhood is currently zoned Residential, Single-Family (R-1). The primary distinction between the R-1 and R-0 zoning district is the ability of property owners to legally use their homes as short term rental dwellings. Short term rentals are not permitted in the R-0 zoning district; and,

WHEREAS, the approval of this request will result in the prohibition of short term rental uses within the subject neighborhood; and,

WHEREAS, as set forth in the staff report, attached and fully incorporated herein as **Exhibit 1**, and in accordance with the criteria to establish a Restricted Residential, Single-Family (R-0) zoning district of the City of Galveston’s Land Development Regulations, Staff finds that the rezoning request meets the criteria required, including; but not limited to, the following:

1. 75 percent of the dwellings in the proposed zoning area are single-family owner occupied structures;
2. 75 percent of the property owners initiated a petition to rezone to R-0. The petition was initiated by 83 percent of property owners;
3. Commercial uses and short term rentals are prohibited. (No commercial uses currently in operation. Existing short term rental uses will not be affected by this request);
4. The petition identified the streets, street blocks, and boundary subject to the rezoning;

5. The neighborhood is similar in design and character;
6. Dangerous and dilapidated structures as defined in the Municipal Code are not currently present within the proposed boundary of the R-0 district; and,

WHEREAS, Staff finds that the rezoning request meets the demonstrative criteria required for approval, per Division 13.601 (C), of the Land Development Regulations based on the following findings:

- a. The proposed zoning is preferable to the existing zoning in terms of its likelihood of advancing the goals, objective and policies of the City of Galveston 2011 Comprehensive Plan and other adopted plans;
- b. The proposed zoning is consistent with the future land use map prepared by staff and accompanying the staff report for this case;
- c. The proposed change is consistent with the implementation of existing or planned streets, water, wastewater, other utilities and delivery of public services to the area in which the proposed rezoning is located;
- d. The range of uses and character of development allowed by the proposed zone will be compatible with the properties in the immediate vicinity of the parcel proposed for rezoning and the parcel has sufficient dimensions to accommodate reasonable development that complies with the requirements or the Land Development Regulations including parking and buffering requirements;
- e. The pace of development and/or amount of vacant land currently zoned for comparable development in the vicinity suggests a need for the proposed rezoning in order to ensure an appropriate inventory of land to maintain a competitive land market that promotes economic development; and,

WHEREAS, the request is consistent with the criteria to establish a Restricted Residential, Single-Family (R-0) zoning district, and the neighborhood will remain single-family in orientation, hence not creating any adverse effect or incompatibility issues within the subject area and existing surrounding uses. Staff recommends approval of the proposed change of zoning in order to designate the subject neighborhood as a Restricted Residential, Single-Family (R-0) zoning district; and,

WHEREAS, at its regular meeting of February 4, 2025, the Planning Commission voted to recommend approval of the zoning change request; and,

WHEREAS, after conducting a public hearing, the City Council of the City of Galveston, Texas, finds that the rezoning request meets the demonstrative criteria required for approval, per Division 13.601 (C), of the Land Development Regulations and deems it in the public interest to grant applicant's request for a change of zoning from Residential, Single-Family (R-1) Zoning District to Restricted Residential, Single-Family (R-0), Zoning District.

NOW, THEREFORE, BE IT ORDAINED BY THE CITY COUNCIL OF THE CITY OF GALVESTON, TEXAS:

SECTION 1. The findings and recitations set out in the preamble to this Ordinance are found to be true and correct and they are adopted by the City Council and made a part hereof for all purposes.

SECTION 2. The zoning classification is hereby changed from Residential, Single-Family (R-1) Zoning District to Restricted Residential, Single-Family (R-0), Zoning District. The various property addresses are commonly known known as **2712 – 2928 11 Mile Road**. The properties are legally described as Abstract 121 Page 48 Lots 1 Through 11 Sea Breeze, and Abstract 121 Page 48 North 75 Feet of Lot 12 (12-1) Sea Breeze, in the City and County of Galveston, and as more detailed in the Staff report attached herein as Exhibit 1.

SECTION 3. As a result of the zoning classification change, there are no known or enumerated properties that have legally non-conforming uses or that may continue to operate the property as a short term rental.

SECTION 4. It is declared to be the intention of the City Council that the sections, paragraphs, sentences, clauses, and phrases of this Ordinance are severable. If any phrase, clause, sentence, paragraph or section of this Ordinance should be declared invalid by a final judgment or decree of any court of competent jurisdiction, such invalidity shall not affect any of the remaining phrases, clauses, sentences, paragraphs, and sections of this Ordinance.

SECTION 5. All Ordinances or parts thereof in conflict herewith are repealed to the extent of such conflict only.

SECTION 6. In accordance with the provisions of Sections 12 and 13 of Article II of the City Charter this Ordinance has been publicly available in the office of the City Secretary for not less than 72 hours prior to its adoption; that this Ordinance may be read and published by descriptive caption only.

SECTION 7. This Ordinance shall be and become effective from and after its adoption and publication in accordance with the provisions of the Charter of the City of Galveston.

APPROVED AS TO FORM:

DONNA M. FAIRWEATHER
SR. ASSISTANT CITY ATTORNEY

I, Janelle Williams, Secretary of the City Council of the City of Galveston, do hereby certify that the foregoing is a true and correct copy of an Ordinance adopted by the City Council of the City of Galveston at its Regular meeting held on February 27, 2025, as the same appears in records of this office.

IN TESTIMONY WHEREOF, I subscribe my name hereto officially under the corporate seal of the City of Galveston this _____ day of _____, 2025.

Secretary for the City Council
of the City of Galveston



25P-004

STAFF REPORT

ADDRESSES:

2712-2928 11 Mile Road

LEGAL DESCRIPTION:

Abstract 121 Page 48 Lots 1 through 11 Sea Breeze and Abstract 121 Page 48 North 75 Feet of Lot 12 (12-1) Sea Breeze, in the City and County of Galveston, Texas.

APPLICANT/REPRESENTATIVE:

Development Services Department

PROPERTY OWNER:

Various

ZONING DISTRICT:

Residential, Single-Family (R-1)

REQUEST:

Request for a Change of Zoning in order to designate the area as a Restricted Residential, Single-Family (R-0) zoning district.

STAFF RECOMMENDATION:

Approval

EXHIBITS:

- A – Zoning/Boundary Map
- B – Land Use Comparison

STAFF:

Pete Milburn, Sr. Project Manager
 409-797-3672
 Pmilburn@galvestontx.gov

Public Notice and Comment:

Sent	Returned	In Favor	Opposed	No Comment
19	4	4	0	0

Per Section 13.808 of the Land Development Regulations and state law, written public notice of this request is required. Public notices are sent to all property owners within 200 feet of the subject site and are sent to the address on file with the Galveston Central Appraisal District.

City Department Notification Responses:

- Airport: No Objection
- Building Division: No Objection
- Coastal Resources: No Objection
- Fire Marshal: No Objection
- Fire Chief: No Objection
- Police Chief: No Objection
- Public Works: No Objection

Private Utilities Notification Responses:

- AT&T: No Objection
- Comcast: No Objection
- CenterPoint Energy: No Objection
- Texas Gas Service: No Objection



Executive Summary

The request is to designate the properties shown on the above map as a Restricted Residential, Single-Family (R-0) zoning district. The area is currently zoned Residential,

Single-Family (R-1). The primary distinction between the R-0 and R-1 zoning districts is the ability of property owners to legally use their homes as a short term rental dwelling. Short term rentals are not allowed in the R-0 zoning district.

Interpretation of Use Classification

As changes of zoning are of a permanent nature, regardless of the present proposed land use for the properties, which will remain single-family residential, the Planning Commission and City Council must consider all potential future land uses that will become permitted uses should the request for a change of zoning be approved. Please see Exhibit 'B' for a comparison list of the permitted uses in the Residential, Single Family (R-1) and Restricted Residential, Single-Family (R-0) zoning districts.

Compatibility with Surrounding Land Use and Zoning

No proposed change to present land use, the neighborhood will remain single-family in character. Therefore, this request does not affect compatibility with surrounding uses and zoning.

Zoning and Land Use

Location	Zoning	Land Use
Subject Site	Residential, Single-Family (R-1)	Residential
North	Residential, Single-Family (R-1)	Residential
South	Residential, Single-Family (R-1)	Water
East	Residential, Single-Family (R-1)	Wetlands
West	Water (R-1)	Water

Criteria to Establish R-0 Zoning District

Per the City of Galveston’s Land Development Regulations, the following criteria must be met to establish a Restricted Residential, Single-Family (R-0) zoning district:

Criteria	Proposed District
75 percent of the dwellings in the proposed zoning area must be single-family owner occupied structures.	Per available records, at least 75 percent of the dwellings are owner occupied.
75 percent of the property owners shall initiate a petition to rezone to R-0.	Petition initiated by 83 percent of property owners.
Commercial uses and short term rentals prohibited.	No commercial uses currently in operation. Existing short term rental uses will not be affected by this request.
The petition shall identify the streets, street blocks, and boundary subject to the rezoning.	The petition enumerates all addresses of properties subject to rezoning within the area boundary.
The neighborhood must be similar in design and character.	The neighborhood is very similar in design and character. Lot layouts, setbacks, street layout, and type of construction are consistent throughout the neighborhood.

Dangerous and dilapidated structures as defined in the Municipal Code must not be present within the proposed boundary of the R-0 district.	No dangerous and dilapidate structures currently exist in the area.
---	---

Criteria for Approval

According to Division 13.601 (C) of the Land Development Regulations, the Planning Commission may recommend approval, and City Council may grant the approval of a rezoning request if it is demonstrated that:

1. The proposed zoning is preferable to the existing zoning in terms of its likelihood of advancing the goals, objectives and policies of the City's 2011 Comprehensive Plan and other adopted neighborhood plan, special area plan, redevelopment plan, or other plan applicable to the area;
2. The proposed zoning is consistent with the future land use map of the 2011 Comprehensive Plan (a future land use map amendment may be processed concurrently with the rezoning);
3. The proposed change is consistent with the implementation of existing or pending plans for providing streets, water and wastewater, other utilities and the delivery of public services to the area in which the parcel proposed for rezoning is located;
4. The range of uses and the character of development that is allowed by the proposed zone will be compatible with the properties in the immediate vicinity of the parcel proposed for rezoning, and the parcel proposed for rezoning has sufficient dimensions to accommodate reasonable development that complies with the requirements of these Land Development Regulations, including parking and buffering requirements; and
5. The pace of development and/or the amount of vacant land currently zoned for comparable development in the vicinity suggests a need for the proposed rezoning in order to ensure an appropriate inventory of land to maintain a competitive land market that promotes economic development.

Conformance

Staff finds this request to be consistent with the criteria to establish a Restricted Residential, Single-Family (R-0) zoning district, and the change of zoning approval criteria as prescribed in Section 13.601 (C) of the Land Development Regulations. The neighborhood will remain single-family in orientation, hence not creating any adverse effect or incompatibility issues within the area and existing surrounding uses.

Staff Recommendation

Staff recommends approval of the proposed change of zoning in order to the designate area as a Restricted Residential, Single-Family (R-0) zoning district.

Other Reviews

The Planning Commission reviewed this request at the February 4, 2025 meeting and voted to recommend approval.

Respectfully Submitted,

Pete Milburn

Pete Milburn, Sr. Project Manager

2-19-2025

Date

Cathy

Catherine Gorman, AICP
Assistant Director/HPO

02-19-2025

Date

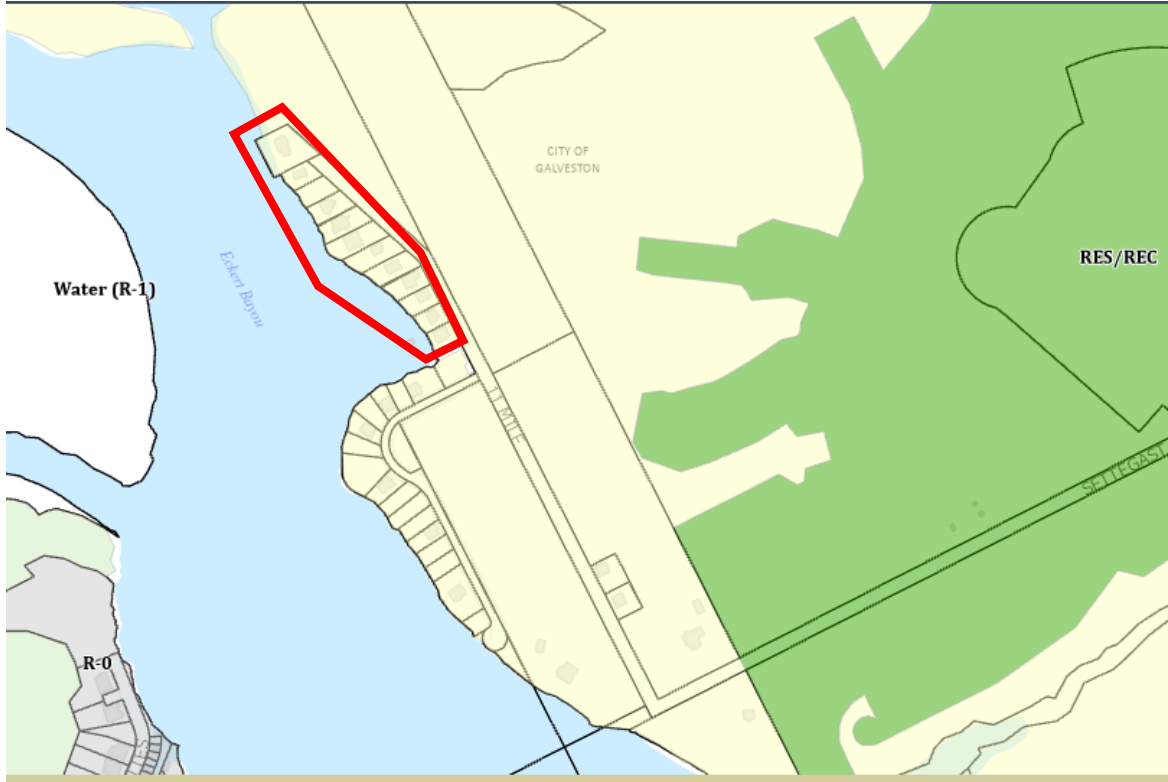

Exhibit B

Agricultural Land Use	R-0	R-1
Agricultural Support	-	-
Agriculture/Urban Farming	-	L
Commercial Stable	-	-
Residential Stable	-	-
Veterinarian, Large Animal	-	-
Residential Land Uses	R-0	R-1
Accessory Dwelling Unit	L	L
Bed and Breakfast	-	-
Boarding House, Dormitory, Fraternity or Sorority	-	-
Child Care Facility, Residential (Day Care)	-	-
Community Garden	-	L
Cottage Food Production	P	P
Home Based Business	-	-
Home Based Occupation	L	P
Hospital House Establishment	-	-
Live-Work Unit	-	-
Condominium	-	-
Duplex	-	-
Multi-Family Residential	-	-
Residential Land Uses	R-0	R-1
Personal Care Homes (DADS)	P	P
Short Term Rental Residential Dwelling	-	P
Single-Family Detached	P	P

Exhibit B

Townhouse	-	-
Commercial Land Uses	R-0	R-1
Adult Day Care	-	-
Adult Use (SOB)	-	-
Alcoholic Beverage Sales, Liquor Store or Package	-	-
Arena / Stadium	-	-
Auto Service/Fueling or Charging Station	-	-
Bar	-	-
Boat Repair Facility	-	-
Boat Sales or Rental	-	-
Child Care Facility, Day Care (Commercial)	-	-
Cleaning / laundry pick-up station	-	-
Cleaning / laundry-mat self service	-	-
College / University / Vo-Tech	-	-
Commercial Land Uses	R-0	R-1
Commercial Amusement, Indoor	-	-
Commercial Amusement, Outdoor	-	-
Commercial Lodging (Hotel)	-	-
Commercial Warehousing and Logistics	-	-
Correctional or Rehabilitation Facility	-	-
Credit Access Business	-	-
Family Care Facility	-	-

Exhibit B

Flea Market	-	-
Golf Carts, Sales and Service	-	-
Gun Shop	-	-
Heavy Vehicle, Manufactured Home, Watercraft or Aircraft Sales or Rental	-	-
Homeless Shelter	-	-
Hospital	-	-
Kennel	-	-
Library	-	-
Medical Office / Clinic / Lab	-	-
Fine Arts Instruction	L	L
Nursery or Greenhouse, Retail	-	-
Nursing / Convalescent Home	-	-
Office	-	-
Outdoor Storage	-	-
Commercial Land Uses	R-0	R-1
Parking Lot, Commercial Surface Parking Area	-	-
Parking Structure or Lot Incidental to Main Use	-	-
Parking Structure – Mixed Use	-	-
Passenger Motor Vehicle Sales or Rental	-	-
Pawn Shop	-	-
Personal Fitness	-	-
Pet Grooming Services	-	-
Place of Private Assembly	-	-

Exhibit B

Place of Public Assembly	-	-
Private Club	-	-
Professional Services, Instruction/Counseling	-	-
Public Safety Facility	-	-
Recreation Indoor	-	L
Recreation Outdoor	-	L
Recycling Center	-	-
Restaurant, Drive-In / Through	-	-
Restaurant, No Drive-In / Through	-	-
Retail - Big Box	-	-
Retail - Commercial	-	-
RV Park	-	-
School: Private	-	-
Self Storage	-	-
Commercial Land Uses	R-0	R-1
Short Term Rental Residential Dwelling	-	P
Small Scale Food And Beverage Production	-	-
Substance Abuse Facility	-	-
Vehicle Wash	-	-
Vending Kiosk/ATM	-	-
Veterinarian, Small Animal	-	-
Wholesale	-	-
Industrial Land Use	R-0	R-1
Automotive Wrecking and Salvage Yard; Junkyard; Recycling Business	-	-
Excavation	L	L

Exhibit B

Heavy Industry	-	-
Light Industry	-	-
Mining / Extraction	-	-
Research and Testing Laboratory	-	-
Parking and/or Multimodal Transportation Facility	-	-
Power Generation	-	-
Public Utility Facility, Neighborhood	-	-
Industrial Land Use	R-0	R-1
Towing Service Facility	-	-
Uses involving Radioactive Material, not including uses related to diagnosis and treatment of illness; and, construction applications; and, academia and scientific research	-	-
Public/Private Land Uses	R-0	R-1
Airport	-	-
Cemetery	-	-
Heliport	-	-
Helistop	-	-
Marina	-	-
Public Utility Plant	-	-
Rail Yard	-	-
Port and Harbor Facilities	-	-
Wireless Telecommunication Facility	-	-

ORDINANCE NO. 25 - ____

AN ORDINANCE OF THE CITY OF GALVESTON, TEXAS, CREATING A PLANNED UNIT DEVELOPMENT (PUD) OVERLAY ZONING DISTRICT IN A COMMERCIAL (C) ZONING DISTRICT TO DEVELOP AN AUTO FUELING STATION LAND USE ON PROPERTY COMMONLY KNOWN AS **13722-14000 SAN LUIS PASS ROAD / FM 3005**, AND WHICH IS LEGALLY DESCRIBED AS PART OF LOTS 32 AND 45 (45-5), AND ADJACENT ABANDONED STREET, TRIMBLE AND LINDSEY SURVEY, SECTION 3, IN THE CITY AND COUNTY OF GALVESTON, TEXAS; PLANNING CASE NUMBER **25P-001**; MAKING VARIOUS FINDINGS AND PROVISIONS RELATED TO THE SUBJECT; AND PROVIDING FOR AN EFFECTIVE DATE.

WHEREAS, Article 4 of the 2015 Galveston Land Development Regulations (LDR) allows for the creation of a Planned Unit Development (PUD) Overlay Zoning District; and,

WHEREAS, the Applicant is Nasser Zia, and the owner is Beach Three LLC. Series 5, and they are requesting to establish a Planned Unit Development (PUD) Overlay Zoning District in a Commercial (C) base zoning district; and,

WHEREAS, the applicant intends to establish an “Auto Fueling Station” land use in the Commercial (C) base zoning district. The site previously operated as an “Auto Fueling Station” however the gasoline sales ceased in 2020. As the Auto Fueling Station Use has lapsed for more than 365 days, the current new regulations for such use must be met; and,

WHEREAS, the proposed land use of “Auto Fueling Station”, is a Limited Use in the Commercial (C) zoning district so long as the associated Limited Use Standards are met; and,

WHEREAS, as further detailed in the Staff Report, attached and incorporated herein as **Attachment 1** (including Exhibits), the subject site consists of a lot located at the northwest corner of the intersection of San Luis Pass Road/FM 3005 and Buccaneer Blvd. The lot has an area of 2.21 acres. The site consists of a commercial center with several businesses including a real estate office, restaurant, seafood market, liquor store, and convenience store; and,

WHEREAS, at its meeting of February 4, 2025, the Planning Commission voted to recommend approval of the request with the modification of staff recommended conditions, to exclude the right of way screening, per section 9.301(B), of the Land Development Regulations; and,

WHEREAS, Staff finds that the proposed land use is generally compatible with the base zone and surrounding zoning and land uses. While the land use of “Auto Fueling Station” carries restrictions on proximity to residential zoning districts, the residential zoning district that is adjacent is currently undeveloped. The site is located at a commercial node which is intended to serve the needs of West End residents and visitors. The site does not conform to the current landscaping screening requirements in the Land Development Regulations. In order to buffer the “Auto Fueling Station” from any potential residential development on the adjacent residential

zoning and the traveling public, Staff recommends that right-of-way screening and visual screening per sections 9.301(B) and 9.301(D) be installed; and,

WHEREAS, Staff recommends approval of the request with conditions as provided in **SECTION 3 below**; and,

WHEREAS, after notice and conduct of a public hearing, the City Council of the City of Galveston, Texas, deems it in the public interest to grant Applicant’s request for a Planned Unit Development (PUD) Overlay Zoning District in a Commercial (C) base zoning district on property commonly known as 13722-14000 San Luis Pass Road / FM 3005, in the City and County of Galveston, Texas, subject to the conditions set forth in **SECTION 3** below.

NOW, THEREFORE, BE IT ORDAINED BY THE CITY COUNCIL OF THE CITY OF GALVESTON, TEXAS:

SECTION 1. The findings and recitations set out in the preamble to this Ordinance are found to be true and correct, and they are adopted by the City Council and made a part hereof for all purposes.

SECTION 2. Subject to certain conditions set forth in **SECTION 3** below, the Applicant is hereby granted a Planned Unit Development (PUD) Overlay Zoning District in a Commercial (C) base zoning district on property commonly known as 13722-14000 San Luis Pass Road / FM 3005, and which is legally described as Part of Lots 32 and 45 (45-5), and Adjacent Abandoned Street, Trimble and Lindsey Survey, Section 3, in the City and County of Galveston, Texas.

SECTION 3. The Planned Unit Development (PUD) Overlay Zoning District is subject to the following conditions:

Specific Conditions to 25P-001:

1. Granting of a PUD zoning district shall not relieve the developer from complying with all other applicable sections of the Land Development Regulations (LDR), and other Codes and Ordinances of the City of Galveston, unless such relief is specified in the approved PUD plan and PUD ordinance. Relief provided by this PUD plan includes:
 - a. To deviate from the minimum distance requirement from single-family residential district stipulated by Section 2.308 of the Land Development Regulations. The requirement is that an “Auto Fueling Station” land use shall be located at least 200 feet from residential use or residential zoning district boundary. The location of the proposed “Auto Fueling Station” is located adjacent to residential zoning district boundary.
2. The use shall conform to the attached PUD plan and other applicable ordinances;
3. A building permit(s) for the project shall be issued no later than 24 months from the date of City Council approval (February 27, 2025) and shall proceed in accordance with Ordinance No. 20-008, “Timeframe for Permits for Construction Activity”;

4. Prior to the issuance of a building permit, the developer shall install ~~right of way~~ and visual screening per sections ~~9.301(B) and~~ 9.301(D) of the Land Development Regulations;

Standard Conditions of a Planned Unit Development (PUD):

5. The applicant shall adhere to all comments/conditions received from City departments;
6. Any change or revisions to the adopted PUD Plan shall require an amendment to the PUD ordinance, which requires review by the Planning Commission and City Council. Minor additions and modifications to the approved PUD plan meeting the criteria set forth in Article 4, Section 4.102 (d)(3) of the Land Development Regulations (LDR) may be approved by the Development Services Department;
7. There shall be no nuisance created or cause any perceptible noise, odor, smoke, electrical interference, or vibrations that constitute a public or private nuisance to neighboring properties; and,
8. The applicant shall submit for approval all plans to the Development Services Department for compliance with all City codes.

SECTION 4. The zoning classification for this property shall be changed to Commercial (C)-PUD overlay and shall be designated as (C)-PUD on the zoning maps of the City of Galveston, subject to the conditions set forth in **SECTION 3** above.

SECTION 5. It is hereby declared to be the intention of the City Council that the sections, paragraphs, sentences, clauses, and phrases of this Ordinance are severable. If any phrase, clause, sentence, paragraph or section of this Ordinance should be declared invalid by a final judgment or decree of any court of competent jurisdiction, such invalidity shall not affect any of the remaining phrases, clauses, sentences, paragraphs, and sections of this Ordinance.

SECTION 6. All Ordinances or parts thereof in conflict herewith are repealed to the extent of such conflict only.

SECTION 7. In accordance with the provisions of Sections 12 and 13 of Article II of the City Charter this Ordinance has been publicly available in the office of the City Secretary for not less than 72 hours prior to its adoption; that this Ordinance may be read and published by descriptive caption only.

SECTION 8. This Ordinance shall be and become effective from and after its adoption and publication in accordance with the provisions of the Charter of the City of Galveston.

APPROVED AS TO FORM:

DONNA M. FAIRWEATHER
SR. ASSISTANT CITY ATTORNEY

I, Janelle Williams, Secretary of the City Council of the City of Galveston, do hereby certify that the foregoing is a true and correct copy of an Ordinance adopted by the City Council of the City of Galveston at its Regular Meeting held on February 27, 2025, as the same appears in records of this office.

IN TESTIMONY WHEREOF, I subscribe my name hereto officially under the corporate seal of the City of Galveston this _____ day of _____, 2025.

Secretary for the City Council
of the City of Galveston



25P-001

STAFF REPORT

ADDRESS:

13722-14000 San Luis Pass Road/FM 3005

LEGAL DESCRIPTION:

Property is legally described as Part of Lots 32 and 45 (45-5), and Adjacent Abandoned Street, Trimble and Lindsey Survey, Section 3, in the City and County of Galveston, Texas.

APPLICANT/REPRESENTATIVE:

Nasser Zia

PROPERTY OWNER:

Beach Three LLC Series 5

ZONING:

Commercial (C)

REQUEST:

Planned Unit Development (PUD)

APPLICABLE LAND USE REGULATIONS:

Article 4 of the Land Development Regulations

STAFF RECOMMENDATION:

Approval with Conditions

EXHIBIT:

- A – Applicant’s Submittal
- B – Zoning Map

STAFF:

Catherine Gorman, AICP
 Assistant Director/HPO
 409-797-3665
 cgorman@galvestontx.gov

Public Notice and Comment:

Sent	Returned	In Favor	Opposed	No Comment
5	0	0	0	0

Per Section 13.808 of the Land Development Regulations and state law, written public notice of this request is required. Public notices are sent to all property owners within 200 feet of the subject site and are sent to the address on file with the Galveston Central Appraisal District.

City Department Notification Responses:

- Airport: No Objection
- Building Division: No Objection
- Coastal Resources: No Objection
- Fire Marshal: No Objection
- Fire Chief: No Objection
- Police Chief: No Objection
- Public Works: No Objection

Private Utilities Notification Responses:

- AT&T: No Objection
- Comcast: No Objection
- CenterPoint Energy: No Objection
- Texas Gas Service: No Objection



Executive Summary

This is a request for a Planned Unit Development (PUD) Overlay District to establish “Auto Fueling Station” land use in the Commercial (C) zoning district. The purpose of the PUD is:

- To deviate from the minimum distance requirement from single-family residential district stipulated by Section 2.308 of the Land Development Regulations. The requirement is that an “Auto Fueling Station” land use shall be located at least 200 feet from residential use or residential zoning district boundary. The location of the proposed “Auto Fueling Station” is located adjacent to residential zoning district boundary.

The site previously operated as an “Auto Fueling Station” however the gasoline sales ceased in 2020. Since the use has lapsed for more than 365 days, then the new regulations must be met.

Site Details

The subject site consists of a lot located at the northwest corner of the intersection of San Luis Pass Road/FM 3005 and Buccaneer Blvd. The lot has an area of 2.21 acres. The site consists of a commercial center with several businesses including a real estate office, restaurant, seafood market, liquor store, and convenience store.

Compatibility with Base and Surrounding Zoning and Land Uses

The subject site is zoned Commercial (C). The proposed land use is “Auto Fueling Station” which is a Limited Use in the Commercial (C) zoning district. Limited Uses are permitted provided the associated Limited Standards are met. The Limited Standards require that a “Auto Fueling Station” not be located within 200 feet of a residential zoning district boundary. There is residential zoning directly adjacent to the property to the north and west. That residential zoning district is Residential, Single-Family (R-1) and is currently vacant.

Commercial (C) zoning is found to the east and south of the subject property. The site is located at commercial node at the intersection of San Luis Pass Road/FM 3005 and Buccaneer Blvd. Other land uses at this intersection include office, fitness facility, liquor store, and bank.

Staff finds that the proposed land use is generally compatible with the base zone and surrounding zoning and land uses. While the land use of “Auto Fueling Station” carries restrictions on proximity to residential zoning districts, the residential zoning district that is adjacent is currently undeveloped. The site is located at a commercial node which is intended to serve the needs of West End residents and visitors.

The Planned Unit Development (PUD) is a floating zoning district intended to create a mixture of uses, density and infrastructure standards, allowing flexibility in the development standards for specific uses on a specific site.

Ability of the Property to be used under Current Zoning

The subject site is zoned Commercial (C). The Commercial (C) district is intended to accommodate a wide range of retail, service, and office uses while also providing for a variety of housing options. As noted above, the land use of “Auto Fueling Station” carries restrictions on proximity to residential zoning districts.

PUD Details /Development Plan

The purpose or intent of the PUD	<p>The purpose or intent of the PUD is:</p> <ul style="list-style-type: none"> To deviate from the minimum distance requirement from single-family residential district stipulated by Section 2.308 of the Land Development Regulations. The requirement is that an “Auto Fueling Station” land use shall be located at least 200 feet from residential use or residential zoning district boundary. The location of the proposed “Auto Fueling Station” is located adjacent to residential zoning district boundary.
PUD Land Uses	“Auto Fueling Station”. No prohibitions of other uses permitted in the Commercial (C) base zoning district.
Density	No change in density.
Building Height	Existing strip center. No additional building.
Building Setbacks	No changes to the setbacks
Limits of Construction	The construction is only to remove the underground tanks, install a new underground tank, and a 20’x76’ canopy.
Building Elevations	No change to the existing building and elevations.
Vehicular Parking	There will be no change to the existing parking area.
Pedestrian Access	There will be no change to the existing pedestrian access.
Streets and Circulation	There will be no change to the existing street and circulation.
Screening and Landscape	There will be no change to the existing screening and landscape.
Environmental Protection	There will be a plan for any runoff from site to storm drains.
Signage	There will be no change to existing signage.
Lighting	Per Article 7 of the Land Development Regulations.
Phasing or Scheduling	The project will be completed in one phase.
Unique characteristics or exceptional circumstances	The subject site previously operated as a “Auto Fueling Station” with operations ceasing in 2020.

Criteria for Approval

Per Section 13.601.C of the Land Development Regulations, the Planning Commission may recommend approval and City Council may grant the approval of a rezoning request if it is demonstrated that:

1. The proposed zoning is preferable to the existing zoning in terms of its likelihood of advancing the goals, objectives, and policies of the City of Galveston 2011 Comprehensive Plan and other adopted neighborhood plans, special area plans, redevelopment plans, or other plans applicable to the area;
2. The proposed zoning is consistent with the future land use map of the City of Galveston 2011 Comprehensive Plan (a future land use map amendment may be processed concurrently with the rezoning);
3. The proposed change is consistent with the implementation of existing or pending plans for providing streets, water and wastewater, other utilities, and the delivery of public services to the area in which the parcel proposed for rezoning is located;
4. The range of uses and the character of development that is allowed by the proposed zone will be compatible with the properties in the immediate vicinity of the parcel proposed for rezoning, and the parcel proposed for rezoning has sufficient dimensions to accommodate reasonable development that complies with the requirements of these Regulations including parking and buffering requirements;
5. The pace of development and/or the amount of vacant land currently zoned for comparable development in the vicinity suggests a need for the proposed rezoning in order to ensure an appropriate inventory of land to maintain a competitive land market that promotes economic development.

Other Reviews

The Planning Commission reviewed this request at the February 4, 2025 meeting. The Planning Commission voted to recommend approval with Staff's Recommendations and the following change:

- Modify condition number 4 to remove the requirement for right-of-screening: *Prior to the issuance of a building permit, the developer shall install ~~right-of-way and~~ visual screening per sections 9.301(B) and 9.301(D) of the Land Development Regulations*

The vote was unanimous.

Staff Recommendation

Staff finds that the proposed PUD request conforms to the criteria for approval. The uses and the character of development that is proposed are compatible with the properties in the immediate vicinity of the subject parcel. The site is located at a commercial node which is intended to serve the needs of West End residents and visitors. Other land uses at this intersection include office, fitness facility, liquor store, and bank. Prior to ceasing operations in 2020, the subject site long operated as an "Auto Fueling Station" with no history of nuisance complaints.

The site does not conform to the current landscaping screening requirements in the Land Development Regulations. In order to buffer the "Auto Fueling Station" from any potential residential development on the adjacent residential zoning and the traveling public, Staff recommends that right-of-way screening and visual screening per sections 9.301(B) and 9.301(D) be installed. The screening requires a four-foot wide planting strip consisting of shrubs, hedges, and trees. The right-of-way screening would be required between any parking or loading areas and any street rights-of-way abutting the site, including San Luis Pass Road/FM 3005 and Buccaneer Blvd. The visual screening shall be installed and maintained between the parking or loading areas and driveways, and the residential zoning district.

Staff recommends approval with the following conditions:

Specific Conditions;

1. Granting of a PUD zoning district shall not relieve the developer from complying with all other applicable sections of the Land Development Regulations (LDR), and other Codes and Ordinances of the City of Galveston, unless such relief is specified in the approved PUD plan and PUD ordinance. Relief provided by this PUD plan includes:
 - a. To deviate from the minimum distance requirement from single-family residential district stipulated by Section 2.308 of the Land Development Regulations. The requirement is that an "Auto Fueling Station" land use shall be located at least 200 feet from residential use or residential zoning district boundary. The location of the proposed "Auto Fueling Station" is located adjacent to residential zoning district boundary.
2. The use shall conform to the attached PUD plan and other applicable ordinances;
3. A building permit(s) for the project shall be issued no later than 24-months from the date of City Council approval and shall proceed in accordance with Ordinance 20-008, Timeframe for Permits for Construction Activity;
4. Prior to the issuance of a building permit, the developer shall install right-of-way and visual screening per sections 9.301(B) and 9.301(D) of the Land Development Regulations;

Standard Conditions of a Planned Unit Development (PUD):

5. The applicant shall adhere to all comments/conditions received from City departments;
6. Any change or revisions to the adopted PUD Plan shall require an amendment to the PUD ordinance, which requires review by the Planning Commission and City Council. Minor additions and modifications to the approved PUD plan meeting the criteria set forth in Article 4, Section 4.102 (d)(3) of the Land Development Regulations (LDR) may be approved by the Development Services Department;

7. There shall be no nuisance created or cause any perceptible noise, odor, smoke, electrical interference, or vibrations that constitute a public or private nuisance to neighboring properties; and,
8. The applicant shall submit for approval all plans to the Development Services Department for compliance with all City codes.

Respectfully Submitted,



Catherine Gorman, AICP, Assistant Director/HPO

02/06/2025
Date

D. Development Plan- Reponses

Development Plan requirement:

- a. The purpose and intent of the PUD
The purpose is to remove existing under storage tanks and install one new underground storage for selling car fuel at existing C-store.
The location used to be as Auto fueling Station. the store stopped selling fuel after Covid -19.
The original store owner could not continue due to lack of business and sold out the business. The new owner wants to upgrade the store and continue the business.
- b. PUD land uses:
There is an existing strip center over 10,000 sq. ft
It is also used as auto fueling station.
- c. Density:
No change to existing density
- d. Building height:
Existing strip center, no addition building
- e. Building setback:
There will no change to set back, survey included
- f. Limits of construction:
The construction only to remove underground tanks, install a new underground tank and a canopy 20'x76'
- g. Building elevation:
No change to the existing building and elevations
- h. Vehicular parking:
There will be no change to existing parking areas
- i. Pedestrian access:
There will be on change to existing pedestrian access
- j. Streets and circulation:
No change to existing street and circulation

K. screening and landscaping:

There will be no change to existing screening and landscaping

l. Environmental protection:

There will be a plan for any run off from site to storm drains.

m. Signage:

There will no change to existing signages

n. Lighting:

There will no change to existing lighting, only adding extra lighting for new canopy

o. Phasing or scheduling

There will time only for construction time, this will not block any public Road

2. The application shall specify the extent to which deviation from otherwise applicable code requirements is justified by unique characteristics of the site or other exception circumstance.

We are requesting only a variance to remove old tanks and install a new 20K underground storage tank and a canopy at this location. It is a land use variance.

We are not changing or modifying any part of the building or parking area or driveways.

3. This Section is not applicable for this project.

4. This section is not applicable for this project.



Hummels General Store
 13722 FM 3005 Rd.
 Galveston, TX
 77554

Water tank location
 size: 35'x10'
 20K gal.,
 comp. 4k,12k,4k

Location of:
 New canopy
 24'x76'-
 3 new columns
 3 new dispensers

Site Plan

Legend	
	Overhead Power
	Rope Rail
	Wood Fence
	Concrete
	Asphalt
	Water Meter
	Power Pole
	Down Guy
	Clean-out
	Light Pole
	Manhole
	Fire Hydrant
	Easement Line

Drafting: JA
 Parcel ID: 309610
 Surveyed for: Mike Al

NZ Construction Corp. 4450 S. Wayside Dr. Suite 101 Houston, TX 77087	Project: 13722 FM 3005 Rd. Galveston, TX	Draw By:	Date:
	Scale:	Project No: COM2023-00242	

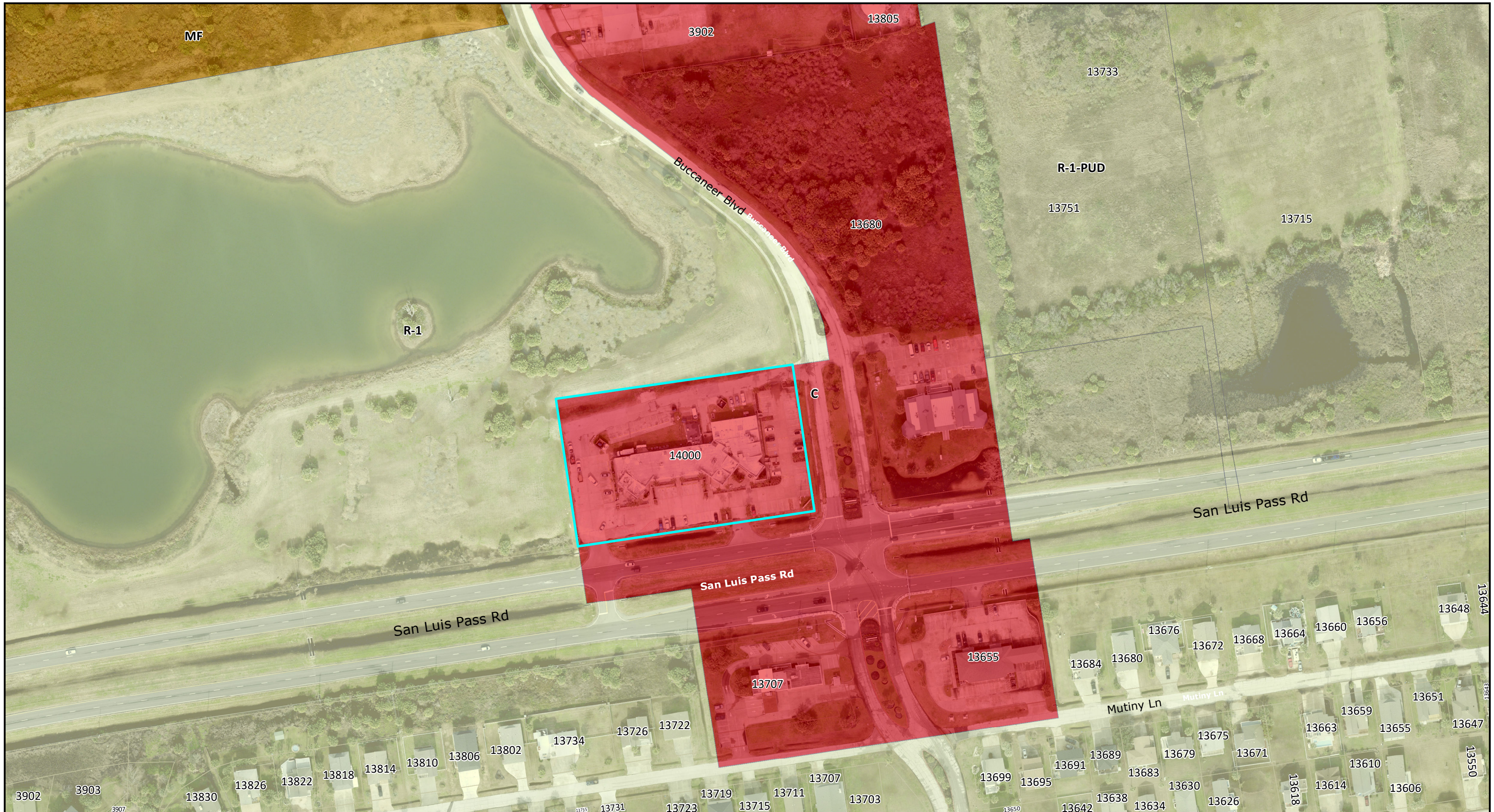

Planning and Development Division

Printed on: 01/28/2025
By: City of Galveston Development Services Department
Source Credits:
 City of Galveston, USGS, et al. - Basemap
 Galveston Central Appraisal District (GCAD) - Street Centerlines & Parcels
 GCAD & Pictometry - 2020 Aerial; City of Galveston - Landmarks, Historic Districts, Zoning Overlays, & Zoning Districts





 1 in = 148 feet

 0 140 Feet
Coordinate System: NAD 1983 StatePlane Texas South Central FIPS 4204 Feet
Units: Foot US

Image
 Commercial (C)
 Multifamily (MF)
 Residential, Single-Family (R-1)
 Parcels
RGB
 Red: Band_1
 Green: Band_2
 Blue: Band_3

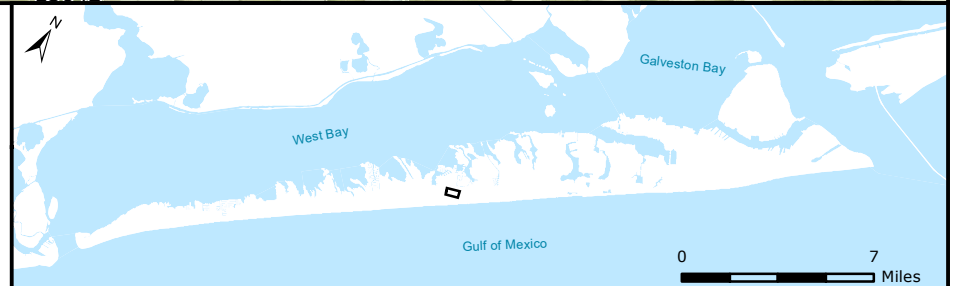

*This product is for informational purposes and may not have been prepared for or be suitable for legal, engineering, or surveying purposes. It does not represent an on-the-ground survey and represents only the approximate relative location of property boundaries. The data presented on these pages is not legally binding on the City of Galveston or any of its departments. These maps and the associated data are representations **only** and may contain errors in the databases. Therefore, the information presented on this map is for informational purposes only and should not be construed to be legally binding.*

ORDINANCE NO. 25 - ____

AN ORDINANCE OF THE CITY OF COUNCIL OF THE CITY OF GALVESTON, TEXAS, AMENDING THE DESIGNATED MEETING DAYS FOR THE YEAR 2025 OF JOINT MEETINGS WITH THE PARK BOARD OF TRUSTEES AND THE BOARD OF TRUSTEES OF THE GALVESTON WHARVES; RESERVING THE RIGHT OF COUNCIL TO SCHEDULE ADDITIONAL MEETINGS AS NEEDED; PROVIDING FOR FINDINGS OF FACT AND PROVIDING FOR AN EFFECTIVE DATE.

WHEREAS, City Charter Article II Section 10 provides that “the Council shall meet in regular session at the City Hall at least twice each month at such time as may be prescribed by Ordinance, unless otherwise ordered by the Council for reasons to be spread upon the Minutes”; and,

WHEREAS, City Code Article III Section 2-131., provides, “City council shall have the discretion to determine alternate dates, as well as, alternate times for meetings to begin. Each city council shall establish regular meeting times by a vote of the city council. Regular meeting times may be changed by a majority vote of the city council”; and,

WHEREAS, on December 12, 2024, per Ordinance No. 24- , City Council adopted its 2025 calendar of meeting dates, including joint meetings with the Park Board of Trustees and the Board of Trustees of the Galveston Wharves (the Boards). The City Council finds that it is in the best interest of the entities to amend the schedule of joint meetings with the Boards. As have occurred, the prior conjunction meetings with the Boards have led to several long hours of discussion. To then further proceed with a regular city council workshop and agenda, has then led to several more hours of meetings; and,

WHEREAS, separating the meetings with the Boards from regular city council meeting days will increase the efficacy and communication among the Boards and allow for more manageable use of time for the entities and for Staff that must be present for the meetings; and,

WHEREAS, aside from amending the schedule of conjunction meetings, the other City Council dates remain the same; and,

WHEREAS, the City Council deems it in the public interest to amend the schedule of joint meetings with the Boards for calendar year, 2025, as provided in SECTION 2 below.

NOW, THEREFORE, BE IT ORDAINED BY THE CITY COUNCIL OF THE CITY OF GALVESTON, TEXAS:

SECTION 1. That the findings and recitations set out in the preamble to this Ordinance are found to be true and correct and are hereby adopted by the City Council and made a part hereof for all purposes.

SECTION 2. That the City Council hereby designates the following dates on which to conduct its City Council meetings and Joint meetings with the Park Board of Trustees (Park Board) and the Board of Trustees of the Galveston Wharves (Wharves Board):

City Council Meeting

Joint Meeting

March 19 27, 2025

Joint Meeting with Park Board

April 24 30, 2025

Joint Meeting with Wharves Board

July 23, 24, 2025

Joint Meeting with Park Board

August 27, 2025

Joint Meeting with Wharves Board

October 22, 23, 2025

Joint Meeting with Wharves Board

November 13, 19, 2025

Joint Meeting with Park Board

SECTION 3. It is hereby declared to be the intention of the City Council that the sections, paragraphs, sentences, clauses, and phrases of this Ordinance are severable and, if any phrase, clause, sentence, paragraph or section of this Ordinance should be declared invalid by the final judgment or decree of any court of competent jurisdiction, such invalidity shall not affect any of the remaining phrases, clauses, sentences, paragraphs, and sections of this Ordinance, because the same would have been enacted by the City Council without the incorporation in this Ordinance of any such invalid phrase, clause, sentence, paragraph or section.

SECTION 4. All Ordinances or parts thereof in conflict herewith are repealed to the extent of such conflict only.

SECTION 5. In accordance with the provisions of Sections 12 and 13 of Article II of *The City Charter* this Ordinance has been publicly available in the office of the City Secretary for not less than 72 hours prior to its adoption; that this Ordinance may be read and published by descriptive caption only.

SECTION 6. This Ordinance shall be and become effective from and after its adoption and publication in accordance with the provisions of *The Charter of the City of Galveston, Texas*.

APPROVED AS TO FORM:

DONNA M. FAIRWEATHER
SR. ASSISTANT CITY ATTORNEY

I, Janelle Williams, Secretary of the City Council of the City of Galveston, do hereby certify that the foregoing is a true and correct copy of an Ordinance adopted by the City Council of the City of Galveston at its Regular Meeting held on February 27, 2025, as the same appears in records of this office.

IN TESTIMONY WHEREOF, I subscribe my name hereto officially under the corporate seal of the City of Galveston this ____ day of _____, 2025.

Secretary for the City Council
of the City of Galveston



Hotel Occupancy Tax Revenue City Auditor Executive Summary

BACKGROUND

The City of Galveston levies a Hotel Occupancy Tax (HOT) of nine percent (9%) on qualified room stays costing more than two dollars per night. Hotels are defined in Article III Section 33-86 of the City of Galveston Code of Ordinances as any building or buildings in which the public may, for consideration, obtain sleeping accommodations. The term shall include hotels, motels, tourist homes, houses or courts, lodging houses, inns, rooming houses, or other buildings where rooms are furnished for consideration but shall not be defined so as to include hospitals, sanitariums, or nursing homes.

The City of Galveston Code of Ordinances, Chapter 19, Article VI regulations for the use of residential dwelling units as short-term rental and ensure the collection and payment of hotel/motel occupancy taxes. A short-term rental (STR) is defined as the use of a residential dwelling unit or accessory building on a temporary or transient basis. A short-term rental shall include a residential dwelling unit or accessory building used as a short-term vacation rental for any period of less than thirty (30) consecutive days. The Park Board of Trustees is the administrative agency for the registration of short-term rentals and collection of rental registration fees. All owners/operators of a short-term rental must register the rental with the Park Board of Trustees.

The City of Galveston's Legal Department plays a supporting role in offering advice and filing City of Galveston claims against delinquent establishments.

The Hotel Occupancy Tax Revenue Recognition Audits were conducted as part of the Office of the City Auditor's Fiscal Year 2025 Strategic Audit Plan approved by the Mayor and City Council.

OBJECTIVES

The objective of the audits was to get Short-Terms Rentals and Hotels in compliance with applicable city and state laws.

SCOPE

The audit scope includes a random selection done by the Park Board.



Hotel Occupancy Tax Revenue City Auditor Executive Summary

METHODOLOGY

To accomplish our Audit Objectives, we performed the following steps:

- Reviewed applicable laws and regulations.
- Looked for advertisements on platforms.
- Sent out letters to homeowners.
- Reviewed financial documentation received from homeowners.
- Reconciled tax due.
- Worked with the Park Board accountant to register and pay back taxes due.

AUDIT RESULTS

The City Auditor's Office has identified forty-five (45) new short-term properties not registered or paying taxes to the Park Board. These forty-five (45) new short-term rentals are now registered with the Park Board, and a total estimated hot tax revenue, penalties, and interest in the amount of \$248,103 is to be collected.

The City Auditor's Office also identified six (6) hotels that owed additional taxes. For these six (6) hotels, a total estimated hot tax revenue, penalties, and interest in the amount of \$115,446 are to be collected.

This report accomplishes the full amount of \$363,549 in HOT Tax Audits required to be performed by the City Auditor's Office for the 2025 Fiscal Year City Auditor's Audit Plan.



Commercial Repair/Remodel Sales Tax Revenue City Auditor Executive Summary

February 1, 2025

BACKGROUND

Pursuant to the Texas Comptroller of Public Account's Publication 94-116 (06/2016), a service provider who repairs or remodels nonresidential real property should collect state sales tax plus any local sales tax on the total charge for the job. This figure includes all costs passed on to the customer except separately stated building permit fees paid on the customer's behalf. Local sales tax is to be collected for labor and materials based on the location of the job site.

A service provider who performs new construction jobs under separate contracts must issue its suppliers' resale certificates and then collect state sales tax plus any local sales tax on the charges for materials. The local sales tax on the separately stated charges for materials is based on the location of the job site. Also, the charges for the materials must be at least as much as the service provider paid for the materials.

OBJECTIVES

The objective of this summary is to determine if the appropriate state and local sales tax, if any, was collected and remitted on Commercial Repair/Remodel construction jobs.

SCOPE

The audit scope included documentation from January 1, 2022, through September 3, 2024, for Commercial Repair/Remodel permits. The geographical scope is the local taxing jurisdiction for the City of Galveston.

METHODOLOGY

To accomplish our Audit Objectives, we performed the following steps:

- Provided proof that the job was non-residential by documenting the description of the building permit and physical inspection.
- Provided proof that the job was a Repair/Remodel by documenting the building permit and project description.
- Provided proof that the job was not part of a Governmental Unit, Non-Profit Organization, or National Heritage Register through documentation of the Appraisal District certifications.
- Provided proof that the Property Owner (Customer) did not include the taxable construction costs as taxable purchases on its Sales and Use Tax Report by analyzing the applicable Confidentiality Report.



City of Galveston

City Auditor's Office
SAL2024-2025

Commercial Repair/Remodel Sales Tax Revenue City Auditor Executive Summary

SUMMARY RESULTS

During our audit, we identified 15 (fifteen) Construction Projects totaling \$17,859,638 for which sales tax was not paid to the City. The City Auditors Office uses a 60% Sales Tax was not Paid to 40% Sales Tax was Paid ratio to calculate the Sales Tax Due. The City receives 2% of the 8.25% total sales tax due. The City is owed \$214,316 in sales tax.

MEMORANDUM

To: Members of City Council

From: Donald S. Glywasky, City Attorney

Date: February 19, 2025

Re: Recommendation to retain the services of Pete Sapio of the Doyle Law firm for title work in association with the Pelican Island Bridge project

- 1) This is to request and recommend the City Attorney office retain the services of Pete Sapio of the Doyle Law firm to assist in preparation of various title documents for the Pelican Island Bridge. That firm is associated with Southland Title as well.
- 2) I have received the route map from TXDOT on the proposed route. The proposed route covers different property owners such as Lamson Nguyen, Texas A&M, Port of Houston and the Navigation District. I am unable to correlate the descriptions with a given property owner. While our GIS system allows us to get pretty close, close is not sufficient. When I write an instrument that a given entity is giving us a piece of realty, the City, and TXDOT, need to know that entity actually owns what they are conveying.
- 3) Mr. Sapio has years of this type of experience having first been associated with Chicago Title and now with the Doyle Law firm with its link to Southland.
- 4) I will have Mr. Sapio prepare the proper legal descriptions for me and also search of any heretofore unknown encroachments with the planned route area. Our focus will initially be on the Pelican Island and its immediate vicinity.
- 5) I do not know what the cost of this service will be, so I am estimating it at \$30,000. The reason I selected that figure is my office will request this funding be provided by IDC. As I am required to present a project budget for IDC, I am choosing that figure as a hedge. Given the replacement bridge is definitely an economic development project, I think it fall within IDC guidelines.
- 6) Therefore I request Council grant authority for the City Attorney to sign a letter of engagement with Pete Sapio of the Doyle law firm to provide these services with the dollar limit set out herein.

Hello. My name is Madonna Mamerow Victor. Today, I am here to introduce my artwork as well as myself and to discuss artwork painted on city roads that are funded by tax payers. Before I begin I believe from my understanding of the rules of the Art Commission that today's meeting is simply to determine "artistic merit".

I am not an artist by trade and have never really cared to submit artwork- it's not my thing. I was however, concerned enough by what I have seen from city council to apply today. I struggled immensely to understand the phrase "artistic merit" when few rules were given and most of the questions on the application are nullified by previous merited art. In fact I was quite surprised by the limited number of rules provided for this project especially since merit means I personally get to purchase the surface rights of a publically funded roadway to display my billboard AKA "artwork" as others have previously received the privilege to do. I just want equal opportunity to do the same.

Uncertainty regarding fair judgement was heavily weighed prior to my submission, given I am used to pages of specifications for anything I've ever built or proposed to the government. I also know that the topic I present comes with risk of being cancelled and not fully understood.

So, I contemplated how I judge artwork (and if I were on a committee what is the ethical responsibility one should have) and all I can determine is that an artist as of current times, to be successful all you need to do is simply provoke a strong emotional response from the individual consuming the art without any ethics considered. Why am I harping on this because I am a healthcare provider and I know that Emotions=actions and reactions from the public. In my profession I use the feelings wheel with many patients and I ask patients to write down the first 10 things they think about in the morning and then to describe how these thoughts make them feel. Most will use these words "cautious, scared, overwhelmed, anxious, nervous, restless, worried, apprehensive, insecure, vulnerable, panicked, edgy, uneasy, tense." All of which are generated from the root feeling of fear. This is overwhelmingly where our society is mentally. When people are in fear too long the emotion can progress to anger and the action of violence.

Art as of late has become emotional warfare. The process of creating this art generated emotions of uncertainty, a bit of fear, a bit of anger due to a lack of clarity and an ethics statement from the commission. The arts commission has a huge civic duty in protecting public health and welfare by directing our collective emotion in a healthy and positive manner. Artists already know that studies have shown that television and film have made people more unhappy since it's invention. Social media has even worse outcomes of depression, anxiety, eating disorders, and more have occurred from its consumption. Art ~~groups such as these~~ ^{groups} must begin to think logically about ethics and the standards you set for artistic experiences within our environment as a city.

Currently, anyone from outside the city can display artwork that residents must live with.

I had to ask myself what emotions do I want to provoke. I mostly wanted to provoke burden of ethics on the committee today. Artists seem to never think about their civic responsibility of directing emotion and some say it just pours out as what they are feeling they just go with it - which can be completely irresponsible in my opinion if the artwork is displayed in front of city hall-a neutral land. I want to emphasize to the committee today that you have the ability to heal and harm people with art and therefore the greatest civic responsibility not only to me to feel safe as a resident by talking to you today about ~~this~~ ^{my} perspective, but others as you determine what is fair and equal when deciding merit because

it will directly influence the sensory system of all humans and provoke emotion whether through sound, vision, taste, or touch and should move people toward positive actions.

If the committee has noticed, artists and the media are constantly hyper focused on directing our attention to sexual behaviors. The energy of creation. Most of it has provoked fear among each classification (the only unifying thing art has done is promote fear). Males are now scared to approach females for fear they will be accused of rape. Women are afraid of men rape them because of constant reports from Hollywood women describing their horrific experiences without regard that these reports inflict vicarious trauma onto all females to be fearful who may have never had such an experience while simultaneously these same women act out scenes of violence and rape through movie and television art for money. They are not my heroes. Female reproduction has been in the news a lot. Child sex trafficking. World leaders are constantly saying sorry for sexual dalliances. Harvey Weinstein, Jeffery Epstein, Sean Combs, Sean Carter. Clergy have committed child sexual abuse as well. LGBTQ individuals have also lived in fear over sex. Children now grow up discussing sexuality and gender extremely early in life and miss out on simple play time. Children grow up fast enough. There's a time for sex. It is so complex that even at 50 years old I'm still trying to understand all of it's many wonders.

The whole country has become hyper focused on vocabulary words when describing gender and many live in fear that a slip of the tongue may accidentally provoke someone to unfairly label you as phobic and hateful and will place livelihoods at risk. A discussion of this fear has not yet been handled by any leadership to heal such emotional trauma among all groups which has been inflicted unethically by those that call themselves "artists". Let me be clear, I understand this feeling today. Today, I am facing a reality that my art may very well effect my business, my home, and lay to waste my \$200K education if the wrong emotion is invoked. I would love if city hall had remained a neutral zone but that ship has sailed. ~~So we come to give me equal I want mine.~~

I am tired of Americans dividing themselves by different flags instead of embracing that we are all individuals living in this country because someone in the family said enough I want a better life for me and my family so I'm going to America and going to work for it (America derives from the root word Friend). Our slogan has been United we stand divided we fall. And our leadership is doing things in every group to divide us. So let me be clear I am not here to provoke hate or take away from anyone.

My art came from viewing the current street art and asking is this artwork is an attack on Christians and conservatives? Is it fair to all to paint on public streets in front of city hall permanently where various individuals with differing beliefs may gather or simply need to pay a water bill? Why was this allowed along the common parade route where various groups attend events including Mardi Gras celebrations, which is the 3rd largest Mardi Gras in the country to celebrate the beginning of the lenton season for Christians in preparation for Easter. This is the most important season for Christians as there is no Christianity without the death and resurrection of Jesus. My birthday also happens to be on Easter Sunday and it is celebrated twice a year by my family, thus it was important to a Catholic family and is why I have the name Madonna. It is a well known route put on by Tillman Fertita. It brings in tons of money to our economy each year. The parade goes by all the businesses and not many Christian churches ironically so the events are driven by money and balls, titties, beer, and plastic beads. Though I have enjoyed the day time family parades a great deal I do believe Christian leadership is weak. I don't goto church and I am not that great of a Christian but I do see malice. This year the White House elected to display the PRIDE flag on Transgender Day on Easter. There were 4 years of the Biden administration

yet his group elected to display the PRIDE flag on Easter, which was viewed as a deliberate agitation to Christian beliefs. It seems that in Galveston, we were the test bed with the Pride Flag displayed on the Mardi Gras route as well, that was not supposed to be permanent according to the newspaper. Does this agitation promote public health?

My aim is to promote:

- 1) The commission to feel the intense burden of their leadership and ethical responsibility today to public health and healing and to clearly understand the power of collective emotion and how emotion drive people to action.
- 2) Sharing and finding common ground
- 3) Playfulness
- 4) Curiosity about others beliefs and how they feel; this is just the first installment of the art project.
- 5) To focus on light...the common ground ROYGBIV...the rainbow that many groups use as a symbology. I've heard so many people in conservative circles say the gays "took the rainbow" I'm pissed I love rainbows but I'm not homosexual. All I see is light. And no matter what ...every religion and group seem to tap into the light even LGBTQ tapped in and it is being darkened for every group even them by our leadership.
- 6) To promote the feeling of disgust regarding group think mentality which lays waste to individual perspectives within particular groups to find that common ground
- 7) I want to push the LGBTQ group to self-examination of the intentions of their group leadership as much as other groups have been pushed to self-examination. This is not the group I saw asking for basic equal rights to marry and have a family from 20 years ago. When I was a teacher at university of texas in Austin I encouraged students to think about focusing on rights rather than attention seeking behaviors.
- 8) I do think the LGBTQ movement has been insidiously infiltrated by something else that is poisoning their cause that I cannot yet describe. Their current marketing scheme is not actually promoting the welfare, safety, and happiness of the INDIVIDUAL to self-actualize ~~as a whole human~~. Their leadership and marketing of the group has instead limited their entire existence to only their sex and sexuality. They are being reduced to attention seeking behaviors of a few, slapping rainbows on everybody, and making the public funded properties across the world their personal coloring books. For example, Anderson Cooper is a gay reporter. Rosie O Donnell is a lesbian comedian. Elton John is a gay singer. Rachel Maddow is a lesbian reporter. George Strait is a country music singer. Glen Beck is a reporter. Heterosexuals are simply identified by their merit, talents, gifts, and contributions. These people they just use their name. I want them to be mad at your leadership. As well the group think mentality has reduced safety and welfare of all individuals all around by provoking other groups particularly Christians during Easter for some reason. Do you feel more isolated or more safe because of the way the group is operating?

I am not someone who interacts very often socially. I do not want to be here today but someone has got to get us on the road to clarity. I want to talk now about vicarious trauma. We think of living vicariously through someone to be a good thing but we can also live through the trauma with someone. Growing up I lived in a small town and took the bus home each day from school. Only 37 people were in my

graduating class. Along this bus route one house had a female student that was raped by her father, go a bit further a classmate was being molested by his father he should have graduated with my class, he instead hung himself on a tree after his mother shot and killed his father to stop the abuse, where his little brother found him and released his lifeless body from the tree (they were catholic and the two brothers and mom came to church every day after that and sat in the front row everyday after that instance when I had never seen them there before); go a bit further and the baby sitter of one male was sodomizing him, I lived at the end of this road and one of my family members was also raped. I lived with varcarious trauma having known it without experiencing it. Sexual trauma is not something children need to be experiencing. Worry of words and genders, and who they are. I want artists to think about healing people. LGBTQ people are now parents and likely just want their kids for one second not have to think about sex.

Now what do we see with our own City Council. So it is very important to me to get a fair shake here. A flag of a group seemed to be "meritable". I emailed Antoneitte, and it was anything goes, on whatever street you want, all are welcome to submit artwork. I was still not sure, so I submitted a public records request for any possible information on how the PRIDE flag was placed on the street permanently (Im going to say it... It was not art but a group think agenda) It was approved. The city secretary's office stated there were no records it was done on a good ole boy system hand shake and privately funded. I was instead handed a newspaper article to read with a nod this might help you see how things get approved. I read the article which laid out how in ~~2017~~-2019 this was contemplated and executed. It was the "dream" of this group to paint the street. I thought the dream was to have a family, get married, have equal rights not coloring books called streets. I was astonished to find tax payer funded property was sold for so cheap (cost of supplies and labor) for a group flag. I have posed several questions, what if I want to paint in front of the bar that keeps making noise to remember those her are noise sensitive with PTSD, what if Free Palestine wants to place a flag on the ground because they don't want war, or perhaps a Buddhist Swatiska that could be mistook for hilter. Antoinette stated anyone was welcome to submit any art they wish for any road. And so I did. I got a bit of push back on the next emails...well we're having trouble with groups maintaining there art, you really need to get approval from peole where it is going to be located by, who is the group supporting this, um it's an every evolving target and we would love feed back. HMMM HUM. There are currently no rules that I have to abide by. ~~Further+ read anyone can submit a design even if you don't live in Galveston and the residents will just have to live with it.~~ As far as the written criteria displayed on the city website. I only saw specify color, location, and specification of size and what group of people are supporting this on the application as well as maintenance plan for judgement criteria. Again you are only supposed to judge artistic merit.

- 1) Newsflash: The entire ROYGBIV Crayola box is on the ground the statement is null.
- 2) The dimensions are at least 2 crosswalks, 4 lanes and a media wide.
- 3) Location: Prime real estate for billboards is obviously the parade route in front of city hall
- 4) Group think is irrelevant given the city isn't paying for it so you don't need to know who's paying for it or what group to judge artistic merit
- 5) Antoniette mentioned in an email the city is having trouble with others maintaining their artwork so that maintanence plan is also null as other groups have apparently never submitted a five year or 10 year maintenance plan.
- 6) What materials to you plan to use for the art on the street...you should tell me the type of paint and materials that are approved. That is null.

7) In other words I basically am asking for equal. As all citizens should have. However, I too want the prime real estate.

So my project shows Noah's ark and the common symbol of god's promise ...the rainbow which we share with LGBTQ- roygbiv...the light. I tried to give a playful perspective of Mario cart for the kids and Jesus pulling a Noah's ark like a boat trailer or mardis graw float.

Other installments should come from other groups that also use the rainbow to provoke childrens curiosity about light and how others recognize it. Take for instance the Navaho nation when they see a rainbow they hold up a thumb and trace it in the sky as a connection to life and god as see it as a circle of protection. Hawaiians use the rainbow to symbolize the celestial path that god comes down. Islam discusses light and daily prayers focus on the sun cycle. The Jewish Zohar focuses on light as well. A leprachan with a pop of gold that the tax man steals from. Rainbow bright, lucky charms, We can go on and on. Take the stress off of the fear from being misidentified and look for common ground. *We are all turning into the light*
My concerns for the art are safety with so many colors in front of city hall there is a school nearby and if one were wearing colorful clothing a small child may not be visible. Crosswalk visibility for service animals and the disabled need further research.

Alternative iterations we could discuss the LGBTQ group to paint different perspectives on RoyGBIV since they aren't maintaining it to reach that common ground could share that burden together.

We obviously cannot remove artwork without being said hate crime, You cannot deny one protected class from another without being a civil rights concern. so we have to find common ground, but we can think of others feelings a bit more as a public health concern. Our leadership needs to take time to get clear on this. Remember you aren't denying me anything and Jesus is very used to being denied. But I will say straighten it up butter cut. Write an ethics statement for art displays in our environment. We are Americans and no one group has all the rights to public roads. Especially prime real estate.

The other option is all Christians reroute Tillmans parade to go in front of the churchs more.

City of Galveston



City Attorney's Office

P.O. Box 779 / Galveston, Texas 77553-0779 / (409) 797-3530 / Fax (409) 797-3531

Date: February 27, 2025
To: City Council
Brian Maxwell, City Manager
From: Mehran Jadidi, Assistant City Attorney
Re: **City Council Consideration of Sidewalk Art**

Section 32-3 of the Code of the City of Galveston states “Artists or Organizations who desire to draw, paint or otherwise place a work of art on city pavement, including a street or sidewalk, must apply to the city cultural arts commission and provide an outline of their proposal, including a rendition of the proposal and proposed location, description of materials to be used and any other information the artist deems relevant. The cultural arts commission which will evaluate the artistic merit of the proposal and issue its recommendation to city council.”

In December 2024, an Artist, Madonna Mamerow, applied to the Cultural Arts Commission for her artwork to be on a sidewalk. The Commission considered her application and recommended denial based on the incompleteness of the application.

As City Council is the final arbiter on whether to allow a project to progress, it is now in the purview of City Council to accept or reject Ms. Mamerow's application.

Recommendation

- A. Approve Ms. Mamerow's application and allow her to put her work on a sidewalk.
- B. Reject Ms. Mamerow's application.

Respectfully submitted,

Mehran Jadidi



City of Galveston

DEVELOPMENT SERVICES DEPARTMENT

Kyle Clark, Coastal Resources Manager

kclark@galvestontx.gov | Office Number: (409) 797-3563 | www.galvestontx.gov

Date February 27, 2025

To: City Manager
Mayor and City Council Members

From: Kyle Clark
Coastal Resources Manager
Development Services Department

Project location: West end of Galveston Island (Sunbather Lane west 1.7-miles)

Project: Acceptance of additional grant funds from Texas General Land Office (GLO) for the beneficial use of maintenance dredge material as an option to the U.S. Army Corps of Engineers' (USACE) Houston Ship Channel maintenance dredging.

Request:

Consider for approval a resolution of the City of Galveston (COG) authorizing acceptance of additional grant funds from GLO in the amount of \$5,586,852.00. This grant is for COG's cost share for the Project Partnership Agreement (PPA) with U.S. Army Corps of Engineers Galveston District (USACE) for beneficial use of maintenance dredge material, associated with a 1.7-mile-long beach nourishment project; authorizing the City Manager to execute all required documents upon the review and approval of the City Attorney.

Prior Council Action

City Council approved the PPA with USACE at the June 27, 2024, City Council Meeting.

Background

The COG signed a PPA with USACE that would beneficially utilize maintenance dredge material for a beach nourishment project on the west end of Galveston Island. The project location begins at Sunbather Lane and proceeds 1.7 miles to the west.

The beach nourishment project is authorized under Section 204 of the Water Resources Development Act of 1992, or otherwise known as Continuing Authorities Program (CAP) 204.





City of Galveston

DEVELOPMENT SERVICES DEPARTMENT

Kyle Clark, Coastal Resources Manager

kclark@galvestontx.gov | Office Number: (409) 797-3563 | www.galvestontx.gov

Under the CAP 204 program, USACE is authorized to implement projects to reduce storm damage to property that is in connection with dredging for the construction or operations and maintenance of an existing authorized Federal navigation project. There is a ten million dollars (\$10,000,000) federal project limit for USACE.

The COG received a previous seven million dollars (\$7,000,000) GLO Coastal Erosion Planning & Response Act (CEPRA) grant to cover design and implementation costs over the USACE authorized funds.

An additional \$5,586,852.00 is being requested, as additional fees, after the maintenance dredging contract bid was evaluated by USACE. The additional funds have been approved by GLO's Commissioner.

Fiscal Impact Report

There is no charge for accepting the additional GLO grant funds.

Alternatives in order of Priority

- A. Approve the resolution authorizing the City of Galveston to accept additional grant funds from Texas General Land Office (GLO) a beneficial use of maintenance dredge material project with the U.S. Army Corps of Engineers (USACE), on a 1.7-mile-long beach nourishment project and authorizing the City Manager to sign all required documents upon review and approval of the City Attorney.
- B. Do not approve the resolution authorizing the City of Galveston to accept additional grant funds from Texas General Land Office (GLO) a beneficial use of maintenance dredge material project with the U.S. Army Corps of Engineers (USACE), on a 1.7-mile-long beach nourishment project and authorizing the City Manager to sign all required documents upon review and approval of the City Attorney.

Recommendation

- C. Approve the resolution authorizing the City of Galveston to accept additional grant funds from Texas General Land Office (GLO) a beneficial use of maintenance dredge material project with the U.S. Army Corps of Engineers (USACE), on a 1.7-mile-long beach nourishment project and authorizing the City Manager to sign all required documents upon review and approval of the City Attorney.



RESOLUTION NO. 25 - _____

A RESOLUTION OF THE CITY OF GALVESTON AUTHORIZING ACCEPTANCE OF ADDITIONAL GRANT FUNDS FROM THE TEXAS GENERAL LAND OFFICE (GLO), FOR THE BENEFICIAL USE OF MAINTENANCE DREDGE MATERIAL, ASSOCIATED WITH A 1.7 MILE LONG BEACH NOURISHMENT PROJECT; AUTHORIZING THE CITY MANAGER TO EXECUTE ALL REQUIRED DOCUMENTS, UPON FINAL APPROVAL OF THE CITY ATTORNEY; PROVIDING FOR FINDINGS OF FACT AND PROVIDING FOR AN EFFECTIVE DATE.

WHEREAS, the 1992 Water Resources Development Act (WRDA) Section 204, also known as the Continuing Authorities Program Section 204, (CAP 204) authorized the U.S. Army Corps of Engineers (USACE), to implement projects for the protection, restoration and creation of aquatic and ecologically related habitats, including wetlands. In addition, USACE is authorized to reduce storm damage to property in connection with dredging for the construction or operations and maintenance of an authorized federal navigation project. The federal project maximum funding limit is ten million dollars, (\$10,000,000.); and,

WHEREAS, City Council at its June 27, 2024, meeting, per City Resolution No. 24-020, approved entering into a Project Partnership Agreement (PPA) with USACE; and,

WHEREAS, the COG received a previous seven million dollars (\$7,000,000) in GLO Coastal Erosion Planning & Response Act (CEPRA) grant to cover design and implementation costs over the USACE authorized fund; and,

WHEREAS, an additional \$5,586,852.00 is being requested, as additional fees, after the maintenance dredging contract bid was evaluated by USACE. The additional funds have been approved by the GLO; and,

WHEREAS, the preferred placement for the beneficial use of dredge material beach nourishment will be the west end of Galveston Island, beginning at Sunbather Lane and proceeding for 1.7 miles west; and,

WHEREAS, the City Council finds that it is in the public's interest to accept the additional grant funds from the Texas General Land Office (GLO) for the beneficial use of maintenance dredge material, associated with a 1.7 mile long beach nourishment project and to authorize the City Manager to execute all required documents, upon final approval of the City Attorney.

NOW, THEREFORE, BE IT RESOLVED BY THE CITY COUNCIL OF THE CITY OF GALVESTON, TEXAS:

SECTION 1. The findings and recitations set out in the preamble to this Resolution are found to be true and correct and are hereby adopted by the City Council and made a part hereof for all purposes.

SECTION 2. The City Council of the City of Galveston, Texas, authorizes the City Manager to accept the additional grant funds from the Texas General Land Office (GLO), for the beneficial use of maintenance dredge material, associated with a 1.7 mile long beach nourishment project and authorizes the City Manager to execute all required documents, upon final approval of the City Attorney.

SECTION 3. This Resolution shall be and become effective from and after its adoption in accordance with the provisions of the Charter of the City of Galveston.

APPROVED AS TO FORM:

DONNA M. FAIRWEATHER
SR. ASSISTANT CITY ATTORNEY

I, Janelle Williams, Secretary of the City Council of the City of Galveston, do hereby certify that the foregoing is a true and correct copy of a Resolution adopted by the City Council of the City of Galveston at its Regular Meeting held on February 27, 2025, as the same appears in records of this office.

IN TESTIMONY WHEREOF, I subscribe my name hereto officially under the corporate seal of the City of Galveston this _____ day of _____, 2025.

Secretary for the City Council
of the City of Galveston

RESOLUTION NO. 25 - ____

A RESOLUTION OF THE CITY COUNCIL OF THE CITY OF GALVESTON, TEXAS APPROVING A MEMORANDUM OF UNDERSTANDING BETWEEN THE CITY OF GALVESTON AND ITS FIRE DEPARTMENT WITH THE BROADWAY MONUMENT, LLC – MARY MOODY NORTHEN ENDOWMENT, FOR USE OF A LOT FOR SPECIAL EVENTS, TRAINING, AND EDUCATIONAL PURPOSES; APPROVING AND AUTHORIZING THE CITY MANAGER TO EXECUTE THE AGREEMENT; PROVIDING FOR FINDINGS OF FACT AND PROVIDING FOR AN EFFECTIVE DATE.

WHEREAS, the City of Galveston and its Fire Department desire to use the property/lot located at 2529 Sealy, for special events, training and educational purposes. The use of the lot would be a great benefit for multiple departments within the City of Galveston; and,

WHEREAS, the property owner is the Broadway Monument, LLC – Mary Moody Northen Endowment, and they have agreed to said use by the City, in accordance with the attached Memorandum of Understanding; and,

WHEREAS, the City of Galveston is required to have an agreement in place to extend the liability coverage provided by the Texas Municipal League Intergovernmental Risk Pool (TMLIRP) to Broadway Monument LLC/ Mary Moody Northen Endowment for the use of the lot located. Broadway Monument LLC., can then be listed as an insured party; and,

WHEREAS, there is no cost to the City and the City agrees to maintain applicable insurance for the duration of the agreement; and,

WHEREAS the City Council finds it in the public interest that the City of Galveston enter into the proposed Memorandum of Understanding in substantially the same form as attached hereto.

NOW, THEREFORE, BE IT RESOLVED BY THE CITY COUNCIL OF THE CITY OF GALVESTON, TEXAS:

SECTION 1. The findings and recitations set out in the preamble to this Resolution are found to be true and correct and are hereby adopted by the City Council and made a part hereof for all purposes.

SECTION 2. That the Memorandum of Understanding between the City of Galveston and the Broadway Monument, LLC – Mary Moody Northen Endowment, attached hereto as **Exhibit 1**, is hereby approved and adopted.

SECTION 3. There is no cost to the city from the Property Owner and the City shall list the property as an additional insured under its Texas Municipal League Intergovernmental Risk Pool (TMLIRP).

SECTION 4. That the City Manager is hereby authorized to execute the Memorandum of Understanding agreement in substantially the same form as attached hereto upon final approval by the City Attorney.

SECTION 5. That this Resolution shall be and become effective from and after its adoption.

APPROVED AS TO FORM:

DONNA M. FAIRWEATHER
SR. ASST. CITY ATTORNEY

I, Janelle Williams, Secretary of the City of Council of the City of Galveston, do hereby certify that the foregoing is a true and correct copy of a Resolution adopted by the City Council of the City of Galveston at its Regular meeting held on February 27, 2025, as the same appears in records of this office.

IN TESTIMONY WHEREOF, I subscribe my name hereto officially under the corporate seal of the City of Galveston this _____ day of _____, 2025.

Secretary for the City Council
of the City of Galveston

**MEMORANDUM OF UNDERSTANDING
THE CITY OF GALVESTON - FIRE DEPT.
SITE AGREEMENT**

This Memorandum of Understanding is made and entered into between the City of Galveston and Property Owner, The Broadway Monument LLC/ Mary Moody Northen Endowment.

WHEREAS, the City of Galveston and its Fire Department desire to use the property/lot located at 2529 Sealy, for special events, training and educational purposes. The use of the lot would be a great benefit for multiple departments within the City of Galveston.

WHEREAS, the property owner has agreed to said use by the City.

WHEREAS, the City of Galveston is required to have an agreement in place to extend the liability coverage provided by the Texas Municipal League Intergovernmental Risk Pool (TMLIRP) to Broadway Monument LLC/ Mary Moody Northen Endowment for the use of the lot located. Broadway Monument LLC., can then be listed as an insured party.

The following sets out the terms and conditions as mutually agreed between the parties.

Purpose: To allow the Galveston Fire Department, and applicable departments, to use the lot located at 2529 Sealy for special events, training and educational purposes.

Property Site: The site is hereby defined as lot/property located at 2529 Sealy and legally described as ABST 628 M B Menard Sur Lots 1 thru 4 Blk 205, in the City of Galveston. The site is accepted by the city in its “as is” condition and the property owner makes no representations, statements, warranties, (express or implied) in respect to its condition and has no further responsibility or liability for latent defects or general conditions.

Term: The term of this agreement is in effective upon the execution by the parties and shall continue unless terminated in writing by either party, as provided herein.

Use of Property: The City will use the site for special events, training and educational purposes, as determined by the City. The Owner grants to the City and its authorized representatives a right of ingress and egress to the property as described herein on a twenty-four (24) hour basis.

Cost: The Parties agree that there is no rent or any other compensation due to the Property Owner from the City under this agreement.

Indemnity and Insurance: The City agrees to indemnify and hold harmless the Property Owner and the Mary Moody Northen Endowment, its agents, directors and employees from any and all claims, damages, liabilities, or expenses arising out of the City’s use of the Property and any act of omission or negligence of City, its agents, invitees or employees while on and using the Property or Property. The city will maintain TMLIRP Insurance for the duration of this agreement. The city will provide a certificate of insurance evidencing the coverage. The city’s insurance shall be primary coverage, without any right of contribution from any insurance carried by the Property Owner. The city agrees to include the Property Owner and the Mary Moody Northen Endowment as additional insureds on the insurance coverage evidenced herein.

Care of the Property: City will provide for the physical security of the Property, the contents, the facilities, and City's personnel during the period of time that the City occupies the Property. Property Owner shall have no responsibility for same.

Termination of Agreement: This agreement shall automatically renew annually. Either Party may terminate this agreement upon provision of 14 days written notice of their intent to terminate and the date thereof.

Return of property to Property Owner: City shall return the Property to the Property Owner promptly at the termination of this agreement clear of any of City's portable or temporary facilities, contents or possessions in substantially the same condition in which it was received, ordinary wear and tear excepted.

Assignment of Agreement: City shall not, without the Property Owner's prior written consent, sublet or assign the Property or any part thereof.

All notices required under this Agreement shall be in writing and deemed given when delivered in person, by electronic mail (email), or three days after deposit in the United States Mail, postage prepaid, addressed to the party's address/notice information reflected below. A copy of the notices shall be sent to:

City of Galveston

Broadway Monument, LLC
Mary Moody Northen Endowment

Attn. City Manager
823 Rosenberg, Room 203
P.O. Box 779
Galveston, Texas 77553

Attn. Betty Massey, Executive Director
Address: 2618 Broadway
Galveston, Texas 77553
Phone Number: 409-261-3124

Email: Citymanager@cityofgalvestontx.gov

Email: b.massey@northenendowment.org

With copy to the Fire Chief
Email: MVarela@galvestontx.gov

IN WITNESS WHEREOF, the respective parties hereto have caused this Agreement to be duly executed as of the date first herein written.

CITY:

PROPERTY OWNER:

City of Galveston

Broadway Monument, LLC
Mary Moody Northen Endowment

By: _____
Name: Brian Maxwell
Title: City Manager

By: _____
Name: Betty Massey
Title: Executive Director

Approved As To Form:

City Attorney's Office



Galveston Fire Department

STAFF REPORT

Date February 05, 2025

To: Brian Maxwell, City Manager
Mayor and City Council Members

From: Mike Varela Jr., Fire Chief

Request:

Consider for Approval of an MOU between the City of Galveston and Broadway Monument LLC/ Mary Moody Northen Endowment for the use of the lot located at 2529 Sealy for special events, training, and educational purposes. Authorizing the City Manager to execute all necessary documents upon final approval by the City Attorney.

Prior Council Action

- N/A

Background

- The Galveston Fire Department has requested the use of the lot located at 2529 Sealy for special events, training and educational purposes.
- The use of the lot would be a great benefit for multiple departments within the City of Galveston.

Current Situation

- The Broadway Monument LLC/ Mary Moody Northen Endowment has requested that the City of Galveston provide a certificate of liability coverage while using the facilities for special events, training, and educational purposes.
- The City of Galveston is required to have an agreement in place to extend the liability coverage provided by TMLIRP to Broadway Monument LLC/ Mary Moody Northen Endowment for the use of the lot located at 2529 Sealy.





Galveston Fire Department

STAFF REPORT

Fiscal Impact

- There would be no cost to the City of Galveston.
- With the use of this Memorandum of Understanding, TMLIRP would provide the required liability coverage with the Council approved agreement with Broadway Monument LLC listed as an insured party.

Alternatives

- City Council approves the MOU between The City of Galveston and Broadway Monument LLC/ Mary Moody Northen Endowment for the use of lot located at 2529 Sealy for special events, training and educational purposes.
- City Council takes no action and forfeits any use of the lot.

Staff Recommendation

- Approve the MOU between The City of Galveston and Broadway Monument LLC/ Mary Moody Northen Endowment for the use of lot located at 2529 Sealy for special events, training and educational purposes.

Attachments

- Memorandum of Understanding
- Resolution





City Marshal's Office

CITY OF GALVESTON
823 Rosenberg | Galveston, TX 77550-0779
www.galvestontx.gov | 409-797-3660

1/29/25

To: Brian Maxwell, City Manager
Honorable Mayor and City Council Members

From: Nick Yeley, Interim City Marshal

RE: Consider for approval the ratification of \$27,000 for the emergency demolition of the structure located at 1604 Market in Galveston, TX. The demolition was performed by Nunn Excavation Company and paid for using the funds approved in the Marshals Office budget 0100-261000-531121-423800. The City will place a lien on the property to recoup our expenses.

I. Background

- A. There have been numerous complaints at 1604 Market dating back as far as 2010.
- B. We have filed charges for multiple ordinance violations however the property has continued to deteriorate over the years.
- C. The structure caught fire in August 2024 and the property was condemned due to the damage caused by the fire.
- D. We obtained a court order authorizing the City of Galveston to demolish the structure on the property for public safety due to the damage to the structure from the fire. This court filing was completed 12/4/24.
- E. The demolition was scheduled due to the unsafe condition of the structure and the hazard to the neighboring structures and the public.
- F. The demolition was accomplished utilizing manual labor and heavy equipment due to the proximity to other structures.
- G. The price of \$27,000 is the quoted price for emergency demolition of the structure.

II. Current Situation

Consider for approval the ratification of \$27,000 for the emergency demolition of the structure located at 1604 Market in Galveston, TX. The demolition was performed by Nunn Excavation Company and paid for using the funds approved in the Marshals Office budget 0100-261000-531121-423800. The City will place a lien on the property to recoup our expenses.





City Marshal's Office

CITY OF GALVESTON
823 Rosenberg | Galveston, TX 77550-0779
www.galvestontx.gov | 409-797-3660

III. Issues

- A. Cost – \$27,000 utilizing Nunn Excavating Company
- B. Timing – The structure has many structural issues and needs to be demolished due to its unsafe condition. It has begun to collapse and could damage other properties or hurt pedestrians near the structure.
- C: Departmental Improvements – By demolishing this structure it eliminated many complaints and the danger to the public.

IV. Alternatives in order of priority

- A. Approve the direct payment to Nunn Excavating Company for emergency demolition.
- B. Do not approve the direct payment to Nunn Excavating Company.

V. Recommendation

Alternative A

Consider for approval the ratification of \$27,000 for the emergency demolition of the structure located at 1604 Market in Galveston, TX. The demolition was performed by Nunn Excavation Company and paid for using the funds approved in the Marshals Office budget 0100-261000-531121-423800. The City will place a lien on the property to recoup our expenses.

VI. Fiscal Impact Report

Requested by: Nick Yeley
Interim City Marshal

Funding Source: **Marshals Office budget**
0100-26100-531121-423800

Cost of Implementation: \$27,000.00

Additional Information: This property was scheduled for emergency demolition due to the damaged structure from the fire. It has become a danger to the surrounding buildings and people.

Respectfully Submitted,



City Marshal's Office



Nick Yeley
Interim City Marshal

CITY OF GALVESTON
823 Rosenberg | Galveston, TX 77550-0779
www.galvestontx.gov | 409-797-3660



JANUARY 24, 2025

PHIL NUNN

NUNN EXCAVATION

CITY OF GALVESTON

ATTN: BUTCH STROUD

NICHOLAS YELEY

INVOICE

TO BILL YOU FOR THE DEMOLITION OF REMAINING STRUCTURE LOCATED AT 1604 MARKET STREET
, GALVESTON, TEXAS 77550.....\$ 27,000

TOTAL AMOUNT DUE UPON COMPLETION..... \$27,000

PLEASE MAKE ARRANGEMENTS WITH PHIL NUNN TO COLLECT PAYMENT

PHIL NUNN

409 771 9666



City of Galveston

DISASTER RECOVERY AND GRANTS

Tesa Wroblewski, Director of Disaster Recovery & Grants
twroblewski@galvestontx.gov | Office Number: (409) 797-3517 | www.galvestontx.gov

02/4/2025

**To: Brain Maxwell, City Manager
Hon. Mayor and City Council Members**

From: Tesa Wroblewski, Director of Disaster Recovery and Grant

RE: Consider for the issuance of Task Order #4 to Plexos Group, LLC for the Grant Administration Services related to the Texas General Land Office (GLO) Community Development Block Grant – Mitigation (CDBG-MIT) for the South Shore Drainage Improvement Project in the amount of \$678,875.00 and authorizing the City Manager to execute all necessary documents.

I. Prior City Council Action

- A. City Council approved Task Order #1 (\$814,650.00) to Plexos Group, LLC January 27, 2022.
- B. City Council approved Task Order #2 (no cost) to Plexos Group, LLC July 28, 2022.
- C. City Council approved Task Order #3 (\$814,650.00) to Plexos Group, LLC August 22, 2024.

II. Background

- A. As a result of heavy rainfall and flooding from Hurricane Harvey throughout the State of Texas over an extended period of time in August 2017 the City was eligible to apply for funding from the Texas General Land Office (GLO) through the Community Development Block Grant (CDBG-MIT) statewide competition.
- B. The City applied for and was awarded funding under this competition for the South Shore Drainage Project.
- C. The City was awarded \$54,309,999.00 in CDBG-MIT funding and entered into a contract with the GLO on December 1, 2021.
- D. The City previously issued three Task Orders for grant administration services in support of Phases 1 through 4 of the project, which included project setup, design, environmental review, and procurement services.





City of Galveston

DISASTER RECOVERY AND GRANTS

Tesa Wroblewski, Director of Disaster Recovery & Grants
twroblewski@galvestontx.gov | Office Number: (409) 797-3517 | www.galvestontx.gov

III. Current Situation

- A. Work under all previous task orders has been completed.
- B. The South Shore Drainage Improvement Project is entering the next phase of work which is construction.
- C. The cost of services for Plexos Group, LLC's support of grant management and administration during the construction phase is reimbursable under the CDBG-MIT grant from GLO.

IV. Issues

Task Order 4 is required to obtain continued grant management and administrative support throughout the construction phase of the project.

V. Alternatives in order of Priority

- A. Approve Task Order #4 for Plexos Group, LLC for Grant Administrative Services for the GLO CDBG-MIT South Shore Drainage Improvement Project in the amount of \$678,875.00 and authorize the City Manager to execute all necessary documents.
- B. Do Not Approve Task Order #4 for Plexos Group, LLC for Grant Administrative Services for the GLO CDBG-MIT South Shore Drainage Improvement Project in the amount of \$678,875.00 and authorize the City Manager to execute all necessary documents.

VI. Fiscal Impact Report

Funding Source	Amount
1711-611800-531004-445000 With Reimbursement from the GLO	\$678,875.00

VII. Recommendation

- A. Approve Task Order #4 for Plexos Group, LLC for Grant Administrative Services for the GLO CDBG-MIT South Shore Drainage Improvement Project and authorize the City Manager to execute all necessary documents.





City of Galveston
South Shore Drainage Project (CDBG-MIT)
Task Order 4

Background

The City of Galveston (city) approved and entered into a grant administration contract (#20-075) with Plexos Group, LLC (Plexos) on June 1, 2020, and an extension of that contract which became effective June 1, 2024. The contracted services include support of the city through the development of competitive applications for funding to be submitted to the Texas General Land Office (GLO) for the statewide CDBG-MIT funding competition and the subsequent management and administration of funds procured through the competitive grant process.

Plexos prepared and submitted an application for the South Shore Drainage project. As a result of the application, the city was awarded CDBG-MIT funding in the amount of \$54,309, 999.00. The city entered a contract with the GLO for the South Shore Drainage Project on December 1, 2021.

On January 27, 2022, the city issued Task Order 1 in the amount of \$814,650.00 to support the design portion of the project. Task Order 1 covered Phase 1 (Project Setup) and Phase 2 (Commencement of Design). Plexos provided administrative and compliance support for the setup of the project and throughout the project design phase. All work under Task Order 1 has been completed.

On July 28, 2022, the city issued Task Order 2 as a no-cost task order to develop a Uniform Relocation Act (URA) Plan in support of the temporary construction easements that would be necessary for project implementation. Plexos developed the URA Plan and submitted it to the city. The city approved the URA Plan on October 26, 2023.

Task Order 3 was issued on August 22, 2024, in the amount of \$814,650.00. It addressed the required elements of Phases 3 (Completion of Environmental Review) and 4 (Commencement of Construction Bid) of the project.

Current Project Need

All work under Task Order 3 for Phases 3 and 4 of the project has been completed and the project is entering Phase 5 (Commencement of Construction), requiring the issuance of Task Order 4. Task Order 4 is in the amount of \$678,875.00 and is fully reimbursable to the City through grant funds. Subsequent project phases (6-Completion of Construction and 7-Grant

Closeout) will be awarded on a task order basis, upon completion of all tasks under Task Order 4. Table 1 illustrates the tasks and associated cost of the work.

Table 1: Task Order Breakdown for Phase 5 Commencement of Construction

South Shore Drainage Project (Contract No.20-075) Task Order 4			
Phase 5 Commencement of Construction			Cost
5.a	Assist the city with issuance of NTP.	25.00%	\$ 678,875.00
5.b	Assist city with any pre-construction meetings, providing construction-specific grant compliance requirements.		
5.c	Review construction contractors policies, procedures, and processes for compliance with grant terms and conditions.		
5.d	Provide technical assistance to contractors in relation to grant specific reporting (Section 3, Davis Bacon, EEOC, etc.)		
5.e	Conduct onsite inspections and interviews to verify grant compliance.		
Grant Administrator Activities Completed Monthly to include:			
5.f	Overall Project Development and Grant Administration in compliance with HUD CDBG-MIT requirements and GLO policies, including monthly, quarterly and yearly reporting.		
5.g	Coordination, as necessary, between the city and any other appropriate service providers (i.e., Engineer, Environmental, etc.), contractor, subcontractor and GLO to effectuate the services requested in compliance with program compliance.		
5.h	Support draw request preparation, review, and submission		
5.i	Support DBRA compliance review and reporting.		
5.j	Support construction contract monitoring.		

Signed:

 Brian Maxwell, City Manager
 City of Galveston

 Date

 David F. Odom, President and Chief Executive Officer
 Plexos Group, LLC

 Date

 Donald Glywasky, City Attorney
 City of Galveston

 Date



City of Galveston

PARKS, RECREATION & COMMUNITY OUTREACH STAFF REPORT

Date: February 18, 2025

To: City Manager, Mayor and City Council Members

From: Barbara Ekelund-Sanderson,
Executive Director of Parks, Recreation & Community Outreach

Project location: McGuire-Dent Recreation Center & Various Athletic Fields **Project:** Memberships and Rental Fees at McGuire-Dent Recreation Center and Various Athletic Fields and Courts.

Request: Consider for Approval changes to membership and rental fees at McGuire-Dent Recreation Center, and various athletic fields and courts under the management of the Parks and Recreation Department and designating special revenue accounts for revenue earned at each location; authorizing the City Manager to execute all necessary documents upon final approval by the City Attorney.

Prior Council Action

City Council last approved the increase of fees at McGuire-Dent and various athletic fields in 2022 and approved an increase of fees at Lasker Park Pool last month (January 2025).

Background

The City of Galveston Parks and Recreation Department's mission is to create, promote, administer, and maintain exceptional recreational programs, facilities, and parks. Primary funding for operations is through the General Fund. Additional funding is derived from grants, the Industrial Development Corporation, donations, and revenue generated.

Currently, most revenue generated from rentals goes to the City's General Fund and is not designated back to the Parks and Recreation Department, or the location from which that revenue was earned. Staff would like the revenue made at each location to be placed into a special revenue fund that would roll from year to year and be dedicated specifically to improvements at the location the revenue was earned from. This does occur already at McGuire-Dent Recreation Center, where revenue generated goes directly into a special revenue fund specifically for McGuire-Dent Recreation Center, for the purchase of new equipment, repairs to existing equipment, and general improvements at the facility.

Staff evaluates fees charged annually and is proposing new rates at these locations. If City Council approves, the proposed fee changes would go into effect on April 1, 2025.

The following pages will detail the current and proposed changes:

McGuire-Dent Recreation Center (Page 2)

Menard Park Band Shell (Page 3)

Athletic Field Rentals (Pages 4-6)

Tennis Court Rental Fees (Page 7)





City of Galveston

PARKS, RECREATION & COMMUNITY OUTREACH STAFF REPORT

McGuire-Dent Recreation Center Membership Fees

Membership fees for McGuire-Dent Recreation Center were established and approved by City Council in 2019. In 2022, City Council approved the increase of membership fees to the current fees listed below. 100% of the revenue generated from memberships goes to the purchase of new fitness equipment, repairs to existing equipment, and facility improvements.

Wright Cuney Recreation Center remains free to the public regardless of age. Local resident holders of annual pool passes will continue to receive a \$5.00 discount on the purchase of a McGuire-Dent Recreation Center annual pass.

Between February 1, 2024 and January 31, 2025, staff at McGuire-Dent Recreation Center registered or renewed annual passes for 4,769 adults, 696 military (active, retired, and spouses), 2,285 seniors, 1,029 youth and 1,579 daily pass users for a total of 10,358 members. These 10,358 members “checked-in” to the facility a total of 111,798 times during the same period.

Current Membership Fees

Type of Membership	Residents				Non-Residents			
	Adult (18-64)	Youth (5-17)	Senior (65+)	Military	Adult (18-64)	Youth (5-17)	Senior (65+)	Military
Daily Pass	\$5	FREE	FREE	FREE	\$5	FREE	\$5	FREE
Annual Pass	\$30	FREE	FREE	FREE	\$65	FREE	\$65	FREE

Membership fees include all programs and activities, free of additional charge.

Proposed Membership Fees

Type of Membership	Residents				Non-Residents		
	Adult (18-64)	Youth (5-17)	Senior (65+)	Military	Adults & Seniors (18+)	Youth (5-17)	Military
Daily Pass	\$5	FREE	FREE	FREE	\$5	FREE	FREE
Annual Pass	\$50	FREE	FREE	FREE	\$85	FREE	FREE

Membership fees include all programs and activities, free of additional charge.

The proposed increase would continue to provide year-round programs and services for a reasonable amount of \$4.17 per month for an annual adult residential pass and \$7.08 per month for an annual non-residential pass. Annual passes run from the purchase date through the same date the following year.

If approved, the proposed adult annual membership fees would increase on April 1, 2025.





City of Galveston

PARKS, RECREATION & COMMUNITY OUTREACH STAFF REPORT

Menard Park Band Shell Rentals

Staff recommends an increase in the rental fees of the Menard Park Band Shell. Currently, revenue collected from the rentals is deposited to the City's General Fund.

Current Band Shell Rental Fees

Description	Rate
Band Shell Rental per every 3-4 Hours	\$75

- Includes access to electricity.
- Subject to availability.
- Must be scheduled at least 10 business days in advance of rental period.
- Must be approved by the Executive Director of Parks, Recreation & Community Outreach.
- Applicant may be required to obtain Loudspeaker Permit for the duration of the rental period, depending upon the nature of the rental.

Proposed Band Shell Rental Fees

Description	Rate
Band Shell Rental per every 3-4 Hours	\$150

- Includes access to electricity.
- Subject to availability.
- Must be scheduled at least 10 business days in advance of rental period.
- Must be approved by the Executive Director of Parks, Recreation & Community Outreach.
- Applicant may be required to obtain Loudspeaker Permit for the duration of the rental period, depending upon the nature of the rental.

Additionally, staff recommends that revenue collected from the Band Shell Rental Fees be deposited to a Special Revenue account specifically for repairs or improvements to the Band Shell.





City of Galveston

PARKS, RECREATION & COMMUNITY OUTREACH STAFF REPORT

Athletic Field Rentals

Current fees for hourly field rentals (for all types of fields owned by the City of Galveston) were approved by City Council in 2022. These rates were established for smaller occasions and requests received outside of tournaments. Currently, revenue collected from the rentals is deposited to the City’s General Fund.

Current Athletic Field Hourly Rates

Description	Rate
Field Rental (with Lights)	\$30 / hour / field
Field Rental (without Lights)	\$20 / hour / field

Proposed Athletic Field Hourly Rates

Staff recommends designating the current fees as non-resident rental fees, and a \$5.00 reduction in residential rental fees. These hourly rental fees would apply to all fields owned by the City, including those for baseball, softball, and soccer purposes.

Residency Status	Hourly Rate without Lights	Hourly Rate with Lights
Resident	\$15 / hour / field	\$25 / hour / field
Non-Resident	\$20 / hour / field	\$30 / hour / field

Additionally, staff recommends that revenue collected from each athletic field be deposited to a Special Revenue account specifically for repairs, improvements or additional expenses related to that athletic field.





City of Galveston

PARKS, RECREATION & COMMUNITY OUTREACH STAFF REPORT

Baseball and Softball Field Rentals

Current fees for baseball and softball field rentals were approved by City Council in 2019, and in 2022, the description for a tournament length changed from 3-day to 2-days, though the rates did not. Staff proposes an increase to the rental fees, as well as the inclusion of a City Employee serving as an attendant responsible for cleaning and stocking restrooms, and trash removal. Currently, revenue collected from the rentals is deposited to the City's General Fund.

Current Baseball & Softball Field Rental Fees

Tournament Sponsor	2 Fields	3 Fields	4 Fields	5 Fields	6 Fields	All Fields
Local Leagues	FREE	FREE	FREE	FREE	FREE	FREE
Resident Promoter (Non-League)	\$325	\$475	\$625	\$775	\$925	\$1075
Non-Resident Promoter	\$450	\$600	\$750	\$900	\$1050	\$1200

- Any tournament is described as a 2-day event. If a proposed tournament runs longer than 2 days, additional fees may be charged.

Proposed Baseball & Softball Field Rental Fees

Tournament Sponsor	2 Fields	3 Fields	4 Fields	5 Fields	6 Fields	All Fields
Local Leagues	FREE	FREE	FREE	FREE	FREE	FREE
Resident Promoter (Non-League)	\$565	\$715	\$865	\$915	\$1165	\$1215
Non-Resident Promoter	\$690	\$840	\$990	\$1140	\$1290	\$1440

- Any tournament is described as a 2-day event. If a proposed tournament runs longer than 2 days, additional fees may be charged.
- Includes attendant responsible for cleaning and stocking restrooms and trash removal for 8 hours total (4 hours each day of the 2-day tournament).

Additionally, staff recommends that revenue collected from each location be deposited to a Special Revenue account specifically for repairs, improvements, or additional expenses related to that location.





City of Galveston

PARKS, RECREATION & COMMUNITY OUTREACH STAFF REPORT

Sandhill Crane Soccer Complex Field Rentals

No rental fees currently exist for Sandhill Crane Soccer Complex fields. Staff proposes establishing rental fees rates per field, with scheduling subject to availability and approval. Staff proposes that revenue collected from Sandhill Crane Soccer Complex be deposited to a Special Revenue account specifically for repairs, improvements, or additional expenses related to the complex.

Additionally, staff recommends requiring a City Employee serve as an attendant for a minimum of four (4) hours and be on site with the responsibility of cleaning and stocking restrooms and removing trash from around the premises. Optional fees are also proposed for marking/lining each field.

Proposed Soccer Complex Rental Fees

Tournament Sponsor	Mini Fields	Field 1	Field 2	Field 3	Field 4	Field 5	All Fields
Local Leagues	FREE	FREE	FREE	FREE	FREE	FREE	FREE
Resident Promoter (Non-League)	\$50/day	\$90/day	\$90/day	\$90/day	\$90/day	\$90/day	\$500/day
Non-Resident Promoter	\$75/day	\$125/day	\$125/day	\$125/day	\$125/day	\$125/day	\$700/day
Plus Required Attendant Fee: \$120/per minimum 4 hours Each additional hour: \$30/per hour <i>Attendant responsibilities include cleaning and stocking restrooms, and trash removal.</i>							
Optional Marking / Lining Fee: \$100/per field							

- The proposed rental fees include lighting at Fields 1 through 5, if desired (the Mini Fields do not currently have lighting availability)
- Rentals will be required to have an attendant on site who will be responsible for cleaning and stocking restrooms, and trash removal for a minimum of 4 hours for \$120.00. Each additional hour will be paid at \$30.00 per hour.

Revenue collected from Sandhill Crane Soccer Complex would be deposited to a Special Revenue account specifically for repairs, improvements, or additional expenses related to the complex.





City of Galveston

PARKS, RECREATION & COMMUNITY OUTREACH STAFF REPORT

Tennis Court Rental Fees

Staff intends to keep the tennis courts in the community free of charge, open to the public, and available first come first serve, whenever possible. Due to a rise in sports tourism, staff proposes establishing fees for exclusive use of the tennis courts, for events such as tournaments.

Because no current rental fees currently exist for exclusive use of tennis courts, staff proposes establishing rental fees per location, rather than per court. The courts available are:

- Menard Park Tennis Courts – 6 Courts
- Lasker Park Tennis Courts – 5 Courts
- Lindale Park Tennis Courts – 3 Courts

Proposed Tennis Court Rental Fees

Tournament Sponsor	Daily Rate without Lights	Daily Rate with Lights
Galveston Schools	FREE	FREE
Other Promoters	\$200 / day / location	\$250 / day / location

Scheduling would be subject to availability and approval. Revenue collected from the courts would be deposited to a Special Revenue account specifically for repairs, improvements, or additional expenses related to the courts.





City of Galveston

PARKS, RECREATION & COMMUNITY OUTREACH STAFF REPORT

Fiscal Impact Report

- **Total Cost.** There is no cost to the City.
- **Funding Source.** N/A

Alternatives

Do not approve changes to membership and rental fees at McGuire-Dent Recreation Center, and various athletic fields and courts under the management of the Parks and Recreation Department and designating special revenue accounts for revenue earned at each location; authorizing the City Manager to execute all necessary documents upon final approval by the City Attorney. Current fees and policies would remain in place.

Staff Recommendation

Staff recommends approving changes to membership and rental fees at McGuire-Dent Recreation Center, and various athletic fields and courts under the management of the Parks and Recreation Department and designating special revenue accounts for revenue earned at each location; authorizing the City Manager to execute all necessary documents upon final approval by the City Attorney.

Respectfully Submitted,

Barbara Ekelund-Sanderson
Executive Director of Parks, Recreation & Community Outreach





City of Galveston

PARKS, RECREATION & COMMUNITY OUTREACH STAFF REPORT

Date: February 19, 2025

To: City Manager, Mayor and City Council Members

From: Barbara Ekelund-Sanderson,
Executive Director of Parks, Recreation & Community Outreach

Project location: Menard Park (2222 28th Street) **Project:** Donation of Suicide Prevention Awareness Bench

Request: Consider for Approval the acceptance of a donation valued at \$1,500.00 from Josh's Benches for Awareness, in collaboration with the American Foundation for Suicide Prevention, for a park bench that raises awareness of suicide prevention, at Menard Park.

Prior Council Action

No Prior Council Action.

Background

Josh's Benches for Awareness is a non-profit, 501(c)(3) organization dedicated to raising awareness on mental health issues and promoting suitable resources to remove the negative stigma surrounding the receiving of help. The benches they build serve as physical symbols that represent any local campaign or movement surrounding mental health and are also safe places for to refer to for help. The benches are bright yellow so that whoever notices them and reads them will know that they are not alone and that there is help out there for them.

Staff was approached by the Walk Chairs for the annual "Hike For Hope Galveston" sponsored by the American Foundation for Suicide Prevention, with a request to accept a donation of a bright yellow park bench from Josh's Benches for Awareness, and to have that bench be placed at Menard Park. "Hike for Hope" is a nationwide campaign event from the American Foundation for Suicide Prevention that provides an opportunity to raise suicide prevention awareness, and foster connections in local communities. The "Hike for Hope Galveston" event date will occur on March 22, 2025 at Menard Park this year.

Josh's Benches for Awareness are located nationwide throughout many communities and states, at parks, schools, and college campuses. There is one other bench located in Galveston at Texas A&M University.





City of Galveston

PARKS, RECREATION & COMMUNITY OUTREACH STAFF REPORT

Fiscal Impact Report

- **Total Cost.** N/A
- **Funding Source.** N/A

Alternatives

Do not approve the acceptance of a donation valued at \$1,500.00 from Josh's Benches for Awareness, in collaboration with the American Foundation for Suicide Prevention, for a park bench that raises awareness of suicide prevention, at Menard Park.

Staff Recommendation

Staff recommends approving the acceptance of a donation valued at \$1,500.00 from Josh's Benches for Awareness, in collaboration with the American Foundation for Suicide Prevention, for a park bench that raises awareness of suicide prevention, at Menard Park.

Attachment(s)

Letter from the Walk Chairs of the "Hike for Hope Galveston" event
Example Photo of Suicide Prevention Awareness Bench

Respectfully Submitted,

Barbara Ekelund-Sanderson
Executive Director of Parks, Recreation & Community Outreach



Galveston City Council
823 Rosenberg St
Galveston, TX 77550

Dear Members of the Galveston City Council,

I am writing to inform you about a generous donation from Josh's Benches for Awareness in collaboration with the American Foundation for Suicide Prevention. Josh's Benches has graciously offered to donate a bench to be placed in Menard Park, the location of the Fourth Annual Hike for Hope which raises funds and awareness for mental health and suicide prevention.

Josh's Bench is a symbol of hope and remembrance, dedicated to the memory of those we have lost to suicide. The bench serves as a place for reflection, solace, and community support. We believe that placing this bench in Menard Park will provide a meaningful space for residents and visitors to find comfort and connection.

We kindly request the City Council's approval to accept this donation and to facilitate the installation of the bench in Menard Park.

Value of Bench: \$1500.00

Dimensions: 90 pounds, 2 feet by 5 feet long, yellow in color

Details: Benches are easy to assemble, takes about 20 minutes – two options for frames – free standing (to attach to cement or existing surface) or permanent post (dig two holes). The bench is made from HDPE recycled plastic lumber; the material doesn't rot like wood or rust like metal. It comes colored therefore it never needs repainted or restained. It is weather and graffiti resistant and we expect it to last for decades.

Thank you for considering this request. We are confident that this addition to Menard Park will be a wonderful addition to our community - promoting awareness and support for mental health and suicide prevention.

Sincerely,
Diane Manley, Stephanie Waltman, Terri Sudduth
346-266-4863 (cell phone – Diane Manley)

Hike for Hope Galveston – Walk Chairs
www.afsp.org/galveston
Josh's Benches for Awareness
<https://joshsbenches.com/>

National Suicide Prevention Lifeline

If You're in Crisis and Want to Talk, Call 988

"You are Not Alone...Help is Available"

joshbeauches.com

[#yellowisforhello](https://twitter.com/yellowisforhello)

RESOLUTION NO. 25-_____

A RESOLUTION OF THE CITY COUNCIL OF THE CITY OF GALVESTON, TEXAS, APPROVING THE 2025 TITLE VI PROGRAM AND POLICIES FOR THE CITY AND ISLAND TRANSIT; PROVIDING FOR FINDINGS OF FACT; AND PROVIDING FOR AN EFFECTIVE DATE.

WHEREAS, pursuant to Title VI of the Civil Rights Act of 1964, and in accordance with 49 CFR Part 21, the U.S. Department of Transportation and the Federal Transit Administration (FTA) prohibit discrimination on the basis of race, color or national origin; and,

WHEREAS, as a recipient of federal funds, the City of Galveston is required to comply with the requirements of the Act and applicable implementing regulations; and,

WHEREAS, pursuant to FTA Circular 4702.1B, and Title VI Requirements the City of Galveston is required to submit its Title VI program to its governing entity for approval; and,

WHEREAS, the City of Galveston has developed the necessary procedures and processes to be in compliance with the Title VI regulations, including a complaint process and a Title VI notice to the public; and,

WHEREAS, the Galveston City Council has considered and determined to approve the City's 2025 Title VI Program and Policies as set forth in the attached **Exhibit A** entitled, "Galveston Island Transit Title VI Program"; and,

WHEREAS, the Council has authority to approve by Resolution the 2025 Title VI Program and Policies; and,

WHEREAS, the City Council finds it in the best interest of the public to approve this Resolution and the 2025 Title VI Program and Policies as set forth in the "Galveston Island Transit Title VI Program" (**Exhibit A**) attached and fully incorporated herein.

NOW, THEREFORE, BE IT RESOLVED BY THE CITY COUNCIL OF THE CITY OF GALVESTON, TEXAS:

SECTION 1. The findings and recitations set out in the preamble to this Resolution are found to be true and correct and are hereby adopted by the City Council and made a part hereof for all purposes.

SECTION 2. The City Council of the City of Galveston, Texas, hereby approves the 2022 Title VI Program and Policies as set forth in the attached **Exhibit A** entitled "Galveston Island Transit Title VI Program", including; but not limited to, complaint

procedures, Title VI notice to the public, Program and activities concerning Limited English Proficient Persons, system-wide service standards and policy monitoring program, as well as, other program elements set forth therein.

SECTION 3. This Resolution shall be and become effective from and after its adoption.

APPROVED AS TO FORM:

XOCHITL VANDIVER-GASKIN,
ASSISTANT CITY ATTORNEY

I, Janelle Williams, Secretary of the City Council of the City of Galveston, do hereby certify that the foregoing is a true and correct copy of a Resolution adopted by the City Council of the City of Galveston at a Regular Meeting held on February 27, 2025, as the same appears in the records of this office.

IN TESTIMONY WHEREOF, I subscribe my name hereto officially under the corporate seal of the City of Galveston this _____ day of _____, 2025.

Secretary for the City Council
of the City of Galveston



City of Galveston

FLEET, MASS TRANSIT & SPECIAL EVENTS STAFF REPORT

Date February 18, 2025

To: City Manager
Mayor and City Council Members

From: David Smith, Executive Director James Oliver
Fleet, Mass Transit and Special Events Island Transit General Manager

Project location: N/A **Project:** Island Transit Title VI

Request: Consider for the approval of a resolution of the City Council of the City of Galveston approving the amended 2025 City of Galveston, Island Transit Title VI Plan as required by The Federal Transportation Administration and the Texas Department of Transportation.

Prior Council Action

No prior actions on this item. The last approval occurred in 2022.

Background

- A. Title VI Plan addresses complaints in reference to discrimination based on race, color and/or national origin and sets in writing the approved procedures on the proper handling of these complaints.
- B. The Federal Transportation Administration and Texas Department of Transportation are requiring local governments to approve a resolution supporting their Title VI Plan to continue to receive funding.
- C. The Title VI Plan must be approved every three years. The plan has been updated to reflect any required changes.

Fiscal Impact Report

Without an approved Title VI resolution, funding can be denied to Island Transit.





City of Galveston

FLEET, MASS TRANSIT & SPECIAL EVENTS STAFF REPORT

Alternatives

A. Approve.

1. Cost - None
2. Timing - As soon as possible.
3. Departmental Improvements - Will allow Island Transit to operate in compliance with FTA and TXDOT requirements.

B. Do not approve.

1. Cost - None
2. Timing - N/A
3. Departmental Improvements - Island Transit will not be able to operate in compliance with FTA and TXDOT requirements and will not receive the required funding.

Staff Recommendation

Concur in *Alternative A*; *approve* the resolution of the City Council of the City of Galveston approving the amended 2025 City of Galveston, Island Transit Title VI Plan as required by The Federal Transportation Administration and the Texas Department of Transportation.

Attachments





**GALVESTON ISLAND TRANSIT
TITLE VI PROGRAM**

UPDATED 01/27/2025

Contents

SECTION 1: Introduction	3
SECTION 2: Title VI Program Policy Statement	4
SECTION 3: Title VI Complaint Procedures.....	5
SECTION 4: Public Participation Plan.....	7
SECTION 5: Limited English Proficiency	9
SECTION 6: Monitoring Subrecipients.....	11
SECTION 7: Analysis of Construction Projects	12
SECTION 8: System Wide Service Standards and Policies	12
SECTION 8: Galveston City Council Membership.....	15
SECTION 9: Safety & Security Committee Membership	15
SECTION 10: APPENDIX A.....	16

SECTION 1: Introduction

Galveston Island Transit began public transportation service in 1868 with two horse drawn trolleys on rail in the City of Galveston. Currently, Galveston Island Transit operates within the city limits of the City of Galveston and Galveston Island itself. Galveston Island Transit is a city department within the City of Galveston municipality and is a direct recipient of federal funding for public transportation. Galveston Island Transit offers public transit service including fixed route service, complementary ADA Paratransit Services, nostalgic tourist bus services and street rail trolley services.

Galveston Island Transit is submitting this report to the Federal Transit Administration, (FTA), providing a program to ensure that transit services made available are equitably distributed, and provide equal access and mobility to any person, without regard to race, color, or national origin. This program is updated every three (3) years and receives approval from FTA.

The program updated for 2025-2028 has been prepared pursuant to Title VI of the *Civil Rights Act of 1964*; Title 49, Chapter S3, Section S332 of the United States Code; and the FTA Circular 4702.IB, "Title VI Requirements and Guidelines for Federal Transit Administration Recipients," (October 1, 2012). Additionally, this update summarizes the Galveston Island Transit service provisions since the last program was approved. This update will provide compliance with all parameters of the FTA Title VI Program Checklist for all applicable requirements of Transit Providers.

The objectives of this Title VI Program include the following:

1. Ensure that federally assisted benefits and related services are made available and are equitably distributed.
2. Ensure that the level and quality of federally assisted services are sufficient to provide equal access and mobility to all persons.
3. Ensure adequate opportunities for all to participate in the planning and decision-making processes.
4. Ensure that placement of transit services and facilities are equitable.
5. Ensure that corrective and remedial actions are taken for all applications and receipts of federal assistance to prevent discriminatory treatment of any beneficiary.
6. Provide procedures for investigating Title VI complaints.
7. Take responsible steps for ensuring that meaningful access to programs and activities is provided for persons with Limited English Proficiency.

8. Inform the public of their rights under Title VI.

SECTION 2: Title VI Program Policy Statement

Title VI of the Civil Rights Act of 1964 prohibits discrimination on the basis of race, color, or national origin in programs and activities receiving Federal financial assistance. Specifically, Title VI provides that "no person in the United States shall, on the grounds of race, color, or national origin, be excluded from participation in, be denied the benefits of, or be subjected to discrimination under any program or activity receiving federal financial assistance.

The Environmental Justice (EJ) component of the Title VI requirements guarantees fair treatment for all people regardless of race and income. The requirements under EJ include Galveston Island Transit identifying and addressing, as appropriate, any potential disproportionate and/or adverse impact of its programs, policies, and activities on minority and low-income populations. In addition to EJ considerations in the administration of public transit, undertake reasonable steps to ensure that limited English Proficiency (LEP) persons have meaningful access to programs, services, and information.

The three fundamental Environmental Justice concepts are:

1. Avoid, minimize, or mitigate disproportionately high and adverse human health or environmental effects, including social and economic effects, on minority and low-income populations.
2. Ensure the full and fair participation by all potentially affected communities in the transportation decision-making process.
3. Prevent a denial, reduction, or significant delay in the receipt of benefits by minority and low-income populations.

The Public Transportation General Manager has been designated as the GIT Civil Rights Officer responsible for civil rights compliance and monitoring to ensure the nondiscriminatory provision of transit services and programs. To request a copy of the agency's Title VI program please contact:

Galveston Island Transit Title VI Contact:

James Oliver
Public Transportation General Manager
3115 Market Street, Galveston, Texas 77550
joliver@galvestontx.gov
409-797-3900

The Title VI Policy statement is disseminated to all staff and is also available on City of Galveston's website under: <https://www.galvestontx.gov/551/FTA-Civil-Rights-Discrimination-Notice>

The Title VI notice can be found on the City of Galveston's website, all transit terminals and on each bus and rail trolley. The Title VI notice will read as follows both in English and Spanish:

The City of Galveston hereby gives public notice that it is Galveston's policy to assure full compliance with Title VI of the Civil Rights Act of 1964, the Civil Rights Restoration Act of 1987, and related statutes and regulations in all programs and activities. Title VI requires that no person in the United States of America shall, on the grounds of race, color, or national origin, be excluded from the participation in, be denied the benefits of, or be otherwise subjected to discrimination under any program or activity receiving federal financial assistance.

Any person who believes they have been aggrieved by an unlawful discriminatory practice under Title VI has a right to file a formal complaint with Galveston. Any such complaint must be in writing or by phone and filed with Galveston Title VI Coordinator within one hundred and eighty (180) days following the date of the alleged discriminatory occurrence. Title VI Discrimination Complaint Forms may be obtained from the Island Transit administrative office at no cost to the complainant by calling 409-797-3900.

If you would like to file with the Federal Transit Administration (FTA) Regional Office, please send a written complaint to FTA Region VI, 819 Taylor Street, Room 8A36, Fort Worth, TX 76102. A complainant may also file a complaint directly with the FTA by filing a complaint with the Office of Civil Rights, Attention: Title VI Program Coordinator, East Building, 5th Floor-TCR, 1200 New Jersey Ave., SE, Washington, DC 20590.

If information is needed in another language, contact Galveston's Title VI Coordinator at 409-797-3900.

SECTION 3: Title VI Complaint Procedures

As a recipient of federal financial assistance, City of Galveston/Galveston Island Transit has the following Title VI complaint procedures in place.

Galveston Island Transit has provided procedures for filing complaints alleging discrimination on the basis of race, color, or national origin. Information on how to file a complaint is provided through Galveston Island Transit Administrative Offices, on City of Galveston website, and appears on publications, interior bus cards, and Galveston Island Transit facilities.

Any person who believes that he or she, individually or as a member of any specific class of persons, has been subjected to discrimination on the basis of race, color, or national origin may file a written complaint with Texas Department of Transportation (TxDOT), the FTA or the

Secretary of Transportation. Persons are encouraged to first notify Galveston Island Transit and file a complaint through the local office.

Galveston Island Transit
Atten: General Manager
3115 Market Street
Galveston, Texas 77550

Texas Department of Transportation
ATTN: Civil Rights Division
125 E. 11th Street
Austin, TX 78701

Federal Transit Administration (FTA)
Region VI
819 Taylor Street, Room 8A36
Fort Worth, Texas 76102

All complaints received within 180 days of the incident are processed and investigated by Galveston Island Transit. A preliminary review to determine jurisdiction is conducted and if within Galveston Island Transit authority and investigation is conducted. The complainant will receive an acknowledgement letter informing her/him whether the complaint and investigation.

Galveston Island Transit has 30 days to investigate the complaint. If more information is needed to resolve the case, Galveston Island Transit may contact the complainant. The complainant has 30 business days from the date of the letter to send requested information to the investigator. If the investigator is not contacted by the complainant or does not receive the additional information within 30 business days, Galveston Island Transit can administratively close the case. A case can also be administratively closed if the complainant no longer wishes to pursue their case.

After the investigator reviews the complaint, she/he will issue one of two letters to the complainant: a closure letter or a letter of finding (LOF). A closure letter summarizes the allegations and states that there was not a Title VI violation and that the case will be closed. An LOF summary that the allegations and the interviews regarding the alleged incident, and explains whether any disciplinary action, additional training of the staff member, or if any other action will occur. If the complainant wishes to appeal the decision, she/he has 30 days after the date of the letter or the LOF to do so.

A person may also file a complaint directly with the Federal Transit Administration, at FTA Office of Civil Rights, Attention: Title VI Program Coordinator, East Building, 5th Floor - TCR, 1200 New Jersey Ave., SE, Washington, DC 20590.

The Galveston Island Transit Title VI complaint form and associated procedures are available in English and Spanish in Appendix A of this plan as well as on the Galveston Island Transit website. If the information is needed in other languages spoken by LEP populations Galveston Island Transit will accommodate that request.

Title VI Complaints are documented and tracked for investigation and internal files have been reviewed to determine whether there were any complaints filed or concluded between submittal of the last Title VI Plan. There have been no Title VI complaints since the last update to the policy.

SECTION 4: Public Participation Plan

This document will serve as the Public Participation Plan for Galveston Island Transit. This Public Participation Plan outlines the process for providing the public and interested parties with reasonable opportunities to be involved in the transportation planning process.

The purpose of the Public Participation Plan is to ensure that Galveston Island Transit utilizes effective means of providing information and receiving public input on transportation decisions from all citizens including low income, minority and limited English proficient (LEP) populations, as required by Title VI of the Civil Rights Act of 1964 and its implementing regulations. Under federal regulations, transit operators must take reasonable steps to ensure that Limited English Proficient (LEP) persons have meaningful access to their programs and activities. This means that public participation opportunities, normally provided in English, should be accessible to persons who have a limited ability to speak, read, write, or understand English.

Galveston Island Transit is the public transportation provider for the City of Galveston, GIT service area includes Galveston Island and City of Galveston. The service area 41square miles of land with a population of 53,800 according to American Community Survey of 2020. The demographics of the population shows that 61.4% is white, 14.6% African American, 29.7% Latin/Hispanic and 17.4% two or more races.

Galveston City, Texas

White alone	33,033
Black or African American alone	7854
American Indian and Alaska Native alone	322
Asian alone	1506
Native Hawaiian and Other Pacific Islander alone	53
Hispanic or Latino	15,978
Population of two races	9,361

Further analysis of the American Community Surveys reveals the poverty level of the population of the City of Galveston as it relates to the environmental justice aspect of the overall Title VI policy.

Label	Galveston city, Texas					
	Total		Below poverty level		Percent below poverty level	
	Estimate	Margin of Error	Estimate	Margin of Error	Estimate	Margin of Error
White alone	30,632	±1,094	4,623	±701	15.1%	±2.2
Black or African American alone	7,114	±834	1,732	±410	24.3%	±5.1
American Indian and Alaska Native alone	260	±155	47	±37	18.1%	±16.7
Asian alone	1,398	±377	459	±174	32.8%	±9.3
Native Hawaiian and Other Pacific Islander alone	67	±73	39	±63	58.2%	±58.2
Some other race alone	1,621	±338	475	±208	29.3%	±11.9
Two or more races	8,782	±1,071	2,543	±733	29.0%	±7.0
Hispanic or Latino origin (of any race)	14,972	±968	4,365	±884	29.2%	±5.3
White alone, not Hispanic or Latino	25,249	±1,069	3,124	±502	12.4%	±1.8

Galveston is considered a tourist destination and experiences seasonal changes, as such growth opportunities are limited. Galveston Island Transit does not experience the need for many changes of its fixed route, tourist routes or changes within the rate structure.

Throughout the year, Galveston Island Transit welcomes comments by riders and other members of the public. Comments are recorded and accumulated for consideration at the time of the development of draft proposals for change or system improvements. Comments related to service changes including requests for new route or other services are accumulated for consideration in planning activities.

Galveston Island Transit maintains a public participation process for all transportation planning and or transit construction projects. The process is two-fold in that, GIT utilizes the regional MPO, Houston- Galveston Area Council (H-GAC), as well as the Public Works and Planning Departments within the City of Galveston to also include Galveston City Council. Galveston Island Transit as part of the rail trolley operations is required by TxDOT Program Standards to have a Joint Safety & Security Review Committee to review and approve items that come before the committee for the rail trolleys.

Galveston Island Transit conducts a public hearing/meeting when a fare increases, or major service reduction is proposed. "Major service reduction is defined as a reduction which reduces service hours and/or service miles by 25% on any individual route." A determination is made related to each proposed change as to the appropriate timing on the public hearing. If service changes are temporary in nature for evaluation for the proposal, the hearing will be held after the pilot period and the evaluation is completed. For changes in fares or significant service changes, the hearing will be held prior to initiation of action. If the service changes or schedule modifications are deemed to be minor, the changes can go forward without City Council action and GIT may implement.

Galveston Island Transit staff develop draft proposals for changes in services or fare based upon consideration of public comment, City policy and other directions. Recommendations are provided to the City leadership for evaluation, consideration and revisions if necessary. The revised drafts are identified within the City's Budget process. The City's multi-staged budget development process includes public workshops and formal public hearings prior to Galveston City Council approval.

City Council meetings are open to the public and informational material is provided and can be provided in Spanish upon request as noted on the public notices for each council meeting. City of Galveston and GIT utilize multiple media outlets to give public notice of committee meetings, transportation projects and transportation funding opportunities. Those outlets would include newspapers, website, television and social media.

Galveston Island Transit annually updates future transportation improvement programs, projects and transportation funding. Galveston Island Transit coordinates these updates/notifications through the H-GAC MPO as well as city departments within the City of Galveston. Galveston Island Transit goal for public participation is to offer early and continuous opportunities for the public to be involved in the identification of social, economic and environmental impacts of proposed transportation projects, decisions.

SECTION 5: Limited English Proficiency

Executive Order 13166, Improving Access to Services for Persons with Limited English Proficiency (LEP), was signed by President Clinton in August 2000. The Executive Order directs each federal agency to examine the services it provides and develop and implement a system by which LEP persons can meaningfully access those services. Failure to ensure opportunities for LEP persons to effectively participate in or benefit from federally assisted programs may constitute national origin discrimination.

As a public transportation provider receiving federal funding from the U.S. Department of Transportation (DOT), Galveston Island Transit has a responsibility, under Title VI of the Civil Rights Act of 1964, to take reasonable steps to ensure that LEP persons have meaningful access to benefits, services, information, and other Important programs and activities provided by Galveston Island Transit. LEP persons include individuals who have a limited ability to read, write, speak, or understand English. Many LEP persons rely on public transit services to achieve greater mobility and access to employment. The DOT developed LEP guidance to assist public transit agencies in determining the best ways to comply with the statutory and regulatory LEP obligations. Transit agencies should conduct an LEP needs assessment based on the four-factor framework.

The four-factor framework includes four steps that assist transit agencies in developing a cost-effective mix of language assistance measures. The factors that should be considered during the LEP needs assessment include:

1. The number and proportion of LEP persons served or encountered in the eligible service population.

2. The frequency with which LEP persons come into contact with the agency's programs, activities, and services.
3. The Importance of the programs, activities, and services to LEP persons; and
4. The Cost and resources available.

Factor 1

LEP individuals will come into contact with Galveston Island Transit through various means, utilizing fixed routes services by accessing and riding fixed route, through the rail trolley system by the same means and the Seawall Tourist route, again by the same means. LEP individuals will also come into contact with Galveston Island Transit through contacting and scheduling service through Complementary ADA Paratransit Services as well as other transportation projects such as construction, pedestrian, rail and bus stop projects.

According to the American Community Survey 2020 data, 26% of the residents of City of Galveston speak other language than English at home. 19.7% of the respondents speak Spanish at home.

Galveston city, Texas				
Language	Total		Percent	
	Estimate	Margin of Error	Estimate	Margin of Error
Speak only English	37,732	±1,045	74.1%	±1.8
Speak a language other than English	13,214	±888	25.9%	±1.8
Spanish	10,049	±848	19.7%	±1.7
Other Indo-European languages	1,776	±413	3.5%	±0.8
Asian and Pacific Island languages	1,046	±307	2.1%	±0.6
Other languages	343	±157	0.7%	±0.3

Galveston Island Transit does not monitor the literacy rates of LEP populations. However, Galveston Island Transit translates both written and orally, all notifications, schedules, public communications into Spanish. Currently, Galveston Island Transit monitors and tracks requests to translate information orally. Galveston Island Transit is not aware or knows of any other languages barriers that exist that would prevent an LEP individual accessing or learning of Galveston Island Transit and the services provided.

Factor 2

Galveston Island Transit utilizes FTA funding to provide public transportation services and develop transit infrastructure that facilitates access to public transportation services. Galveston Island Transit LEP individuals will come into contact with public transportation through accessing transportation services, transit terminals, bus stops and other transportation projects. Galveston Island Transit is committed to during all public involvement that all documentation for transit programs, procurements, schedules advertising and other transit documents can be translated into Spanish at no cost to the user. Currently, all route closures/deviations, ADA forms, Title VI forms, schedules and public notifications are translated into Spanish.

Factor 3

Galveston Island Transit will continue to train and develop staff members on the importance of assisting LEP individuals with obtaining information and accessing the transit system. Staff will be provided with LEP procedures, in addition Staff will complete customer service training and be provided guidance on working effectively with in-person and telephone interpreters. GIT will continue to post communications in Spanish and will also inform of additional language services available at the customer initial point of contact. Galveston Island Transit will participate in the annual updates to the H-GAC MPO planning activities as well with the City of Galveston planning activities to also include the City's evacuation and disaster preparedness plans to ensure all community members' needs are met, especially including the LEP population.

Factor 4

Based upon the current resources available, Galveston Island Transit provides the most effective means of delivering competent and accurate language services within the service area. GIT will continue to monitor the need for additional language assistance, including the need for greater dissemination of information in the existing languages provided and/or translation to new languages.

SECTION 6: Monitoring Subrecipients

Galveston Island Transit currently contracts with Harris County Rides to provide ADA Complementary Paratransit Services for those clients that are eligible on Galveston Island. In accordance with 49 CFR 21.9(b), to ensure that subrecipients are complying with DOT Title VI regulations, primary recipients must monitor their subrecipients for compliance with the regulations. If a subrecipient is not in compliance with the regulations, the primary recipient is also not in compliance.

FTA Circular 4702 1.b, Chapter III section 12b states as follows: "*When a subrecipient is also a direct recipient of FTA funds, that is, applies for funds directly from FTA, in addition to receiving funds from the primary recipient, the subrecipient/ direct recipient reports directly to FTA and the*

primary/designated recipient is not responsible for monitoring compliance if that subrecipient. Harris County Rides applies/receives funding direct from FTA, as Galveston Island Transit is exempted from the responsibility of monitoring the Title VI activities of Harris County Rides. However, GIT does have a copy of Harris County Rides Title VI policy

SECTION 7: Analysis of Construction Projects

Galveston Island Transit has not had any construction projects during this time period.

SECTION 8: System Wide Service Standards and Policies

CFR 49, Part 21 requires all providers of fixed route public transportation that receive federal financial assistance adopt system wide service policies to ensure service design and operation practices do not result in discrimination on the basis of race, color or national origin. Service policies differ from standards in that they are not necessarily based upon a quantitative standard. All fixed route transit providers shall set service standards and policies for each specific fixed route mode of service that is provided. Galveston Island Transit has three modes of fixed route service, fixed route bus service, Seawall tourist routes and light-rail/trolley service.

FTA requires all fixed route providers to develop quantitative standards for all fixed route modes of operation for the following indicators.

1. Vehicle Load
 2. Vehicle Headway
 3. On-Time Performance for each mode
 4. Service Availability for each mode
-
1. Vehicle Load: Vehicle load is expressed as the ratio of passengers to the total number of seats available on a vehicle at its maximum load point. The standard for maximum vehicle load is 1.00. Galveston Island Transit is currently operating below the maximum load for each mode.

VEHICLE LOAD

	MAXIMUM LOAD	CURRENT OPERATING CAPACITY
FIXED ROUTE BUSES	24	33%
SEAWALL TOURIST ROUTE	24	33%
GALVESTON ISLAND TROLLEY	20	31%

2. **Vehicle Head:** Vehicle headway is the amount of time a vehicle needs to return to the same point while on a route. A shorter headway corresponds to a more frequent service. Below are the following headways set by Galveston Island Transit for the current fixed route modes. Galveston Island Transit currently meets the headways that are listed below.

VEHICLE HEADWAYS

FIXED ROUTE	60 MINUTES
SEAWALL TOURIST ROUTE	30 MINUTES
GALVESTON ISLAND TROLLEY	30 MINUTES

3. **On-Time Performance:** On-Time Performance is a measure of runs completed as scheduled and published. The criterion first must define what is considered to be "on-time". The standard for Galveston Island Transit on-time performance is no more or less 4 minutes before or after the published stop. Galveston Island Transit began tracking on-time performance in Fall of 2020. Currently, GIT has established and 85% percentage of on time runs to begin the initial tracking of on time performance. Galveston Island Transit is currently meeting this standard.

4. **Service Availability for each mode:** Service Availability is the general measure of the distribution of routes within a provider's service area. The standard for service availability is to provide coverage of the primary destinations; (to include healthcare, tourist, medical and senior housing facilities), within Galveston Island Transit service area of operations as recommended by the public through public participation and as directed by City Council.

Galveston Island Transit Service Policies ensure that operational practices do not discriminate on the basis of race, color or national origin.

1. **Transit Amenities:** Transit amenities are reference to items of comfort, convenience and safety that are available to the general riding public. Amenities would include the following:
 - Bus and Rail Shelters (benches, seats at stops and stations)
 - Provision Information
 - Printed signs, system maps, route maps, and schedules
 - Elevators
 - Access points include the transit station and transfer station.

Galveston Island Transit has a policy to ensure the equitable distribution of transit amenities across system wide.

2. **Vehicle Assignment:** Vehicle assignment refers to the process by which transit vehicles are placed into revenue service and on routes throughout the system. Vehicles are assigned with regard to mode (Fixed, Seawall Tourist, Rail Trolley) and ridership demand patterns. For each mode, newer vehicles are rotated to ensure that no single route or service always has the same vehicle. The rotation process is reviewed weekly by the Transit Supervisor, Maintenance Supervisor and Assistant General Manager of Galveston Island Transit.

SECTION 8: Galveston City Council Membership

	White/Non Latino	Black/African American	Latino/Hispanic	American Indian/Alaska Native	Asian American	Pacific Islander	Other
City Council Members	6	1	0	0	0	0	0

SECTION 9: Safety & Security Committee Membership

	White/Non Latino	Black/African American	Latino/Hispanic	American Indian/Alaska Native	Asian American	Pacific Islander	Other
Committee Members	5	0	3	0	0	0	0

- *Committee members are City of Galveston employees from respective departments within the City of Galveston, ie. Galveston Police Department, Galveston Fire Department, Galveston Public Works, Traffic Division, Galveston Risk Management.*

SECTION 10: APPENDIX A



TITLE VI POLICY STATEMENT

Galveston Island Transit (Island Transit) is committed to ensuring that no person is excluded from participation in or denied the benefits of its services on the basis of race, color, or national origin, as provided by TITLE VI of the Civil Rights Act of 1964, as amended.

Toward this end, it is Galveston Island Transit's objective to:

- 1. Ensure that the level and quality of transportation service is provided without regard to races, color or national origin.**
- 2. Identify and address as appropriate, disproportionately high and adverse human health and environmental effects, including social and economic effects of programs and activities on minority populations and low-income populations.**
- 3. Promote the full and fair participation of all affected populations in transportation decision making.**
- 4. Prevent the denial, reduction or delay in benefits related to programs and activities that benefit minority populations or low-income populations.**
- 5. Ensure meaningful access to programs and activities by person with Limited English Proficiency (LEP).**
- 6. Provide customers language assistance, at no cost.**

The Public Transportation General Manager, and all employees at Galveston Island Transit share the responsibility for carrying out Galveston Island Transit commitment to TITLE VI. The Title VI staff is responsible for the day to day operation of the program, and receives and investigates Title VI complaints that come through the complaint procedures process.

For additional information on Galveston Island Transit nondiscrimination obligations, please contact:

General Manager
c/o Galveston Island Transit
3115 Market St
Galveston Texas, 77550
Phone: 4009-797-3900
Email: joliver@galvestontx.gov



TÍTULO VI DECLARACIÓN DE POLÍTICA

Galveston Island Transit (Island Transit) se compromete a garantizar que ninguna persona sea excluida de la participación o se le nieguen los beneficios de sus servicios por motivos de raza, color o origen nacional, según lo dispuesto por el TÍTULO VI de la Ley de Derechos Civiles de 1964, según enmendada.

Con este fin, el objetivo de Galveston Island Transit es:

- 1. Asegurarse de que el nivel la calidad del servicio de transporte se brinde sin importar razas, color o origen nacional.**
- 2. Identificar y abordar, según corresponda, los efectos desproporcionadamente altos y adversos para la salud humana y el medio ambiente, incluidos los efectos sociales y económicos de los programas y actividades en las poblaciones minoritarias y de bajos ingresos.**
- 3. Promover la participación plena y justa de todas las poblaciones afectadas en la toma de decisiones sobre transporte.**
- 4. Prevenir la denegación, reducción o demora en los beneficios relacionados con programas y actividades que benefician a las poblaciones minoritarias o de bajos ingresos.**
- 5. Asegurar un acceso significativo a los programas y actividades por parte de una persona con dominio limitado del inglés (LEP).**
- 6. Brindar a los clientes asistencia con el idioma, sin costo alguno.**

El Gerente General de Transporte Público y todos los empleados de Galveston Island Transit comparten la responsabilidad de llevar a cabo el compromiso de Galveston Island Transit con el TÍTULO VI. El personal del Título VI es responsable de la operación diaria del programa y recibe y investiga las quejas del Título VI que surgen a través del proceso de procedimientos de quejas.

Para obtener información adicional sobre las obligaciones de no discriminación de Galveston Island Transit, comuníquese con:

Gerente general
c / o Galveston Island Transit
3115 Market St
Galveston Texas, 77550
Teléfono: 4009-797-3900
Correo electrónico: joliver@galvestontx.gov

TITLE VI COMPLAINT FORM

Galveston Island Transit is committed to a policy of non-discrimination in the conduct of its business, including Title VI responsibilities, and to the delivery of equitable and accessible transportation services. Any person who believes that he or she has been subject to discrimination under Title VI on the basis of race, color or national origin may file a Title VI complaint with Galveston Island Transit within 180-days from the date of the alleged discrimination.

Section I:				
Name:				
Address:				
Telephone (Home):			Telephone (Work):	
Electronic Mail Address:				
Accessible Format Requirements?	Large Print		Audio Tape	
	TDD		Other	
Section II:				
Are you filing this complaint on your own behalf?			Yes*	No
*If you answered "yes" to this question, go to Section III.				
If not, please supply the name and relationship of the person for whom you are complaining:				
Please explain why you have filed for a third party:				
Please confirm that you have obtained the permission of the aggrieved party if you are filing on behalf of a third party.			Yes	No
Section III:				
I believe the discrimination I experienced was based on (check all that apply):				
<input type="checkbox"/> Race <input type="checkbox"/> Color <input type="checkbox"/> National Origin				
Date of Alleged Discrimination (Month, Day, Year): _____				
Explain as clearly as possible what happened and why you believe you were discriminated against. Describe all persons who were involved. Include the name and contact information of the person(s) who discriminated against you (if known) as well as names and contact information of any witnesses. If more space is needed, please use the back of this form.				
Section IV				
Have you previously filed a Title VI complaint with this agency?			Yes	No
Section V				
Have you filed this complaint with any other Federal, State, or local agency, or with any Federal or State court?				
<input type="checkbox"/> Yes <input type="checkbox"/> No				
If yes, check all that apply:				

TITLE VI COMPLAINT FORM

<input type="checkbox"/> Federal Agency: _____	
<input type="checkbox"/> Federal Court _____	<input type="checkbox"/> State Agency _____
<input type="checkbox"/> State Court _____	<input type="checkbox"/> Local Agency _____
Please provide information about a contact person at the agency/court where the complaint was filed.	
Name:	
Title:	
Agency:	
Address:	
Telephone:	
Section VI	
Name of agency complaint is against:	
Contact person:	
Title:	
Telephone number:	

You may attach any written materials or other information that you think is relevant to your complaint.

Signature and date required below

Signature

Date

Please submit this form in person at the address below, or mail this form to:

Galveston Island Transit
c/o Public Transportation General Manager
3115 Market St.
Galveston, Texas 77550
(409)-797-3900
joliver@galvestontx.gov



Galveston Island Transit está comprometido con una política de no discriminación en la conducta de sus negocios, incluidas las responsabilidades del Título VI, y con la prestación de servicios de transporte equitativos y accesibles. Cualquier persona que crea que ha sido objeto de discriminación bajo el Título VI por motivos de raza, color u origen nacional puede presentar una queja de Título VO ante Galveston Island Transit dentro de los 180 días a partir de la fecha de la presunta discriminación.

Sección I:				
Nombre:				
Dirección:				
Teléfono (Inicio):			Teléfono (Trabajo):	
Dirección de correo electrónico:				
¿Requisitos de formato accesible?	Letra grande		Cinta de audio	
	TDD		Otro	
Sección II:				
¿Está presentando esta queja en su propio nombre?			Sí*	No
*Si respondió "sí" a esta pregunta, vaya a la Sección III.				
De lo contrario, proporcione el nombre y la relación de la persona por la que se queja:				
Por favor, explique por qué ha solicitado a un tercero: _____				
Confirme que ha obtenido el permiso de la parte agraviada si está presentando una solicitud en nombre de un tercero.			Sí	No
Sección III:				
Creo que la discriminación que experimenté se basó en (verifique todo lo que se aplica):				
[] Raza [] Color [] Origen nacional				
Fecha de la presunta discriminación (mes, día, año): _____				
Explique lo más claramente posible lo que sucedió y por qué cree que fue discriminado. Describa a todas las personas que estuvieron involucradas. Incluya el nombre y la información de contacto de la(s) persona(s) que lo discriminó (si se conoce), así como los nombres y la información de contacto de cualquier testigo. Si se necesita más espacio, utilice la parte posterior de este formulario.				

Sección IV				
¿Ha presentado previamente una queja del Título VI ante esta agencia?			Sí	No
Sección V				
¿Ha presentado esta queja ante alguna otra agencia federal, estatal o local, o ante algún tribunal federal o estatal?				
[] Sí [] No				

En caso afirmativo, marque todo lo que corresponda: <input type="checkbox"/> Agencia Federal: _____ <input type="checkbox"/> Tribunal Federal <input type="checkbox"/> Agencia Estatal _____ <input type="checkbox"/> Tribunal Estatal <input type="checkbox"/> Agencia Local _____
Proporcione información sobre una persona de contacto en la agencia / tribunal donde se presentó la queja.
Nombre:
Título:
Agencia:
Dirección:
Teléfono:
Sección VI
El nombre de la queja de la agencia es contra:
Persona de contacto:
Título:
Número de teléfono:

Puede adjuntar cualquier material escrito o otra información que considere relevante para su queja.

Firma y fecha requeridas a continuación

Signature Date

Envíe este formulario en persona a la dirección que aparece a continuación, o envíelo por correo a:

Tránsito de la isla de Galveston
c/o Gerente General de Transporte Público
3115 Market St.
77550, Galveston, Texas
(409)-797-3900
joliver@galvestontx.gov





City of Galveston

FLEET, MASS TRANSIT & SPECIAL EVENTS STAFF REPORT

Date February 18, 2025

To: City Manager
Mayor and City Council Members

From: David Smith, Executive Director
Fleet, Mass Transit and Special Events

Project location: N/A

Project: EMS Agreement - Mardi Gras 2025

Request: Consider for the approval of the agreement for the payment to the Galveston County Health District (EMS) for emergency medical services that will be provided during the 2025 Mardi Gras event for a total of \$23,408 and authorize the City Managers staff to execute the document upon final approval by the City Attorney.

Prior Council Action

None

Background

- A. The Galveston County Health District provides emergency medical services within the venue for the attendees as well as the staff during the two-week Mardi Gras event period.
- B. The EMS estimation for the coverage for the 2025 event is \$23,408.
- C. A breakdown of the labor hours is listed in the GCHD attachment below.
- D. These services are provided within the entertainment venue.

Fiscal Impact Report





City of Galveston

FLEET, MASS TRANSIT & SPECIAL EVENTS STAFF REPORT

Description	Funding	Est Price
Emergency Medical Service	Mardi Gras Special Revenue Fund - Convention Center Surplus Fund	\$23,408.00

Alternatives

A. Approve.

1. Cost - \$23,408
2. Timing - As soon as possible.
3. Departmental Improvements - Will allow EMS to provide medical services during the Mardi Gras event.

B. Do not approve.

1. Cost - None
2. Timing - N/A
3. Departmental Improvements - None - volunteers would have to be located to provide medical services.

Staff Recommendation

Concur in Alternative A; approve the agreement for the payment to the Galveston County Health District (EMS) for emergency medical services that will be provided during the 2025 Mardi Gras event for a total of \$23,408 and authorize the City Managers staff to execute the document upon final approval by the City Attorney.

Attachments



GALVESTON COUNTY HEALTH DISTRICT

Protecting and promoting the One Health of Galveston County.

Philip Keiser, MD
Local Health Authority
Chief Executive Officer



Della Brown, RN
Chief Operating Officer

February 17, 2025

Brian Maxwell
City Manager, City of Galveston
2222 28th Street
Galveston, TX 75550

Dear Brian,

This is a Letter Agreement for the **Galveston Area Ambulance Authority** to provide an ambulance during the **Mardi Gras event scheduled for February 21-23 and February 28 - March 2, 2025.**

We have determined the **estimated** cost to provide the service will be **\$23,408** (92 hours @ \$165 per hour and 68 hours @ \$121 per hour). The final invoice will be sent to you by our accounting department at the Galveston County Health District, which will reflect the actual hours worked by our staff. Payment will be due within thirty (**30**) days from the date in which the City of Galveston receives the invoice.

If you and/or the entity you represent agree with these terms and conditions, please sign the area indicated below and either mail or fax (409) 765-2503 a signed copy back to our office.

Should you have questions pertaining to this Agreement, please contact Amy Weber (409) 938-2345 or aweber@gchd.org.

Sincerely,

A handwritten signature in black ink, appearing to be "Cable", written over a horizontal line.

GAAA Representative
(Signature)

A handwritten signature in black ink that reads "Ruthie Cable", written over a horizontal line.

GCHD CFO
(Signature)

By my signature, I hereby agree to the above stated terms and agree to remit payment as requested.

Authorized Representative/Agent
(Please Print)

Authorized Representative/Agent
(Signature)

Mardi Gras 2025

Date	Time	Total Hours	Unit #	Location	Rate/Hour	Total
2/21/2025	1600-0000	8	Medic 20	25th and Strand	\$165	\$1,320
	1600-0000	8	Medic 21	19th and Mechanic	\$165	\$1,320
	1700-0000	7	Event Supervisor	25th and Strand	\$121	\$847
	1700-0000	7	EOC Representative	Galveston EOC	\$121	\$847
2/22/2025	1100-0000	13	Medic 20	25th and Strand	\$165	\$2,145
	1300-0000	11	Medic 21	19th and Mechanic	\$165	\$1,815
	1100-0000	13	Event Supervisor	25th and Strand	\$121	\$1,573
	1700-0000	7	EOC Representative	Galveston EOC	\$121	\$847
2/23/2025	1100-1700	6	Medic 20	25th and Strand	\$165	\$990
2/28/2025	1600-0000	8	Medic 20	25th and Strand	\$165	\$1,320
	1600-0000	8	Medic 21	19th and Mechanic	\$165	\$1,320
	1700-0000	7	Event Supervisor	25th and Strand	\$121	\$847
	1700-0000	7	EOC Representative	Galveston EOC	\$121	\$847
3/1/2025	1100-0000	13	Medic 20	25th and Strand	\$165	\$2,145
	1300-0000	11	Medic 21	19th and Mechanic	\$165	\$1,815
	1100-0000	13	Event Supervisor	25th and Strand	\$121	\$1,573
	1700-0000	7	EOC Representative	Galveston EOC	\$121	\$847
3/2/2025	1100-1700	6	Medic 20	25th and Strand	\$165	\$990

\$23,408



City of Galveston

FLEET, MASS TRANSIT & SPECIAL EVENTS STAFF REPORT

Date February 18, 2025

To: City Manager
Mayor and City Council Members

From: David Smith, Executive Director
Fleet, Mass Transit and Special Events

Project location: N/A

Project: New Spartan Fire Pumper Purchase

Request: Consider for the approval of the purchase of one new Spartan fire pumper for the Fire Department to be purchased from Metro Fire Apparatus Specialists Inc. through Sourcewell Coop for a total extended price of \$1,128,886.27 and authorize the City Manager to execute the contract upon final approval by the City Attorney.

Prior Council Action

No prior actions on this subject.

Background

- A. Funding for new equipment has been earmarked for the listed department. The pumper that is under consideration is a Spartan ERV002 ERV Legend Top Mount Pumper, Metro Star Chassis, Single Axle, 750 Gallon Tank with a 1,500 GPM pump.
- B. Sourcewell, HGAC Buy, and TXMAS are cooperative purchasing organizations that the city is a member of that performs bidding packages for local governments on small and large equipment.
- C. The total package price from Metro Fire Apparatus Specialists Inc. through Sourcewell is \$1,128,886.27. Contract item 113021-RVG-4.
- D. Metro has met with city staff and advised that if a first payment of \$50,000 is made, the final price of \$1,128,886.27 will be locked. The second remaining amount of \$1,078,886.27 will be charged upon receiving the new pumper.





City of Galveston

FLEET, MASS TRANSIT & SPECIAL EVENTS STAFF REPORT

- E. The specifications for this pumper match the Galveston Fire Departments and the Fleet Facility specifications. Delivery periods for new pumpers can extend to two years.
- F. Metro Fire Apparatus Specialists Inc. is based out of Houston, Texas. The factory which will build the truck, is in Brandon, South Dakota. The estimated delivery should occur in 2026.
- G. The new pumper will replace an older pumper that has been flagged for replacement by the Vehicle Replacement Program.

Fiscal Impact Report

Count	Unit	Assignment	Delivery - Calendar Year	Extended \$
1	ERV002 Spartan Pumper	Fire Suppression	1st QT 2026	\$1,128,886.27
Down Payment	Fire Special Revenue Fund	\$ 50,000.00		
Final Payment	Budget FY 2025-26 Capital	\$ 1,078,886.27		
		\$ 1,128,886.27		

Alternatives

- A. Approve the purchase:
 - 1. Cost – First payment of \$50,000, second payment of \$1,078,886.27 upon delivery
 - 2. Timing - Estimated delivery date is early 2026.
 - 3. Departmental Improvements - Will provide the Fire Department with the equipment needed to perform duties. Newer equipment will reduce fleet maintenance dollars.
- B. Do not approve the purchase:
 - 1. Cost - No additional cost at this time.
 - 2. Timing - N/A
 - 3. Departmental Improvements - The Fire Department will not be able to function at their fullest extent without needed equipment. Older equipment will take on a heavier load, which will increase maintenance dollars.





City of Galveston

FLEET, MASS TRANSIT & SPECIAL EVENTS STAFF REPORT

Staff Recommendation

Concur in Alternative A and approve allowing the purchase of one new Spartan fire pumper for the Fire Department to be purchased from Metro Fire Apparatus Specialists Inc. through Sourcewell Coop for a total extended price of \$1,128,886.27 and authorize the City Manager to execute the contract upon final approval by the City Attorney.

Attachments





Vendor Contract #113021-RVG-4

February 19, 2025

City of Galveston (Fire Department)
Member ID #173100
823 26th Street
Galveston, TX 77553

We are pleased to offer to you a ERV002 ERV Legend Top Mount Pumper, Metro Star Chassis, Single Axle, 750 Gal Tank, 1500 GPM Pump through the Sourcewell® Contract, based on the provided specifications and drawings.

MSRP	\$1,128,886.27
Sourcewell Discount	(-\$104,234.27)
Discount Percentage	9.23%
Down Payment	(-\$50,000.00)
Total Contract Price	\$1,024,652.00

Prices above do not include any Federal, State or local taxes.

We look forward to providing your agency with an industry leading apparatus. Our legacy of expertise means we build your apparatus from the ground up on a foundation ready to handle your specific response equipment and route needs. We strategically configure your apparatus design to represent the best possible mix of safety, speed, agility, ergonomics, and serviceability.





COMPARTMENT	VOLUME (CUBIC FEET)
L1	29.4
L2	27.3
L3	36.4
R1	29.4
R2	27.3
R3	36.4
BI	31.9
HOSE BED AREA	150.1

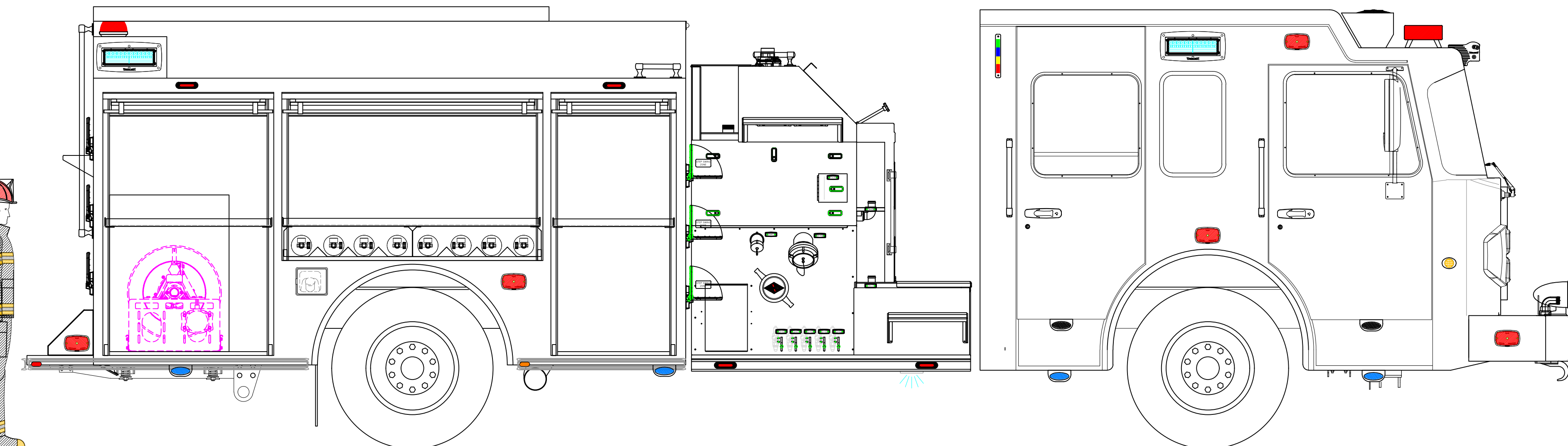
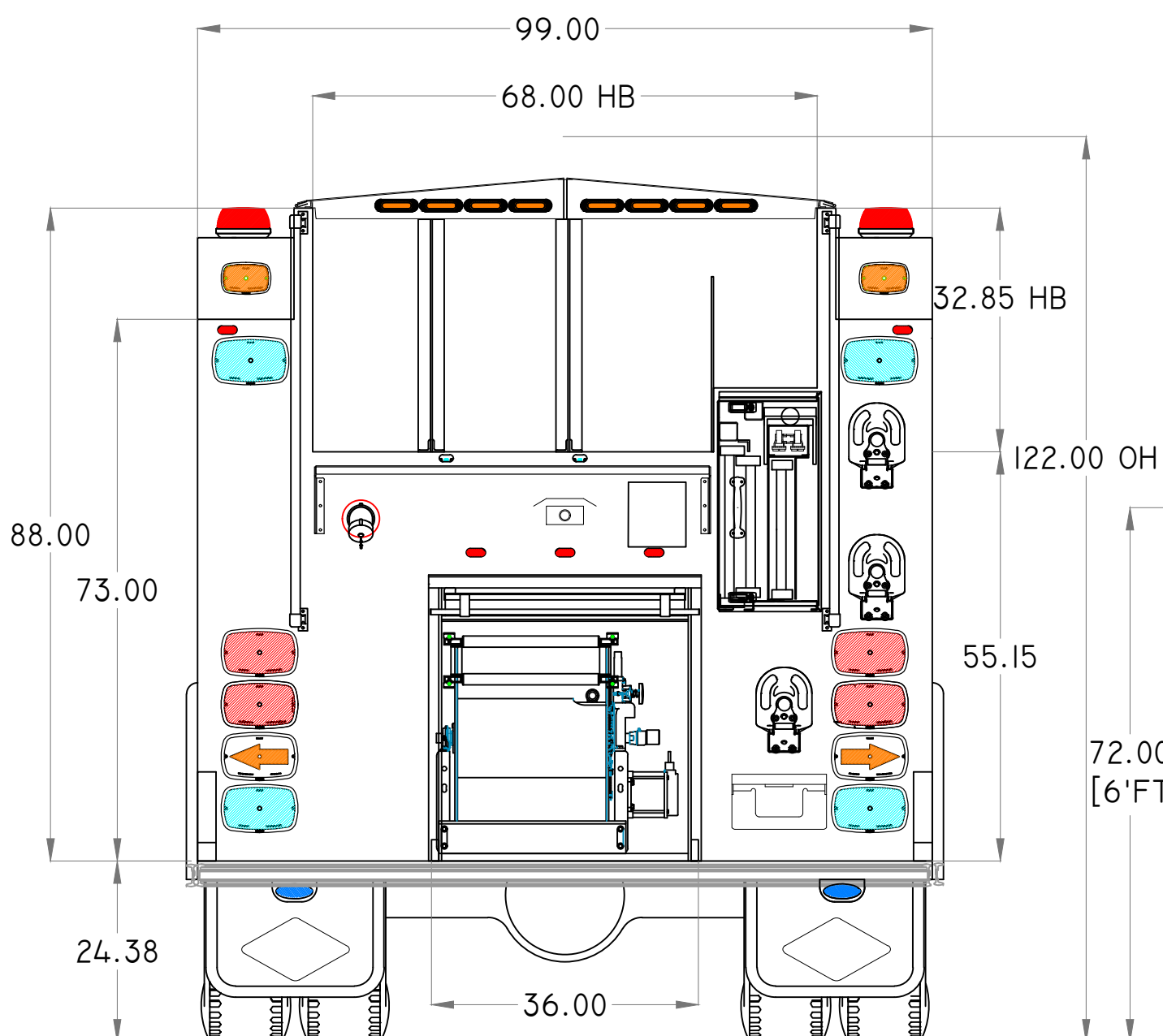
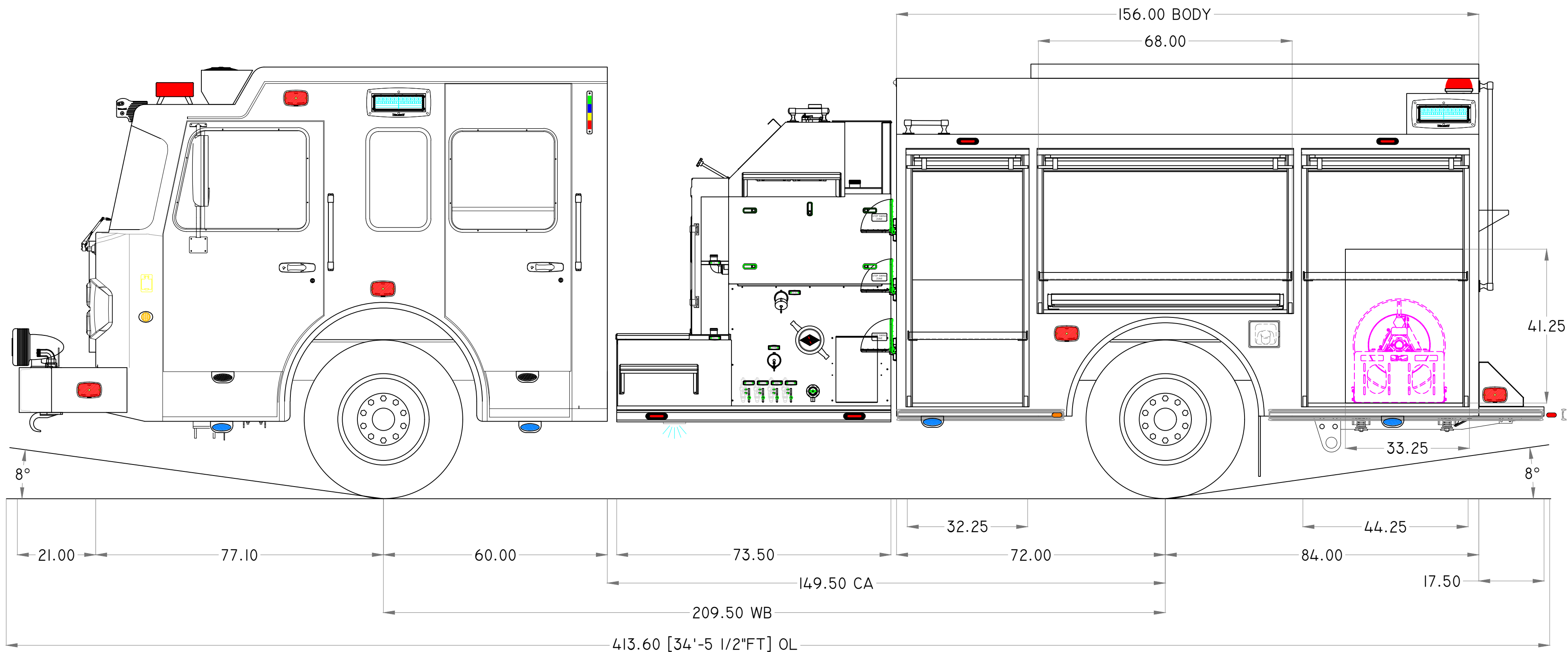
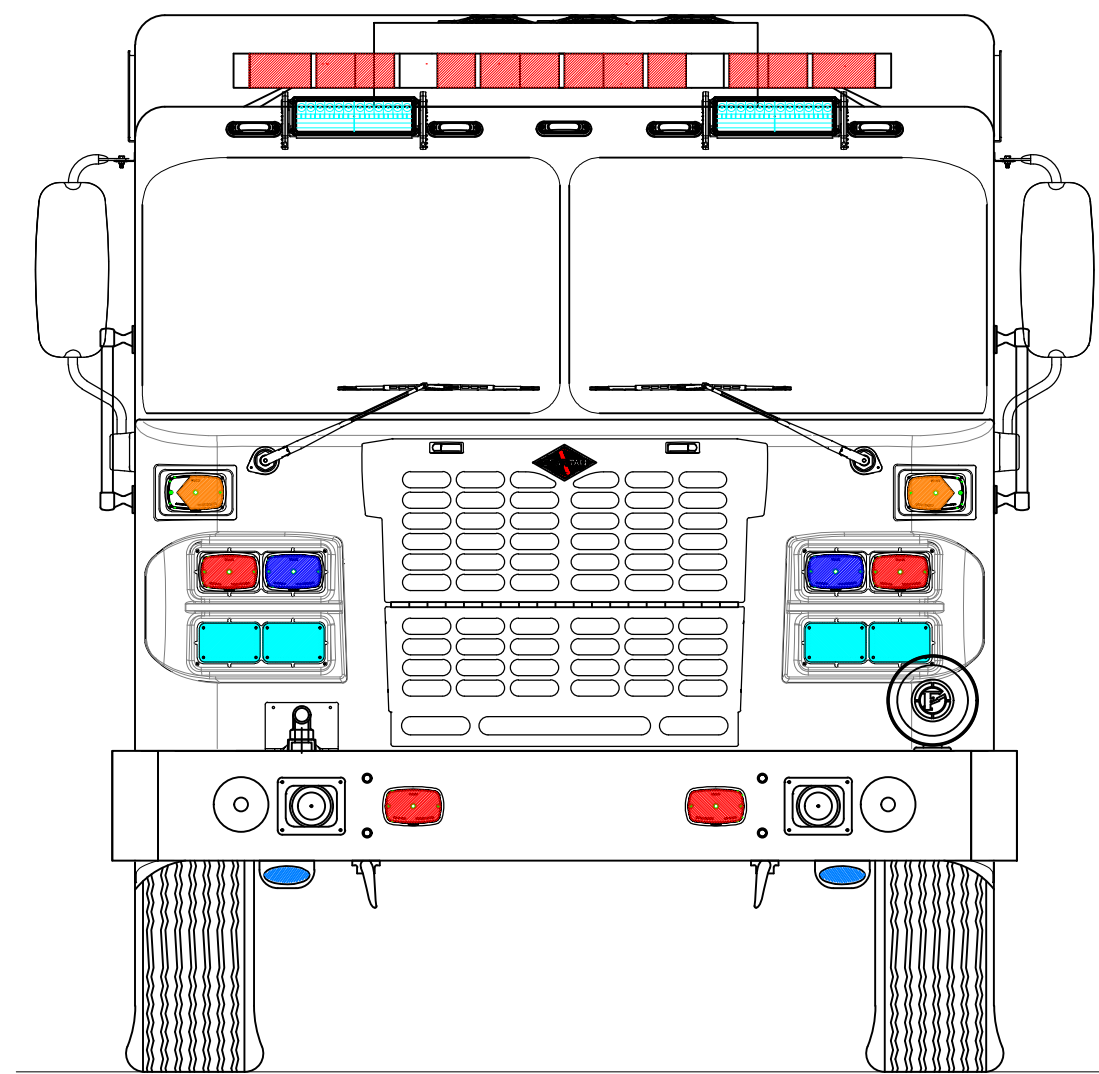
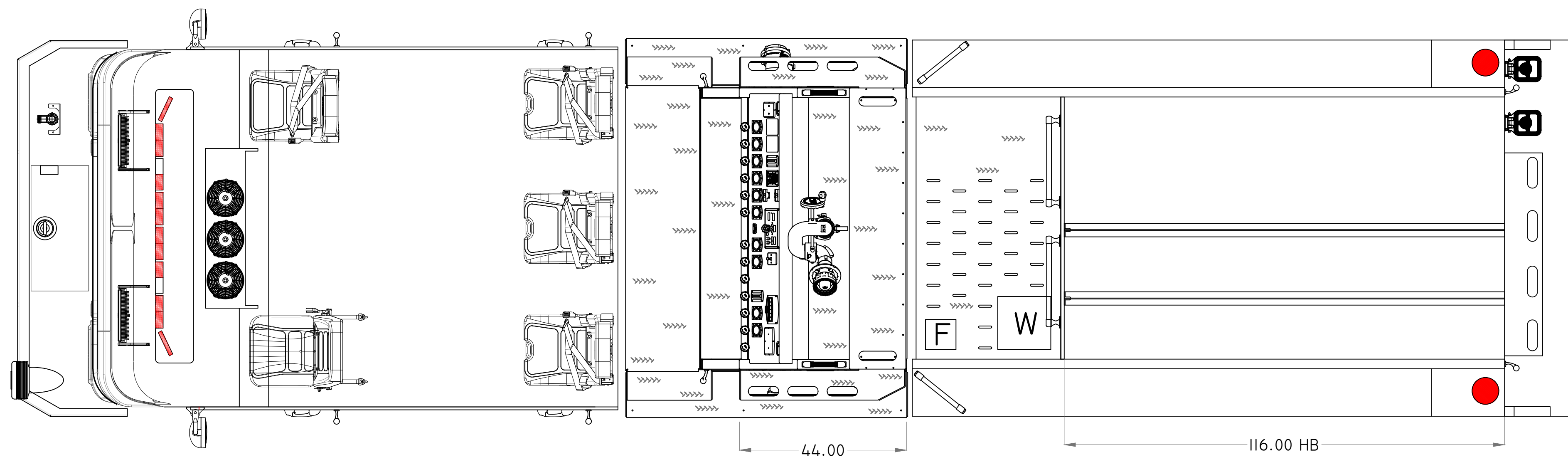

CHASSIS: SPARTAN METRO STAR EMFD 10" RR
 ENGINE: CUMMINS X12 500 HP
 TRANSMISSION: ALLISON 4000 EVS
 AXLES: F 21,500 LB / R 26,000 LB
 MODEL: 3120
 WATER/FOAM: 750 GALLONS / 20 GALLONS
 PUMP: WATEROUS CSU I500 GPM
 FOAM SYSTEM: FoAMPro I600
 GENERATOR: N/A

DOOR FRAMED OPENINGS	
COMPARTMENT	DOOR FRAMED OPENING
L1	32.25-W x 68.0-H
L2	68.0-W x 43.0-H
L3	44.25-W x 68.0-H
R1	32.25-W x 68.0-H
R2	68.0-W x 43.0-H
R3	44.25-W x 68.0-H
BI	36.0-W x 36.875-H

SPECIAL NOTES:

LADDER PACKAGE

- (1) DUO-SAFETY 24 FT.-2 SEC, 900A
- (1) DUO-SAFETY 14 FT. ROOF, 775A
- (1) DUO-SAFETY 10 FT. ATTIC, 585A

STORAGE FOR

- (1) 18" x 72" FERNO BACKBOARD
- (2) PIKE POLES WITH STANDARD HOOK
- (1) ARSON TRASH HOOK, UP TO 12FT LONG

CUSTOMER

THIS DRAWING IS A CLOSE APPROXIMATION OF YOUR FIRE APPARATUS. IN ALL CASES WHERE THE DRAWING AND THE WRITTEN SPECIFICATION DIFFER, THE SPECIFICATION SHALL PREVAIL. PLEASE WORK WITH YOUR DEALER TO ASSURE THAT THE WRITTEN SPECIFICATION REPRESENTS WHAT YOU WANT IN YOUR FINISHED PRODUCT. SPARTAN EMERGENCY RESPONSE BUILDS TO THE WRITTEN SPECIFICATION, NOT THE DRAWING TO ASSURE THAT YOUR NEEDS ARE MET.

PROPRIETARY AND CONFIDENTIAL

THE INFORMATION CONTAINED IN THIS DRAWING IS THE SOLE PROPERTY OF SPARTAN EMERGENCY RESPONSE. ANY REPRODUCTION IN PART OR AS A WHOLE WITHOUT THE WRITTEN PERMISSION OF SPARTAN EMERGENCY RESPONSE IS PROHIBITED. SPARTAN MOTORS USA, INC. D/B/A SPARTAN EMERGENCY RESPONSE.

REV	DATE	DESCRIPTION	NAME
0	02/7/23	UPDATE FROM 2120-10	WC

CUSTOMER: SCALE: NOT TO SCALE

TRUCK NUMBER: MODEL 3120-10
 DEALER:



Metro Fire Apparatus Specialists, Inc.
17350 State Hwy 249, Suite 250
Houston, Texas 77064-1142
713.692.0911 Office
www.mfas.com

SPARTAN S-180 MODEL 3120-10 BASE SPECIFICATIONS

INTENT OF SPECIFICATIONS

It shall be the intent of these specifications to provide a complete apparatus equipped as hereinafter and as specified. With a view to obtaining the best results and the most acceptable apparatus for service in the Department, these specifications cover only the general requirements as to the type of construction and tests to which the apparatus must conform, together with certain details as to finish, equipment and appliances with which the successful bidder shall conform. Minor details of construction and materials where not otherwise specified are left to the discretion of the contractor, who shall be solely responsible for the design and construction for all features. The manufacturer shall provide loose equipment only when specified by the customer. The (NFPA) 1901, Standard for Automotive Fire Apparatus, unless otherwise specified as requested by the customer in these specifications, shall prevail.

The apparatus must meet all NFPA, DOT, ICC, AE, SAE, UL, TRA, FMVSS and local state Motor Vehicle Requirements.

It is required that the apparatus be manufactured to current NFPA edition standards, all NFPA equipment (LOOSE EQUIPMENT) not specified in the specifications will not be provided by the contractor.

Bids shall only be considered from companies that have an established reputation in the field of fire apparatus construction that have been in business and construction for a minimum of twenty-five (25) years.

The bidder of the apparatus herein specified; shall be wholly owned (100%) and managed by a Company, Corporation, and/or Parent Company that is wholly based, and permanently resides in the United States of America.

The Company, Corporation, and/or Parent Company and all assets belonging to such; shall be wholly owned and managed (100%) by the entities specified above.

The bidder shall state the location of the manufacturing facility where the apparatus is to be built and the location of the parent company if a subsidiary of a manufacturer.

The bidder shall provide satisfactory evidence of their ability to construct the apparatus specified in the bidders manufacturing facilities.

The bidder's representation shall state the length of time representing the manufacturer of specified apparatus.

Due to the severe service requirements the department will impose on the apparatus as specified, each bidder shall provide a list of at least six (6) departments in which similar apparatus utilizing the brand of chassis proposed have been in service for over one year. This list shall include contact names and phone numbers.

Due to the importance of keeping this vital piece of firefighting apparatus in service with a minimum of downtime, the manufacturer shall maintain a network of service centers with factory-training personnel.

The bid shall be accompanied by a set of "Contractor's Specifications" consisting of a detailed description of the apparatus being furnished under this contract which conform. Computer runoff sheets are not acceptable as "Contractor's Specifications". Item compliance shall be indicated in the "Yes/No" column of each item by all Bidders. Note: Each bidder shall submit their bid in the same sequence as these specifications to allow the department to easily compare.

These specifications shall indicate size, type, model and make of all component parts and equipment.

METRO FIRE APPARATUS

QUALITY AND WORKMANSHIP

The design of the Apparatus shall embody the latest approved automotive engineering practices.

The workmanship must be of the highest quality in its respective field. Special consideration will be given to the following points: Accessibility of the various units, which require periodic maintenance, ease of operation (including both pumping and driving) and symmetrical proportions.

Construction shall be rugged and ample safety factors shall be provided to carry loads as specified and to meet both on and off road requirements and to speed conditions as set forth under "Performance tests and requirements".

Welding shall be employed in the assembly of the apparatus in a manner that will not prevent the ready removal of any component part for service or repair, with apparatus bodies of bolt together design not being acceptable.

All steel welding shall follow American Welding Society requirements for AWS D1.1:2012 Structural Welding Code for welding steel structural assemblies. All aluminum welding shall follow American Welding Society requirements for AWS D1.2/D1.2M:2003 Structural Welding Code for any type of structure made from aluminum structural alloys. All sheet metal welding shall follow American Welding Society AWS D9.1M/D9.1:2006 Structural Welding code for Arc/Braze requirements of non-structural materials. All pressure pipe welding shall follow American Society of Mechanical Engineers ASME IX/ ASME B31:2010 requirements to the qualification of procedures in welding and brazing, in accordance with the ASME Boiler and Pressure Vessel Code and the ASME B31 Code for Pressure Piping. Flux core arc welding to use alloy rods, type 7000, American Welding Society AWS standards A5.20-E70T1.

DELIVERY

The bidder shall provide the number of calendar days from the date the bid is awarded to the delivery of the completed unit.

A qualified delivery engineer representing the contractor shall deliver the apparatus and instruct the Fire Department personnel in the proper operation, care and maintenance of the equipment delivered.

To ensure proper break-in of all components while still under warranty, the apparatus shall be delivered under its own power. The unit will remain insured by the apparatus manufacturer until the department accepts the unit.

PERFORMANCE TESTS AND REQUIREMENTS

A road test shall be conducted with the apparatus fully loaded to its estimated in-service weight and shall be capable of the following performance while on dry paved roads that are in good condition and for a continuous run of ten (10) miles or more, during which time the apparatus shall show no loss of power or overheating. The transmission drive shaft or shafts and rear axles shall run quietly and be free from abnormal vibration or noise throughout the operating range of the apparatus. The successful bidder shall furnish a Weight Certificate showing weights on front axle, rear axles and total weight for the completed apparatus at time of delivery.

- A. The apparatus shall be capable of accelerating to 35 MPH (55 km/hr) from a standing start within 25 seconds on a level concrete highway without exceeding the maximum governed RPM of the engine.
- B. The apparatus, fully loaded, shall be capable of obtaining a minimum top speed of 50 MPH (80 km/hr) on a level dry concrete highway with the engine not exceeding its governed RPM (fully loaded).
- C. The service brakes shall be capable of stopping a fully loaded vehicle in 35ft (10.7 m) at 20 mph (32.2 km/hr) on a level concrete highway. The air brake system shall conform to Federal Motor Vehicle Safety Standards (FMVSS) 121.
- D. The apparatus, when fully loaded, shall have not less than 25 percent or more than 50 percent of the weight on the

METRO FIRE APPARATUS

front axle, and not less than 50 percent nor more than 75 percent on the rear axle.

- E. From a steady pace of 15 mph, the vehicle will accelerate to a true speed of 35 mph within 15 seconds. This will be accomplished without moving gear selector.
- F. The apparatus will be able to maintain a speed of at least 20 mph on any grade up to and including 6 percent.
- G. The contractor shall have the Underwriter's Laboratories, LLC conduct the tests of the apparatus as in accordance with standard practices required by the Underwriter Laboratories, LLC (Guide for the Certification of Fire Department Pumper latest edition). A copy of all tests shall accompany the Apparatus. (For apparatus sold within Canadian ULC S515 latest revision shall prevail).
- H. The contractor shall furnish copies of the Pump Manufacturer's Certification of hydrostatic test, the Engine Manufacturer current certified brake horsepower curve, and the Manufacturer's record of pumper construction details when delivered.
- I. All fluid levels and applicable pressures will be brought to proper levels and noted prior to final delivery.

INFORMATION REQUIRED

The manufacturer shall supply at time of delivery, a complete operation and maintenance manual covering the completed apparatus as delivered.

A Fire Apparatus Safety Guide published by Fire Apparatus Manufacturer's Association shall be provided with the apparatus upon delivery. This manual includes essential safety information for fire fighters, fire chiefs, apparatus mechanics, and fire department safety officers. The guide is applicable to municipal, wildland, and airport firefighting apparatus manufactured on either custom or commercial chassis.

A permanent plate shall be mounted in the driver's compartment to specify the quantity and type of the following fluids used in the vehicle: Engine oil, engine coolant, and chassis transmission fluid, pump transmission lubrication fluid, pump primer fluid (if used) and drive axle lubrication fluid.

The manufacture shall supply the final certification of GVWR and GAWR on a nameplate affixed to the vehicle.

A permanent plate in the driver's compartment shall be installed, specifying the seating capacity of the enclosed cab.

Signs that state "OCCUPANTS MUST BE SEATED AND BELTED WHEN APPARATUS IS IN MOTION" shall be provided and will be visible from each seated position. An accident prevention sign shall be located at the rear step area of the apparatus. It shall warn all personnel that standing on the step while apparatus is in motion shall be prohibited.

A nameplate indicating the chassis transmission shift selector position to be used when pumping shall be provided in the driving compartment and located so that it can be easily read from the driver's position.

LIABILITY

The bidder, if their bid is accepted, shall defend any and all suits and assume all liability for the use of any patented device or article forming part of the apparatus or any appliance provided under the contract.

GENERAL CONSTRUCTION

The apparatus shall be designed with due consideration to distribution of load between the front and rear axles, so that all specified equipment, including filled water tank, a full complement of personnel and fire hose will be carried without injury to the apparatus. Weight balance and distribution shall be in accordance with the recommendations of the (NFPA) 1901, Standard for Automotive Fire Apparatus, documentation.

METRO FIRE APPARATUS

The apparatus shall be designed so that all recommended daily maintenance checks can be performed easily by the operator without the need for hand tools. Apparatus components that interfere with repair or removal of other major components must be attached with fasteners (cap, screws, nuts, etc.) so that the components can be removed and installed with normal hand tools. These components must not be welded or otherwise permanently secured into place.

The GAWR and GVWR of the chassis shall be adequate to carry the fully equipped apparatus including all tanks filled, the specified hose load, unequipped personnel weight, ground ladders and a miscellaneous equipment allowance per NFPA criteria. It shall be the responsibility of the purchaser to provide the contractor with the weight of equipment to be carried if it is in excess of the allowance as set forth by NFPA.

The unequipped personnel weight shall be calculated at 250 lbs. per person times the maximum number of persons to ride on the apparatus.

The height of the fully loaded vehicle's center of gravity shall not exceed the chassis manufacturer's maximum limit.

The front to rear weight distribution of the fully loaded vehicle shall be within the limits set by the chassis manufacturer. The front axle loads shall not be less than the minimum axle loads specified by the chassis manufacturer, under full loads and all other loading conditions.

The difference in weight on the end of each axle, from side to side, when the vehicle is fully loaded and equipped shall not exceed 7 percent.

The apparatus shall be so designed that the various parts are readily accessible for lubrication, inspection, adjustment and repair.

Where special tools manufactured or designed by the contractor and are required to provide routine service on any component of the apparatus built or supplied by the contractor, such tools shall be provided with the apparatus.

EXCEPTIONS TO SPECIFICATIONS

The following specifications shall be strictly adhered to. Exceptions shall be allowed if they are equal to or superior to that as specified and providing, they are listed and entirely explained on a separate page entitled "Exceptions to Specifications". The exceptions list to refer to specification page number and paragraph.

Proposals taking total exception to specifications or total exception to certain parts of the specifications such as Electrical Systems, Chassis, Body or Pump, will not be accepted.

Prototype units will not be acceptable. Apparatus shall be inspected upon completion for compliance with specifications.

Deviations will not be tolerated and will be cause for rejection of Apparatus unless they were originally listed in bidder's proposal and accepted in writing by the department.

If the bidder takes an exception, on the exception page, the bidder must state an option price to bring their specifications into full compliance with the Department specifications.

Failure to provide this information shall be cause to reject the proposal as being non-responsive.-

Copied or run off sheets of these specifications shall be unacceptable, and the bid will be rejected no exceptions.

WARRANTY

Warranties applicable to the chassis and body (excluding vendor supplied components {engine, transmission, axles, etc.} which carry their own specific warranties) will be addressed by a single point warranty service provider approved by the manufacturer to perform service as necessary.

METRO FIRE APPARATUS

PURCHASER'S RIGHTS

The Purchaser reserves the right to accept or reject any or all bids as it deemed in their best interests.

BID DRAWING

For purposes of evaluation, the bidder shall provide a drawing illustrating, but not limited to, the overall dimensions, wheelbase, and overall length of the proposed apparatus. Other specified equipment shall be required to be included with the bidder's proposal package.

The drawings shall be large "D" size (minimum 24.00 inches x 36.00 inches). Smaller size drawings, "similar to" drawings or general sales drawings, shall not be acceptable.

Failure to provide a bid evaluation drawing in accordance with these specifications shall be cause for rejection of the bid proposal.

APPROVAL DRAWING

After the award of the bid, the contractor shall provide detailed colored engineering drawings including, but not limited to, the overall dimensions, wheelbase, and overall length of the proposed apparatus for use during the pre-construction conference.

The drawings shall include, but shall not be limited to, the right, left, top, front and rear views of the apparatus.

SINGLE SOURCE MANUFACTURER

Bids shall only be accepted from a single source apparatus manufacturer.

The definition of a single source manufacturer is a company that designs and manufactures their products utilizing an approach that includes complete product integration, including the apparatus chassis, cab, and body modules being constructed, assembled, and tested on company premises only.

Warranties qualified to the chassis and body design construction (excluding vendor component warranties such as engine, axles, transmission, and pumps, etc.) will be from a single source manufacturer and not separated between manufacturers (i.e., body and chassis). The bidder shall provide evidence of maintaining compliance to this requirement.

FINITE ELEMENT ANALYSIS AND TESTING

Finite Element Analysis (FEA) shall be provided by the manufacturer.

Prototype bodies have been subjected to rigorous testing over varied terrains simulating different environmental conditions.

The purpose of such complex engineering methods of analysis shall be to ensure the longevity of the design by analyzing stress levels throughout the body and incorporating the structural supports wherever necessary.

There shall have been a minimum of three (3) different load cases (per DOT, FHWA, and TTMA recommended practice) applied and analyzed to properly display the different areas and levels of stresses that will be present under the various operating conditions of the apparatus.

In addition to the FEA analysis, the core product design shall be strain gauged instrumental to ensure validation of FEA results and "Real World" drive/apparatus driving conditions.

Analysis shall also have been conducted on the mounting system for the apparatus body and pump house.

METRO FIRE APPARATUS

EXCEPTIONS TO THIS STATEMENT MAY BE CAUSE FOR IMMEDIATE REJECTION AND/OR BE CONSIDERED NON-COMPLIANT.

SUPPLIED INFORMATION & EXTRAS

The apparatus manufacturer shall supply two (2) hard copies of apparatus manuals with all manufactured apparatus.

The manuals shall include, but not be limited to: all component warranties, users' manuals and information for supplied products, apparatus engineering information including drawings and build prints, and whatever other pertinent information the manufacturer can supply to its customer regarding the said apparatus.

Included in the delivery of the unit, the manufacturer shall also include spare hardware and extra fasteners, paint for touch-up, information regarding washing and care procedures, as well as other recommendations for care and maintenance of the general apparatus.

The manufacturer shall also supply a manufacturer's record of apparatus construction details, including the following information:

- Owner name and address;
- Apparatus manufacturer, model, and serial number;
- Chassis make, model, and serial number;
- GAWR of front and rear axles;
- Front tire size and total rated capacity in kilograms;
- Rear tire size and total rated capacity in kilograms;
- Chassis weight distribution in kilograms with water (if applicable) and manufacturer mounted equipment (front and rear);
- Engine make, model, serial number, rated horsepower, related speed and no load governed speed;
- Type of fuel and fuel tank capacity;
- Electrical system voltage and alternator output in amps;
- Battery make and model, capacity in CCA
- Paint numbers;
- Weight documents from a certified scale showing actual loading on the front axle, rear axle(s), and overall vehicle (with the water tank full (if applicable) but without personnel, equipment, and hose);
- Written load analysis and results of the electrical system performance tests;
- Transmission make, model, and type;
- Pump to drive through the transmission (yes or no);
- Engine to pump gear ratio and transmission gear ratio used;
- Pump make model, rated capacity in gallons per minute, serial number, and number of stages;
- Pump manufacturer's certification of suction capability;
- Pump manufacturer's certification of hydrostatic test;
- Pump manufacturer's certification of inspection and test for the fire pump;
- Copy of the apparatus manufacturer's approval for stationary pumping applications;
- Pump transmission make, model and serial number;
- Priming device type;
- Type of pump pressure control system;
- The engine manufacturer's certified brake horsepower curve for the engine furnished, showing the maximum no load governed speed;
- Certification of the water tank capacity.

METRO FIRE APPARATUS

LIABILITY INSURANCE COVERAGE

In order to protect the department and its personnel, the bidder shall show proof that it has no less than \$10 million dollars in liability insurance in force. A certificate of coverage shall be included in the bid package. Failure to carry liability insurance of at least this amount or failure to include proof of coverage shall be cause to reject the bidder's proposal.

GENERAL WARRANTY

The manufacturer shall provide a two (2) year warranty from the date of delivery.

In the case of a commercial chassis being used, the warranty on the chassis, engine, transmission, tires, storage batteries, generators, electrical lamps and other devices subject to deterioration is limited to the warranty of the manufacturer thereof and adjustments for the same are to be made directly with the manufacturer by the customer.

STRUCTURAL BODY WARRANTY

A structural Aluminum body warranty shall be provided by the apparatus manufacturer for products of its manufacture to be free from defects in material and workmanship, under normal use and service, for a period of ten (10) years.

PAINT WARRANTY

A Prorated Paint Warranty shall be provided by the apparatus manufacturer for products of its manufacture to be free from defects in material and workmanship, under normal use and service, for a period of ten (10) years.

PUMP WARRANTY

Waterous Company shall provide a limited manufacturer's pump warranty to be free from defects, under normal use and service, for a period of seven (7) years from the date placed into service.

PLUMBING WARRANTY

A Stainless Steel Plumbing/Piping warranty shall be provided by the apparatus manufacturer for products of its manufacture to be free from defects in material and workmanship, under normal use and service, for a period of ten (10) years from the date of delivery.

TANK WARRANTY

A lifetime tank warranty shall be provided by the tank manufacturer, Pro Poly.

MULTI-PLEXED ELECTRICAL WARRANTY

A four (4) year limited (V-MUX) multiplex system warranty, of Weldon Technologies, Inc., shall be provided by the apparatus manufacturer, for parts and labor, while under normal use and service, against mechanical, electrical and physical defects from the date of installation.

The warranty shall exclude: sensors, shunt interface modules, serial or USB kits, transceivers, cameras, GPS, and electrical display screens, which shall be limited to a period of one (1) time a year repair for parts and labor from the date of installation. Please see the official warranty document in the appendix (attached) for specific details.

PUMP CERTIFICATION AND TESTING

The apparatus upon completion will be tested and certified by Underwriters Laboratories, LLC. The certification tests will follow the guidelines outlined in (NFPA) 1901, Standard for Automotive Fire Apparatus.

METRO FIRE APPARATUS

There shall be multiple tests performed by the contractor and Underwriter's Laboratories, LLC when the apparatus has been completed. The manufacturer shall provide the completed Test Certificate(s) to the purchaser at time of delivery. The inspection services of Underwriters Laboratories, LLC are available to all bidders on an equal basis; therefore, no third party certification of testing results shall be acceptable.

If the pumping system provided is rated at 3000gpm (12,000 L/min) or less, the pump shall be capable of delivering the following:

- (1) One hundred percent of rated capacity at 150 psi (1000 kPa) net pump pressure.
- (2) Seventy percent of rated capacity at 200 psi (1400 kPa) net pump pressure.
- (3) Fifty percent of rated capacity at 250 psi (1700 kPa) net pump pressure.

If the fire pump has a rated capacity of 750gpm (3000 L/min) or greater, the pump shall be tested after the pump and all its associated piping and equipment have been installed on the apparatus.

The tests shall include at least the pumping test, the pumping engine overload test, the pressure control system test, the priming device tests, and the vacuum test.

A test plate shall be provided at the pump operator's panel that gives the rated discharges and pressures together with the speed of the engine as determined by the certification test for each unit, the position of the parallel/series pump as used, and the governed speed of the engine as stated by the engine manufacturer on a certified brake horsepower curve. The plate shall be completely stamped with all information at the factory and attached to the vehicle prior to shipping.

Pumping Test:

The test site shall be adjacent to a supply of clear water at least 4 ft. (1.2 m) deep, with the water level not more than 10 ft. (3 m) below the center of the pump intake, and close enough to allow the suction strainer to be submerged at least 2 ft. (0.6 m) below the surface of the water when connected to the pump by 20 ft. (6 m) of suction hose.

Tests shall be performed when conditions are as follows:

- (1) Air temperature: 0°F to 110°F (-18°C to 43°C)
- (2) Water temperature: 35°F to 90°F (2°C to 32°C)
- (3) Barometric pressure: 29 in. Hg (98.2 kPa), minimum (corrected to sea level)

Engine-driven accessories shall not be functionally disconnected or otherwise rendered inoperative during the tests.

The following devices shall be permitted to be turned off or not operating during the pump test:

- (1) Foam pump
- (2) Winch
- (3) Windshield wipers
- (4) Four-way hazard flashers
- (5) Compressed air foam system (CAFS) compressor

All structural enclosures, such as floorboards, gratings, grilles, and heat shields, not provided with a means for opening them in service shall be kept in place during the tests.

METRO FIRE APPARATUS

All test gauges shall meet the requirements for Grade A gauges as defined in ASME B40.100, *Pressure Gauges and Gauge Attachments*, and shall be at least size 3½ per ASME B40.100. The pump intake gauge shall have a range of 30 in. Hg (100 kPa) vacuum to zero for a vacuum gauge, or 30 in. Hg (100 kPa) vacuum to a gauge pressure of 150 psi (1000 kPa) for a compound gauge. The discharge pressure gauge shall have a gauge pressure range of 0 psi to 400 psi (0 kPa to 2800 kPa). All pilot gauges shall have a gauge pressure range of at least 0 psi to 160 psi (0 kPa to 1100 kPa). All gauges shall be calibrated in the month preceding the tests using a dead-weight gauge tester or a master gauge meeting the requirements for Grade 3A or 4A gauges, as defined in ASME B40.100, *Pressure Gauges and Gauge Attachments*, that has been calibrated within the preceding year.

The engine speed-measuring equipment shall consist of a nonadjustable tachometer supplied from the engine or transmission electronics, a revolution counter on a checking shaft outlet and a stopwatch, or other engine speed-measuring means that is accurate to within ± 50 rpm of actual speed.

The pump shall be subjected to a 3 hour pumping test from draft consisting of 2 hours of continuous pumping at rated capacity at a minimum of 150 psi (1000 kPa) net pump pressure, followed by ½ hour of continuous pumping at 70 percent of rated capacity at a minimum of 200 psi (1400 kPa) net pump pressure and ½ hour of continuous pumping at 50 percent of rated capacity at a minimum of 250 psi (1700 kPa) net pump pressure and shall not be stopped until after the 2 hour test at rated capacity, unless it becomes necessary to clean the suction strainer.

Pumping Engine Overload Test:

The apparatus shall be subjected to an overload test consisting of pumping rated capacity at 165 psi (1100 kPa) net pump pressure for at least 10 minutes.

This test shall be performed immediately following the pumping test of rated capacity at 150 psi (1000 kPa).

The capacity, discharge pressure, intake pressure, and engine speed shall be recorded at least three times during the overload test.

Pressure Control System Test:

The pressure control system on the pump shall be tested as follows:

- (1) The pump shall be operated at draft, delivering rated capacity at a discharge gauge pressure of 150 psi (1000 kPa).
- (2) The pressure control system shall be set in accordance with the manufacturer's instructions to maintain the discharge gauge pressure at 150 psi (1000 kPa) ± 5 percent.
- (3) All discharge valves shall be closed not more rapidly than in 3 seconds and not more slowly than in 10 seconds.
- (4) The rise in discharge pressure shall not exceed 30 psi (200 kPa) and shall be recorded.
- (5) The original conditions of pumping rated capacity at a discharge gauge pressure of 150 psi (1000 kPa) shall be reestablished.
- (6) The discharge pressure gauge shall be reduced to 90 psi (620 kPa) by throttling the engine fuel supply, with no change to the discharge valve settings, hose, or nozzles.
- (7) The pressure control system shall be set according to the manufacturer's instructions to maintain the discharge gauge pressure at 90 psi (620 kPa) ± 5 percent.
- (8) All discharge valves shall be closed not more rapidly than in 3 seconds and not more slowly than in 10 seconds.
- (9) The rise in discharge pressure shall not exceed 30 psi (200 kPa) and shall be recorded.

METRO FIRE APPARATUS

(10) The pump shall be operated at draft, pumping 50 percent of rated capacity at a discharge gauge pressure of 250 psi (1700 kPa).

(11) The pressure control system shall be set in accordance with the manufacturer's instructions to maintain the discharge gauge pressure at 250 psi (1700 kPa) \pm 5 percent.

(12) All discharge valves shall be closed not more rapidly than in 3 seconds and not more slowly than in 10 seconds.

(13) The rise in discharge pressure shall not exceed 30 psi (200 kPa) and shall be recorded.

Priming System Tests:

With the apparatus set up for the pumping test, the primer shall be operated in accordance with the manufacturer's instructions until the pump has been primed and is discharging water. This test shall be permitted to be performed in connection with priming the pump for the pumping test.

The interval from the time the primer is started until the time the pump is discharging water shall be noted. The time required to prime the pump shall not exceed 30 seconds if the rated capacity is 1250 gpm (5000 L/min) or less. The time required to prime the pump shall not exceed 45 seconds if the rated capacity is 1500 gpm (6000 L/min) or more.

An additional 15 seconds shall be permitted in order to meet the requirements of 16.13.5.3 and 16.13.5.4 when the pump system includes an auxiliary 4 in. (100 mm) or larger intake pipe having a volume of 1 ft³ (0.03 m³) or more.

Vacuum Test:

The vacuum test shall consist of subjecting the interior of the pump, with all intake valves open, all intakes capped or plugged, and all discharge caps removed, to a vacuum of 22 in. Hg (75 kPa) by means of the pump priming system.

At altitudes above 2000 ft. (600 m), the vacuum attained shall be permitted to be less than 22 in. Hg (75 kPa) by 1 in. Hg (3.4 kPa) for each 1000 ft. (305 m) of altitude above 2000 ft. (610 m).

The vacuum shall not drop more than 10 in. Hg (34 kPa) in 5 minutes.

The primer shall not be used after the 5 minute test period has begun and the engine shall not be operated at any speed greater than the governed speed during this test.

Water Tank-to-Pump Flow Test:

A water tank-to-pump flow test shall be conducted as follows:

(1) The water tank shall be filled until it overflows.

(2) All intakes to the pump shall be closed.

(3) The tank fill line and bypass cooling line shall be closed.

(4) Hose lines and nozzles for discharging water at the rated tank-to-pump flow rate shall be connected to one or more discharge outlets.

(5) The tank-to-pump valve(s) and the discharge valves leading to the hose lines and nozzles shall be fully opened.

(6) The engine throttle shall be adjusted until the required flow rate $-0/+5$ percent is established.

(7) The discharge pressure shall be recorded.

METRO FIRE APPARATUS

- (8) The discharge valves shall be closed, and the water tank refilled.
- (9) The bypass line shall be permitted to be opened temporarily, if needed, to keep the water temperature in the pump within acceptable limits.
- (10) The discharge valves shall be reopened fully, and the time noted.
- (11) If necessary, the engine throttle shall be adjusted to maintain the discharge pressure recorded as noted in 16.13.7.1(7).
- (12) When the discharge pressure drops by 10 psi (70 kPa) or more, the time shall be noted and the elapsed time from the opening of the discharge valves shall be calculated and recorded.

Volume Discharge Calculation:

The volume discharged shall be calculated by multiplying the rate of discharge in gallons per minute (liters per minute) by the time in minutes elapsed from the opening of the discharge valves until the discharge pressure drops by at least 10 psi (70 kPa).

Other means shall be permitted to be used to determine the volume of water pumped from the tank such as a totalizing flowmeter, weighing the truck before and after, or refilling the tank using a totalizing flowmeter.

The rated tank-to-pump flow rate shall be maintained until 80 percent of the rated capacity of the tank has been discharge.

Engine Speed Advancement Interlock Test

The engine speed advancement interlock system shall be tested to verify that engine speed cannot be increased at the pump operator's panel unless there is throttle-ready indication.

If the apparatus is equipped with a stationary pump driven through split-shaft PTO, the test shall verify that the engine speed control at pump operator's panel cannot be advanced when either of the following conditions exists:

- (1) The chassis transmission is in neutral, the parking brake is off, and the pump shift in the driving compartment is in the road position.
- (2) The chassis transmission has been placed in the position for pumping as indicated on the label provided in the driving compartment, the parking brake is on, and the pump shift in the driving compartment is in the road position.

If the apparatus is equipped with a stationary pump driven through a transmission mounted PTO, front-of-engine crankshaft PTO, or engine flywheel PTO, the test shall verify that the engine speed control on the pump operator's panel cannot be advanced when either of the following conditions exists:

- (1) The chassis transmission is in neutral, the parking brake is off, and the pump shift status in the driving compartment is disengaged.
- (2) The chassis transmission is in any other gear other than neutral, the parking brake is on, and the pump shift in the driving compartment is in the "Pump Engaged" position.

If the apparatus is equipped with a pump driven by the chassis engine designed for both stationary pumping and pump-in-motion, the test shall verify that the engine speed control at pump operator's panel cannot be advanced when either of the following conditions exists:

METRO FIRE APPARATUS

- (1) The chassis transmission is in neutral, the parking brake is on, and the pump shift status in the driving compartment is disengaged.
- (2) The chassis transmission is in any other gear other than neutral, the parking brake is on, and the pump shift in the driving compartment is in the “Pump Engaged” or the “OK to Pump In-Motion” position.

If the apparatus is equipped with a stationary pump driven through transfer case PTO, the test shall verify that the engine speed control on the pump operator’s panel cannot be advanced when either of the following conditions exists:

- (1) The chassis transmission is in neutral, the transfer case is in neutral, the parking brake is off, and the pump shift in the driving compartment is in the road position.
- (2) The chassis transmission is in neutral, the transfer case is engaged, the parking brake is off, and the pump shift in the driving compartment is in the road position.
- (3) The chassis transmission has been placed in the position for pumping as indicated on the label provided in the driving compartment, the parking brake is on, and the pump shift in the driving compartment is in the road position.

LOW-VOLTAGE ELECTRICAL SYSTEM PERFORMANCE TESTING

The apparatus low-voltage electrical system will be tested and certified. Tests shall be performed when the air temperature is between 0°F and 110°F (–18°C and 43°C). The three tests defined in NFPA shall be performed in the order in which they appear. Before each test, the batteries shall be fully charged until the voltage stabilizes at the voltage regulator set point and the lowest charge current is maintained for 10 minutes. Failure of any of these tests shall require a repeat of the sequence.

Reserve Capacity Test:

The engine shall be started and kept running until the engine and engine compartment temperatures are stabilized at normal operating temperatures and the battery system is fully charged.

The engine shall be shut off and the minimum continuous electrical load shall be activated for 10 minutes.

All electrical loads shall be turned off prior to attempting to restart the engine. The battery system shall then be capable of restarting the engine. Failure to restart the engine shall be considered a test failure of the battery system.

Alternator Performance Test at Idle:

The minimum continuous electrical load shall be activated with the engine running at idle speed.

The engine temperature shall be stabilized at normal operating temperature.

The battery system shall be tested to detect the presence of battery discharge current. The detection of battery discharge current shall be considered a test failure.

Alternator Performance Test at Full Load:

The total continuous electrical load shall be activated with the engine running up to the engine manufacturer’s governed speed.

The test duration shall be a minimum of 2 hours.

Activation of the load management system shall be permitted during this test.

METRO FIRE APPARATUS

An alarm sounded by excessive battery discharge, as detected by the system required in NFPA 13.3.4, or a system voltage of less than 11.8 V dc for a 12 V nominal system or 23.6 V dc for a 24 V nominal system, for more than 120 seconds, shall be considered a test failure.

Low Voltage Alarm Test:

Following the above test, a Low Voltage Alarm Test will be performed in the manner prescribed.

With the engine shut off, the total continuous electrical load shall be activated and shall continue to be applied until the excessive battery discharge alarm activates.

The battery voltage shall be measured at the battery terminals.

The test shall be considered a failure if the alarm has not yet sounded 140 seconds after the voltage drops to 11.70V for a 12 V nominal system or 23.4 V for a 24 V nominal system.

The battery system shall then be able to restart the engine. Failure to restart the engine shall be considered a test failure.

Certification Documentation:

At the time of delivery, the manufacturer shall provide the following documentation:

(1) Documentation of the electrical system performance tests.

(2) A written electrical load analysis, including the following:

(a) The nameplate rating of the alternator.

(b) The alternator rating under the conditions specified above.

(c) Each of the component loads specified that make up the minimum continuous electrical load.

(d) Additional electrical loads that, when added to the minimum continuous electrical load, determine the total continuous electrical load.

(e) Each individual intermittent electrical load.

WARNING AND INFORMATION LABELS

All warning and informational labels (non-vendor specific) shall be provided in compliance with (NFPA) 1901, Standard for Automotive Fire Apparatus, and installed in the appropriate locations to alert the operator of potential hazards and operating instructions.

NO PRE-CONSTRUCTION CONFERENCE

There shall be no Pre-construction conference, prior to manufacturing, with individuals from the Fire Department.

NO FINAL INSPECTION

There shall be no Final- Inspection unless otherwise specified.

NFPA 1901

The apparatus and product orientation of the vehicle will be provided per NFPA 1901-2016 revision.

METRO FIRE APPARATUS

MAXIMUM OVERALL LENGTH REQUIREMENT

The Apparatus specified shall be constructed with no restrictions to the Maximum Overall Length.

MAXIMUM OVERALL HEIGHT REQUIREMENT

The Apparatus specified shall be constructed as detailed and shall NOT exceed a Maximum Overall Height of 10 feet 2 inches.

MAXIMUM WHEEL BASE REQUIREMENT

The Apparatus specified shall be constructed as detailed and shall NOT exceed a Maximum Wheel Base of 209.50 inches.

MODEL

The chassis shall be a Metro Star model. The cab and chassis shall include design considerations for multiple emergency vehicle applications, rapid transit and maneuverability. The chassis shall be manufactured for heavy duty service with the strength and capacity to support a fully laden apparatus, one hundred (100) percent of the time.

MODEL YEAR

The chassis shall have a vehicle identification number that reflects a 2024 model year.

COUNTRY OF SERVICE

The chassis shall be put in service in the country of United States of America (USA).

The chassis will meet applicable U.S.A. federal motor vehicle safety standards per CFR Title 49 Chapter V Part 571 as clarified in the incomplete vehicle book per CFR Title 49 Chapter V Part 568 Section 4 which accompanies each chassis. The chassis manufacturer is not responsible for compliance to state, regional, or local regulations. Dealers should identify those regulations and order any necessary optional equipment from the chassis manufacturer or their OEM needed to be in compliance with those regulations.

CAB AND CHASSIS LABELING LANGUAGE

The cab and chassis shall include the applicable caution, warning, and safety notice labels with text to be written in English. All applicable caution, warning, and safety notice labels shall be Innovative Controls brand. Where applicable to the location within the specific layout and label package of the cab and chassis, the labels shall include decorative chrome bezels. Designs shall include bezels that fit individual labels or packaged configurations of labels in certain common locations.

APPARATUS TYPE

The apparatus shall be a pumper vehicle designed for emergency service use which shall be equipped with a permanently mounted fire pump which has a minimum rated capacity of 750 gallons per minute (3000 L/min). The apparatus shall include a water tank and hose body whose primary purpose is to combat structural and associated fires.

VEHICLE TYPE

The chassis shall be manufactured for use as a straight truck type vehicle and designed for the installation of a permanently mounted apparatus behind the cab. The apparatus of the vehicle shall be supplied and installed by the apparatus manufacturer.

METRO FIRE APPARATUS

VEHICLE ANGLE OF APPROACH PACKAGE

The angle of approach of the apparatus shall be a minimum of 8.00 degrees.

NFPA1901 Angle of Approach definition:

“To determine the angle of approach, place a thin steel strip against the front of the tires where they touch the ground or stretch a tight string from one front tire to the other at the front where they touch the ground. Determine the lowest point (component or equipment) on the vehicle forward of the front tire that would make the smallest angle of approach. Hang a plumb bob from the lowest point and mark the point on the ground where the point of the plumb bob touches. Measure the vertical distance from the ground to the point where the plumb bob was hung (distance V). Measure the horizontal distance from the plumb bob point to the steel strip or string running from front tire to front tire (distance H). Divide the vertical distance by the horizontal distance. The ratio of V/H is the tangent of the angle of approach. If the ratio is known, the angle of approach can be determined from a table of trigonometric functions of angles or from a math calculator. The standard requires a minimum angle of approach of 8.00 degrees: since the tangent of 8.00 degrees is 0.1405, if V divided by H is 0.1405 or larger, the angle of approach is 8.00 degrees or greater.”

AXLE CONFIGURATION

The chassis shall feature a 4 x 2 axle configuration consisting of a single rear drive axle with a single front steer axle.

GROSS AXLE WEIGHT RATINGS FRONT

The front gross axle weight rating (GAWR) of the chassis shall be 21,500 pounds.

This front gross axle weight rating shall be adequate to carry the weight of the completed apparatus including all equipment and personnel.

GROSS AXLE WEIGHT RATINGS REAR

The rear gross axle weight rating (GAWR) of the chassis shall be 26,000 pounds.

This rear gross axle weight rating shall be adequate to carry the weight of the completed apparatus including all equipment and personnel.

PUMP PROVISION

The chassis shall include provisions to mount a drive line pump in the middle of the chassis, behind the cab, more commonly known as the midship location. Chassis driveline pump provisions shall include an interlock feature for automatic setting of the park brake when the vehicle is shifted into pump mode while the transmission is in neutral and the transmission output speed translates to less than 1 mph. When the conditions are met the driver side parking brake valve shall activate. Once shifted to road mode the condition for electric automatic brake engagement is no longer present and the driver's parking brake control valve shall function normally.

WATER & FOAM TANK CAPACITY

The chassis shall include a carrying capacity of 750 gallons (2839 liters) to 1250 gallons (4732 liters). The water and/or foam tank(s) shall be supplied and installed by the apparatus manufacturer.

CAB STYLE

The cab shall be a custom, fully enclosed, EMFD model with a 10.00 inch raised roof over the driver, officer, and crew area, designed and built specifically for use as an emergency response vehicle by a company specializing in cab and chassis design for all emergency response applications. The cab shall be designed for heavy-duty service utilizing

METRO FIRE APPARATUS

superior strength and capacity for the application of protecting the occupants of the vehicle. This style of cab shall offer up to eight (8) seating positions.

The cab shall incorporate a fully enclosed design with side wall roof supports, allowing for a spacious cab area with no partition between the front and rear sections of the cab. To provide a superior finish by reducing welds that fatigue cab metal; the roof, the rear wall and side wall panels shall be assembled using a combination of welds and proven industrial adhesives designed specifically for aluminum fabrication for construction.

The cab shall be constructed using multiple aluminum extrusions in conjunction with aluminum plate, which shall provide proven strength and the truest, flattest body surfaces ensuring less expensive paint repairs if needed. All aluminum welding shall be completed to the American Welding Society and ANSI D1.2-96 requirements for structural welding of aluminum.

All interior and exterior seams shall be sealed for optimum noise reduction and to provide the most favorable efficiency for heating and cooling retention.

The cab shall be constructed of 5052-H32 corrosion resistant aluminum plate. The cab shall incorporate tongue and groove fitted 6061-T6 0.13 & 0.19 inch thick aluminum extrusions for extreme duty situations. A single formed, one (1) piece extrusion shall be used for the "A" pillar, adding strength and rigidity to the cab as well as additional roll-over protection. The cab side walls and lower roof skin shall be 0.13 inch thick; the rear wall and raised roof skins shall be 0.09 inch thick; the front cab structure shall be 0.19 inch thick.

The exterior width of the cab shall be 94.00 inches wide with a minimum interior width of 88.00 inches. The overall cab length shall be 137.10 inches with 60.00 inches from the centerline of the front of the axle to the back of the cab.

The cab interior shall be designed to afford the maximum usable interior space and attention to ergonomics with hip and legroom while seated which exceeds industry standards. The crew cab floor shall be flat across the entire walking area for ease of movement inside the cab.

The cab shall offer an interior height of 57.50 inches from the front floor to the headliner and a rear floor to headliner height of 65.00 inches in the raised roof area, at a minimum. The cab shall offer an interior measurement at the floor level from the rear of the engine tunnel to the rear wall of the cab of 57.88 inches. All interior measurements shall include the area within the interior trimmed surfaces and not to any unfinished surface.

The cab shall include a driver and officer area with two (2) cab doors large enough for personnel in full firefighting gear. The front doors shall offer a clear opening of 40.25 inches wide X 53.50 inches high, from the cab floor to the top of the door opening. The cab shall also include a crew area with up to two (2) cab doors, also large enough for personnel in full firefighting gear. The rear doors shall offer a clear opening of 32.25 inches wide X 61.00 inches high, from the cab floor to the top of the door opening.

The cab shall incorporate a progressive two (2) step configuration from the ground to the cab floor at each door opening. The progressive steps are vertically staggered and extend the full width of each step well allowing personnel in full firefighting gear to enter and exit the cab easily and safely.

The first step for the driver and officer area shall measure approximately 11.50 inches deep X 31.13 inches wide. The intermediate step shall measure approximately 8.50 inches deep X 32.50 inches wide. The height from the first step to the intermediate step and the intermediate step to the cab floor shall not exceed 11.00 inches.

The first step for the crew area shall measure approximately 11.50 inches deep X 20.44 inches wide. The intermediate step shall measure approximately 10.25 inches deep X 22.75 inches wide. The height from the first step to the intermediate step and the intermediate step to the cab floor shall not exceed 12.80 inches.

METRO FIRE APPARATUS

CAB FRONT FASCIA

The front cab fascia shall be constructed of 5052-H32 Marine Grade, 0.13 of an inch thick aluminum plate which shall be an integral part of the cab.

The cab fascia will encompass the entire front of the aluminum cab structure from the bottom of the windshield to the bottom of the cab and shall be the "Classic" design.

The front cab fascia shall include two (2) molded plastic modules on each side accommodating a total of up to four (4) Hi/Low beam headlights and two (2) turn signal lights or up to four (4) warning lights. A chrome plated molded plastic bezel shall be provided on each side around each set of four lamps.

FRONT GRILLE

The front fascia shall include a box style, 304 stainless steel front grille 44.45 inches wide X 33.50 inches high X 1.50 inches deep. The grille shall include a minimum free air intake of 732.00 square inches. The upper portion of the grille shall be hinged to provide service access behind the grille.

CAB UNDERCOAT

There shall be a rubberized undercoating applied to the underside of the cab that provides abrasion protection, sound deadening and corrosion protection.

CAB SIDE DRIP RAIL

There shall be a drip rail along the top radius of each cab side. The drip rails shall help prevent water from the cab roof running down the cab side.

CAB PAINT EXTERIOR

The cab exterior shall be painted a single color per customers specified paint color.

CAB PAINT PROCESS/MANUFACTURER

The cab shall be painted with Sikkens paint prior to the installation of glass accessories and all other cab trim to ensure complete paint coverage and the maximum in corrosion protection of all metal surfaces.

All metal surfaces on the cab shall be mechanically etched by sanding disc to remove any surface oxidation or surface debris which may hinder the paint adhesion. Once all imperfections on the exterior surfaces are removed and sanded smooth, body fillers shall be applied to the cab on all surfaces that require a critically aesthetic finish and sanded smooth.

The entire cab shall then be coated with a high quality base primer that is designed to fill any minor surface defects, provide an adhesive bond between the primer and the paint and improve the color and gloss retention of the color. The finish to this procedure shall be sanding the cab to a smooth finish followed by sealing the seams with an automotive seam sealer. The minimum thickness of the primer coat after sanding shall be 2.50 mils with a maximum thickness of 5.00 mils.

The cab shall then be painted the specific color(s) designated by the customer with an acrylic urethane type system designed to retain color and resist acid rain and most atmospheric chemicals found on an emergency scene. The paint shall have a minimum thickness of 1.00 mils with a maximum of 4 mils, followed by a clear top coat with a minimum of 2.5 mils and a maximum of 3.5 mils. The entire cab shall then be baked to speed the curing process of the coatings.

METRO FIRE APPARATUS

CAB PAINT PRIMARY/LOWER COLOR

The lower paint color shall be Sikkens FLNA 32528 Red.

CAB PAINT WARRANTY

Purchaser shall receive a Paint and Finish (Exterior Clear coated) Ten (10) Years limited warranty in accordance with, and subject to, warranty certificate RFW0710. The warranty certificate is incorporated by reference into this proposal, and included with this proposal or available upon request.

CAB PAINT INTERIOR

The visible interior cab structure surfaces shall feature a medium gray spray on bedliner coating which shall mold to each surface of the cab interior. The bedliner shall be environmentally friendly and chemically resistant.

CAB ENTRY DOORS

The cab shall include four (4) entry doors, two (2) front doors and two (2) crew doors designed for ease of entering and egress when outfitted with an SCBA. The doors shall be constructed of extruded aluminum with a nominal thickness of 0.13 inch. The exterior skins shall be constructed of 0.13 inch aluminum plate.

The doors shall include a double rolled style automotive rubber seal around the perimeter of each door frame and door edge which ensures a weather tight fit.

All door hinges shall be hidden within flush mounted cab doors for a pleasing smooth appearance and perfect fit along each side of the cab. Each door hinge shall be piano style with a 0.38 inch pin and shall be constructed of stainless steel.

CAB ENTRY DOOR TYPE

All cab entry doors shall be barrier clear design resulting in exposed lower cab steps. The doors shall provide approximately 32.00 inches of clearance from the ground to the bottom of the door so cab doors may be opened un-hindered by most obstacles encountered, such as guard rails along interstate highways.

Entry doors shall include Pollak mechanical plunger style switches for electrical component activation.

CAB INSULATION

The cab ceiling and walls shall include a nonwoven polyester fiber insulation. The insulation shall act as a barrier absorbing noise as well as assisting in sustaining the desired climate within the cab interior.

CAB STRUCTURAL WARRANTY

Purchaser shall receive a Cab Structure (Aluminum) Ten (10) Years or 100,000 Miles limited warranty in accordance with, and subject to, warranty certificate RFW0602. The warranty certificate is incorporated by reference into this proposal, and included with this proposal or available upon request.

CAB TEST INFORMATION

The cab shall have successfully completed the preload side impact, static roof load application and frontal impact without encroachment to the occupant survival space when tested in accordance with Section 4 of SAE J2420 COE Frontal Strength Evaluation Dynamic Loading Heavy Trucks, Section 5 of SAE J2422 Cab Roof Strength Evaluation Quasi – Static Loading Heavy Trucks and ECE R29 Uniform Provisions Concerning the Approval of Vehicles with regard to the Protection of the Occupants of the Cab of a Commercial Vehicles Annex 3 Paragraph 5.

METRO FIRE APPARATUS

The above tests have been witnessed by and attested to by an independent third party. The test results were recorded using cameras, high speed imagers, accelerometers and strain gauges. Documentation of the testing shall be provided upon request.

ELECTRICAL SYSTEM

The chassis shall include a single starting electrical system which shall include a 12 volt direct current multiplexing system, suppressed per SAE J551. The wiring shall be appropriate gauge cross link with 311 degree Fahrenheit insulation. All SAE wires in the chassis shall be color coded and shall include the circuit number and function where possible. The wiring shall be protected by 275 degree Fahrenheit minimum high temperature flame retardant loom. All nodes and sealed Deutsch connectors shall be waterproof.

OEM WIRING

The wiring system shall include custom wiring provisions to meet the needs of OEM stock unit bodies.

MULTIPLEX DISPLAY

The multiplex electrical system shall include an UltraView 780 display with an interactive touchscreen display and fourteen (14) tactile push buttons. The display shall be located on the left side of the dash in the switch panel. The display shall feature a full color 7.00 inch LCD display screen which shall include a message bar displaying the time of day and important messages requiring acknowledgement by the user. The display screen shall be video ready for back-up cameras, thermal cameras, and 360 camera systems.

The display shall offer varying fonts and background colors. The display shall be fully programmable to the needs of the customer and shall offer virtually infinite flexibility for screen configuration options.

MULTIPLEX DISPLAY SPECIAL LAYOUT

The Vista display and control screen shall be configured specifically for the vista dimmer control screen to have two dimmer settings. The dimmer settings shall be labeled "DAY" (Normal) and "NIGHT". This shall omit the additional default settings "MAX" and "DIM".

LOAD MANAGEMENT SYSTEM

The apparatus load management shall be performed by the included multiplex system. The multiplex system shall also feature the priority of sequences and shall shed electrical loads based on the priority list specifically programmed.

DATA RECORDING SYSTEM

The chassis shall have a Weldon Vehicle Data Recorder (VDR) system installed. The system shall be designed to meet NFPA 1901 and shall be integrated with the Weldon Multiplex electrical system. The following information shall be recorded:

- Vehicle Speed
- Acceleration
- Deceleration
- Engine Speed
- Engine Throttle Position
- ABS Event
- Seat Occupied Status
- Seat Belt Status
- Master Optical Warning Device Switch Position
- Time

METRO FIRE APPARATUS

- Date

Each portion of the data shall be recorded at the specified intervals and stored for the specified length of time to meet NFPA 1901 guidelines and shall be retrievable by connecting a laptop computer to the VDR system. The laptop connection shall be a panel mounted female type B USB connection point, remotely mounted in the left side foot well.

ACCESSORY POWER

The electrical distribution panel shall include two (2) power studs. The studs shall be size #10 and each of the power studs shall be circuit protected with a fuse of the specified amperage. One (1) power stud shall be capable of carrying up to a 40 amp battery direct load. One (1) power stud shall be capable of carrying up to a 15 amp ignition switched load. The two (2) power studs shall share one (1) #10 ground stud.

An OEM body connections bracket shall be installed on the chassis near the left hand battery box. The bracket shall include one (1) set each of 200 amp master power switched and 300 amp battery direct fused power and ground studs.

AUXILIARY ACCESSORY POWER

An auxiliary six (6) position Blue Sea Systems 5025 blade type fuse panel shall be installed behind the switch panel. The fuse panel shall be protected by a 40 amp fuse. The panel shall be capable of carrying up to a maximum 40 amp battery direct load.

ADDITIONAL ACCESSORY POWER

An additional six (6) position Blue Sea Systems 5025 blade type fuse panel shall be installed on the side wall of the engine tunnel behind the officer's seat. The fuse panel shall be protected by a 40 amp fuse. The panel shall be capable of carrying up to a maximum 40 amp battery direct load.

EXTRA ACCESSORY POWER

An extra six (6) position Blue Sea Systems 5025 blade type fuse panel shall be provided and installed on the lower rear wall of the cab above the seat frame. The fuse panel shall be offset left of the cab centerline between the forward facing center seat and the forward facing outer seat. The fuse panel shall be protected by a 40 amp fuse and be wired battery direct.

EXTERIOR ELECTRICAL TERMINAL COATING

All terminals exposed to the elements will be sprayed with a high visibility protective rubberized coating to prevent corrosion.

ELECTRICAL SYSTEM WARRANTY

Purchaser shall receive an Electrical System Two (2) Years or 36,000 Miles limited warranty in accordance with, and subject to, warranty certificate RFW0202. The warranty certificate is incorporated by reference into this proposal, and included with this proposal or available upon request.

ENGINE

The chassis engine shall be a Cummins X12 engine. The X12 engine shall be an in-line six (6) cylinder, four cycle diesel powered engine. The engine shall offer a rating of 500 horse power at 1900 RPM and shall be governed at 2000 RPM. The torque rating shall feature 1700 foot pounds of torque at 1000 RPM with 720 cubic inches (11.8 liter) of displacement.

METRO FIRE APPARATUS

The X12 engine shall feature a VGT™ Turbocharger, a high pressure common rail fuel system, fully integrated electronic controls with an electronic governor, and shall be EPA certified to meet the 2021 emissions standards using cooled exhaust gas recirculation and selective catalytic reduction technology.

The engine shall include an engine mounted combination full flow/by-pass oil filter with replaceable spin on cartridge for use with the engine lubrication system. The engine shall include Citgo brand Citgard 500, or equivalent SAE 15W40 CK-4 low ash engine oil which shall be utilized for proper engine lubrication.

A wiring harness shall be supplied ending at the back of the cab. The harness shall include a connector which shall allow an optional harness for the pump panel. The included circuits shall be provided for a tachometer, oil pressure, engine temperature, hand throttle, high idle and a PSG system. A circuit for J1939 data link shall also be provided at the back of the cab.

CAB ENGINE TUNNEL

The cab interior shall include an integrated engine tunnel constructed of 5052-H32 Marine Grade, 0.19 of an inch thick aluminum. The tunnel shall be a maximum of 41.50 inches wide X 25.50 inches high.

DIESEL PARTICULATE FILTER CONTROLS

There shall be two (2) controls for the diesel particulate filter. One (1) control shall be for regeneration and one (1) control shall be for regeneration inhibit.

ENGINE PROGRAMMING HIGH IDLE SPEED

The engine high idle control shall maintain the engine idle at approximately 1250 RPM when engaged.

ENGINE HIGH IDLE CONTROL

The vehicle shall be equipped with a virtual Vista button and an automatic high-idle speed control. It shall be pre-set so when activated, it will operate the engine at the appropriate RPM to increase alternator output. This device shall operate only when the engine is running and the transmission is in neutral with the parking brake set. The device shall disengage when the operator depresses the brake pedal, or the transmission is placed in gear, and shall be available to manually or automatically re-engage when the brake is released, or when the transmission is placed in neutral. There shall be an indicator on the Vista display and control screen for the high idle speed control.

ENGINE PROGRAMMING ROAD SPEED GOVERNOR

The engine shall include programming which will govern the top speed of the vehicle.

AUXILIARY ENGINE BRAKE

A compression brake, for the six (6) cylinder engine shall be provided. A cutout relay shall be installed to disable the compression brake when in pump mode or when an ABS event occurs. The engine compression brake shall activate upon 0% accelerator when in operation mode and actuate the vehicle's brake lights.

The engine shall utilize a variable geometry turbo (VGT) as an integrated auxiliary engine brake to offer a variable rate of exhaust flow, which when activated in conjunction with the compression brake shall enhance the engine's compression braking capabilities.

AUXILIARY ENGINE BRAKE CONTROL

An engine compression brake control device shall be included. The electronic control device shall monitor various conditions and shall activate the engine brake only if all of the following conditions are simultaneously detected:

METRO FIRE APPARATUS

- A valid gear ratio is detected.
- The driver has requested or enabled engine compression brake operation.
- The throttle is at a minimum engine speed position.
- The electronic controller is not presently attempting to execute an electronically controlled final drive gear shift.

The compression brake shall be controlled via an off/low/medium/high virtual button on the Vista display and control screen. The multiplex system shall remember and default to the last engine brake control setting when the vehicle is shut off and re-started.

ELECTRONIC ENGINE OIL LEVEL INDICATOR

The engine oil shall be monitored electronically and shall send a signal to activate a warning in the instrument panel when levels fall below normal. The warning shall activate in a low oil situation upon turning on the master battery and ignition switches without the engine running.

FLUID FILLS

The front of the chassis shall accommodate fluid fill for the engine oil through the grille. This area shall also accommodate a check for the engine oil. The transmission, power steering, and coolant fluid fills and checks shall be under the cab. The windshield washer fill shall be accessible through the front left side mid step.

ENGINE DRAIN PLUG

The engine shall include an original equipment manufacturer installed oil drain plug.

ENGINE WARRANTY

The Cummins engine shall be warranted for a period of five (5) years or 100,000 miles, whichever occurs first.

REMOTE THROTTLE HARNESS

An apparatus interface wiring harness for the engine and transmission pump interlocks shall be supplied with the chassis. The harness shall include a connector for connection to a chassis pump panel harness supplied by the body builder and shall terminate in the left frame rail behind the cab for connection by the body builder. The harness shall include circuits deemed for a pump panel and shall contain circuits for a hand throttle, and a multiplexed gauge. Separate circuits shall also be included for a pump control switch, "Pump Engaged" and "OK to Pump" indicator lights, open compartment ground, start signal, park brake ground, ignition signal, master power, clean power, customer ignition, air horn solenoid switch, high idle switch and high idle indicator light. The harness shall contain interlocks that will prevent shifting to road or pump mode unless the transmission output speed translates to less than 1 mph and the transmission is in neutral. The shift to pump mode shall also require the park brake be set.

ENGINE PROGRAMMING REMOTE THROTTLE

The engine ECM (Electronic Control Module) discreet wire remote throttle circuit shall be turned off for use with a J1939 based pump controller or when the discreet wire remote throttle controls are not required.

ENGINE PROGRAMMING IDLE SPEED

The engine low idle speed will be programmed at 700 rpm.

ENGINE AIR INTAKE

The engine air intake system shall include an ember separator. This ember separator shall be designed to protect the downstream air filter from embers using a combination of unique flat and crimped metal screens packaged in a heavy

METRO FIRE APPARATUS

duty galvanized steel frame. This multilayered screen shall trap embers and allow them to burn out before passing through the pack.

The engine air intake system shall also include an air cleaner mounted above the radiator. This air cleaner shall utilize a replaceable dry type filter element designed to prevent dust and debris from being ingested into the engine. A service cover shall be provided on the housing, reducing the chance of contaminating the air intake system during air filter service.

The air intake system shall include a restriction indicator light in the warning light cluster on the instrument panel, which shall activate when the air cleaner element requires replacement.

ENGINE FAN DRIVE

The engine cooling system fan shall incorporate a thermostatically controlled, Horton fully variable type fan drive with SmartClutch J-1939 CAN controller.

The variable speed fan clutch only engages at the amount needed for proper cooling to facilitate improved vehicle performance, cab heating in cold climates, and fuel economy. The fan clutch design shall be fail-safe so that if the clutch drive fails the fan shall engage to prevent engine overheating due to the fan clutch failure. The fan speed shall include a J-1939 CAN clutch controller to receive signal from the engine control module to activate at variable rates of speed. Variable speeds shall be set through thermostatic and engine speed signals to run as efficiently and quietly as required to maintain temperature.

ENGINE COOLING SYSTEM

There shall be a heavy-duty aluminum cooling system designed to meet the demands of the emergency response industry. The cooling system shall have the capacity to keep the engine properly cooled under all conditions of road and pumping operations. The cooling system shall be designed and tested to meet or exceed the requirements specified by the engine and transmission manufacturer and all EPA requirements. The complete cooling system shall be mounted to isolate the entire system from vibration or stress. The individual cores of the cooling system shall be mounted in a manner to allow expansion and contraction at various rates without inducing stress into the adjoining cores.

The cooling system shall be comprised of a charge air cooler to radiator serial flow package that provides the maximum cooling capacity for the specified engine as well as serviceability. The main components shall include a surge tank, a charge air cooler bolted to the front of the radiator, recirculation shields, a shroud, a fan, and required tubing.

The radiator shall be a down-flow design constructed with aluminum cores, plastic end tanks, and a steel frame. The radiator shall be equipped with a drain cock to drain the coolant for serviceability.

The cooling system shall include a one piece injected molded polymer fan with a three (3) piece fiberglass fan shroud.

The cooling system shall be equipped with a surge tank that is capable of removing entrained air from the system. The surge tank shall be equipped with a low coolant probe and rearward oriented sight glass to observe coolant in the system. A cold fill and observation line shall be included within the frame mounted translucent recovery bottle to monitor the level of the coolant. The surge tank shall have a dual seal cap that meets the engine manufacturer's pressure requirements and allows for expansion and recovery of coolant into a separate integral expansion chamber.

All radiator tubes shall be formed from aluminized steel tubing. Recirculation shields shall be installed where required to prevent heated air from reentering the cooling package and affecting performance.

The charge air cooler shall be a cross-flow design constructed completely of aluminum with cast tanks. All charge air cooler tubes shall be formed from aluminized steel tubing and installed with silicone hump hoses and stainless steel "constant torque" style clamps meeting the engine manufacturer's requirements.

METRO FIRE APPARATUS

The radiator and charge air cooler shall be removable through the bottom of the chassis.

ENGINE COOLING SYSTEM PROTECTION

The engine cooling system shall include a recirculation shield designed to act as a light duty skid plate below the radiator to provide additional protection for the engine cooling system from light impacts, stones, and road debris. The skid plate shall be painted to match the frame components.

ENGINE COOLANT

The cooling package shall include Extended Life Coolant (ELC). The use of ELC provides longer intervals between coolant changes over standard coolants providing improved performance. The coolant shall contain a 50/50 mix of ethylene glycol and de-ionized water to keep the coolant from freezing to a temperature of -34 degrees Fahrenheit.

Proposals offering supplemental coolant additives (SCA) shall not be considered, as this is part of the extended life coolant makeup.

ELECTRONIC COOLANT LEVEL INDICATOR

The instrument panel shall feature a low engine coolant indicator light which shall be located in the center of the instrument panel. An audible tone alarm shall also be provided to warn of a low coolant incident.

ENGINE PUMP HEAT EXCHANGER

A single bundle type coolant to water heat exchanger shall be installed between the engine and the radiator. The heat exchanger shall be designed to prohibit water from the pump from coming in contact with the engine coolant. This shall allow the use of water from the discharge side of the pump to assist in cooling the engine.

COOLANT HOSES

The cooling systems hose shall be formed silicone hose and formed aluminized steel tubing and include stainless steel constant torque band clamps.

ENGINE COOLANT OVERFLOW BOTTLE

A remote engine coolant overflow expansion bottle shall be provided in the case of over filling the coolant system. The overflow bottle shall capture the expansion fluid or overflow rather than allow the fluid to drain on the ground.

ENGINE EXHAUST SYSTEM

The exhaust system shall include an end-in end-out horizontally mounted single module after treatment device, and downpipe from the charge air cooled turbo. The single module shall include four temperature sensors, diesel particulate filter (DPF), urea dosing module (UL2), and a selective catalytic reduction (SCR) catalyst to meet current EPA standards. The selective catalytic reduction catalyst utilizes a diesel exhaust fluid solution consisting of urea and purified water to convert NOx into nitrogen, water, and trace amounts of carbon dioxide. The solution shall be mixed and injected into the system through the DPF and SCR.

The system shall utilize 0.07 inch thick stainless steel exhaust tubing between the engine turbo and the DPF. Zero leak clamps seal all system joints between the turbo and DPF.

The single module after treatment through the end of the tailpipe shall be connected with zero leak clamps. The discharge shall terminate horizontally on the right side of the vehicle ahead of the rear tires.

The exhaust system after treatment module shall be mounted below the frame in the outboard position.

METRO FIRE APPARATUS

DIESEL EXHAUST FLUID TANK

The exhaust system shall include a molded cross linked polyethylene tank for Diesel Exhaust Fluid (DEF). The tank shall have a capacity of six (6) usable gallons and shall be mounted on the left hand side of the chassis frame behind the batteries below the frame.

The DEF tank shall be designed with capacity for expansion in case of fluid freezing. Engine coolant, which shall be thermostatically controlled, shall be run through lines in the tank to help prevent the DEF from freezing and to provide a means of thawing the fluid if it should become frozen.

The tank fill tube shall be routed under the rear of the cab with the fill neck and splash guard accessible in the top rear step.

ENGINE EXHAUST ACCESSORIES

An exhaust temperature mitigation device shall be shipped loose for installation by the body manufacturer on the vehicle. The temperature mitigation device shall lower the temperature of the exhaust by combining ambient air with the exhaust gasses at the exhaust outlet.

The tail pipe shall have a 7.00 inch offset shifting the exhaust pipe inboard of the exhaust canister to provide additional clearance from the body and frame mounted brackets.

ENGINE EXHAUST WRAP

The exhaust tubing between the engine turbo and the diesel particulate filter (DPF) shall be wrapped with a thermal cover in order to retain the necessary heat for DPF regeneration. The exhaust wrap shall also help protect surrounding components from radiant heat which can be transferred from the exhaust.

The exhaust flex joint shall not include the thermal exhaust wrap.

EMISSIONS SYSTEMS WARRANTY

Purchaser shall receive a Regulated Emissions Systems Five (5) Years or 100,000 Miles limited warranty in accordance with, and subject to, warranty certificate RFW0140. The warranty certificate is incorporated by reference into this proposal, and included with this proposal or available upon request.

TRANSMISSION

The drive train shall include an Allison model EVS 4000 torque converting, automatic transmission which shall include electronic controls. The transmission shall feature two (2) 10-bolt PTO pads located on the converter housing.

The transmission shall include two (2) internal oil filters which shall offer Allison formulated Castrol TranSynd™ synthetic transmission fluid which shall be utilized in the lubrication of the EVS transmission. An electronic oil level sensor shall be included with the readout located in the shift selector.

The transmission gear ratios shall be:

1st	3.51:1
2nd	1.91:1
3rd	1.43:1
4th	1.00:1
5th	0.74:1
6th	0.64:1 (if applicable)
Rev	4.80:1

METRO FIRE APPARATUS

TRANSMISSION MODE PROGRAMMING

The transmission, upon start-up, will select the fifth speed operation without the need to press the mode button.

TRANSMISSION FEATURE PROGRAMMING

The Allison Gen V/VI-E transmission EVS group package number 127 shall contain the 198 vocational package in consideration of the duty of this apparatus as a pumper. This package shall incorporate an automatic neutral with selector override. This feature commands the transmission to neutral when the park brake is applied, regardless of drive range requested on the shift selector. This requires re-selecting drive range to shift out of neutral for the override.

This package shall be coupled with the use of a split shaft PTO and incorporate pumping circuits. These circuits shall be used allowing the vehicle to operate in the fourth range lockup while operating the pump mode due to the 1 to 1 ratio through the transmission, therefore the output speed of the engine is the input speed to the pump. The pump output can be easily calculated by using this input speed and the drive ratio of the pump itself to rate the gallons of water the pump can provide.

A transmission interface connector shall be provided in the cab. This package shall contain the following input/output circuits to the transmission control module. The Gen V/VI-E transmission shall include prognostic diagnostic capabilities. These capabilities shall include the monitoring of the fluid life, filter change indication, and transmission clutch maintenance.

<u>Function ID</u>	<u>Description</u>	<u>Wire assignment</u>
Inputs		
C	PTO Request	142
J	Fire Truck Pump Mode (4th Lockup)	122 / 123
Outputs		
C	Range Indicator	145 (4th)
G	PTO Enable Output	130
	Signal Return	103

TRANSMISSION SHIFT SELECTOR

An Allison pressure sensitive range selector touch pad shall be provided and located to the right of the driver within clear view and easy reach. The shift selector shall have a graphical Vacuum Florescent Display (VFD) capable of displaying two lines of text. The shift selector shall provide mode indication and a prognostic indicator (wrench symbol) on the digital display. The prognostics monitor various operating parameters and shall alert you when a specific maintenance function is required.

ELECTRONIC TRANSMISSION OIL LEVEL INDICATOR

The transmission fluid shall be monitored electronically and shall send a signal to activate a warning in the instrument panel when levels fall below normal.

TRANSMISSION PRE-SELECT WITH AUXILIARY BRAKE

When the auxiliary brake is engaged, the transmission shall automatically shift to second gear to decrease the rate of speed assisting the secondary braking system and slowing the vehicle.

TRANSMISSION COOLING SYSTEM

The transmission shall include a water to oil cooler system located in the cooling loop between the radiator and the engine. The transmission cooling system shall meet all transmission manufacturer requirements. The transmission cooling system shall feature continuous flow of engine bypass water to maintain uninterrupted transmission cooling.

METRO FIRE APPARATUS

TRANSMISSION DRAIN PLUG

The transmission shall include an original equipment manufacturer installed magnetic transmission fluid drain plug.

TRANSMISSION WARRANTY

The Allison EVS series transmission shall be warranted for a period of five (5) years with unlimited mileage. Parts and labor shall be included in the warranty.

PTO LOCATION

The transmission shall have two (2) power take off (PTO) mounting locations, one (1) in the 8:00 o'clock position and one (1) in the 1:00 o'clock position.

DRIVELINE

All drivelines shall be heavy duty metal tube and equipped with MSI 1810 series universal joints. The shafts shall be dynamically balanced prior to installation to alleviate future vibration. In areas of the driveline where a slip shaft is required, the splined slip joint shall be coated with Glide Coat®. The drivelines shall include Meritor brand u-joints with thrust washers.

MIDSHIP PUMP / GEARBOX

A temporary jackshaft driveline shall be installed by the chassis manufacturer to accommodate the mid-ship split shaft pump as specified by the apparatus manufacturer. Holes shall be provided as specified by the OEM for mounting a customer installed pump module.

See PDF for specific hole pattern.

MIDSHIP PUMP / GEARBOX MODEL

The midship pump/gearbox provisions shall be for a Waterous CSUC20 or C22 pump.

MIDSHIP PUMP GEARBOX DROP

The Waterous pump gearbox shall have a "C" (medium length) drop length.

MIDSHIP PUMP RATIO

The ratio for the midship pump shall be 2.27:1.

MIDSHIP PUMP LOCATION C/L SUCTION TO C/L REAR AXLE

The midship pump shall be located so the dimension from the centerline of the suction to the centerline of the rear axle is 95.50 inches.

PUMP SHIFT CONTROLS

One (1) air pump shift control panel shall be located on the left hand side of the engine tunnel, integrated with the shifter pod. The following shall be provided on the panel: a three (3) position control lever; an engraved PUMP ENGAGED identification light; and an engraved OK TO PUMP identification light. The pump shift control panel shall be black with a yellow border outline and shall include pump instructions. An instruction plate describing the transmission shift selector position used for pumping shall be provided and located so it can be read from the driver's position per NFPA 16.10.1.3.

METRO FIRE APPARATUS

The road mode shall be selected when the control lever is in the forward position and pump mode shall be selected when the control lever is in the rearward position.

The control lever center position shall exhaust air from both pump and road sides of the pump gear box shift cylinder.

PUMP SHIFT CONTROL PLUMBING

Air connections shall be provided from the air supply tank to the pump shift control valve and from the pump shift control valve to the frame mounted bracket. The frame mounted bracket shall include labeling identifying the pump and road connection points with threaded 0.25 inch NPT fittings on the solenoid for attaching the customer installed pump. The air supply shall be pressure protected from service brake system.

FUEL FILTER/WATER SEPARATOR

The fuel system shall have a Racor GreenMAX 6600R fuel filter/water separator as a primary filter. The fuel filter shall have a drain valve and a see-through cover to allow visual inspection of fuel and filter condition. The Racor 6600R shall meet engine requirements for particulate size, collection capacity, removal efficiency, and water removal efficiency. The filter shall be capable of handling a maximum flow rate of 150 gallons per hour.

A secondary fuel filter shall be included as approved by the engine manufacturer.

An instrument panel lamp and audible alarm which indicates when water is present in the fuel-water separator shall also be included.

FUEL LINES

The fuel system supply and return lines installed from the fuel tank to the engine shall be black textile braided lines which are reinforced with braided high tensile steel wire. The fuel lines shall be connected with reusable steel fittings.

FUEL SHUTOFF VALVE

There shall be two (2) fuel shutoff valves which shall be installed, one (1) in the fuel draw line at the primary fuel filter and one (1) in the fuel outlet line at the primary fuel filter to allow the fuel filters to be changed without loss of fuel to the fuel pump.

A third fuel shutoff valve shall be installed in the fuel draw line, near the fuel tank to allow maintenance to be performed with minimal loss of fuel.

ELECTRIC FUEL PRIMER

Integral to the engine assembly is an electric lift pump that serves the purpose of pre-filter fuel priming.

FUEL COOLER

A fuel cooler shall be provided to lower fuel temperature allowing the vehicle to operate at higher ambient temperatures. The fuel cooler shall include an electrical fan and temperature-controlled relay switch.

FUEL TANK

The fuel tank shall have a capacity of sixty-eight (68) gallons and shall measure 35.00 inches in width X 17.00 inches in height X 29.00 inches in length.

The baffled tank shall have a vent port to facilitate venting to the top of the fill neck for rapid filling without "blow-back" and a roll over ball check vent for temperature related fuel expansion and draw.

METRO FIRE APPARATUS

The tank is designed with dual draw tubes and sender flanges. The tank shall have 2.00 inch NPT fill ports for right or left hand fill. A 0.50 inch NPT drain plug shall be centered in the bottom of the tank.

The fuel tank shall be mounted below the frame, behind the rear axle. Two (2) three-piece strap hanger assemblies with "U" straps bolted midway on the fuel tank front and rear shall be utilized to allow the tank to be easily lowered and removed for service purposes. Rubber isolating pads shall be provided between the tank and the upper tank mounting brackets. Strap mounting studs through the rail, hidden behind the body shall not be acceptable.

FUEL TANK MATERIAL AND FINISH

The fuel tank shall be constructed of 12 gauge aluminized steel. The exterior of the tank shall be powder coated black and then painted to match the frame components.

All powder coatings, primers and paint shall be compatible with all metals, pretreatments and primers used. The cross hatch adhesion test per ASTM D3359 Method B, results to be 5B minimum. The pencil hardness test per ASTM D3363 shall have a final post-cured pencil hardness of H-2H. The direct impact resistance test per ASTM D2794, results to be 5B minimum.

Any proposals offering painted fuel tanks with variations from the above process shall not be accepted. The film thickness of vendor supplied parts shall also be sufficient to meet the performance standards as stated above.

FUEL TANK STRAP MATERIAL

The fuel tank straps shall be constructed of ASTM A-36 steel. The fuel tank straps shall be powder coated black and then painted to match the frame components if possible.

FUEL TANK FILL PORT

The fuel tank fill ports shall be provided with two (2) left fill ports located one (1) in the forward position and one (1) in the middle position and the right fill port located in the middle position of the fuel tank.

A 1.50 inch diameter hole shall be provided in the left and right frame rails for vent hose routing provisions. The holes shall be located adjacent to the fuel tank and 5.13 inches up from the bottom of each rail.

FUEL TANK SERVICEABILITY PROVISIONS

The chassis fuel lines shall have additional length provided so the tank can be easily lowered and removed for service purposes. The additional 8.00 feet of length shall be located above the fuel tank and shall be coiled and secured. The fuel line fittings shall be pointed towards the right side (curbside) of the chassis.

FUEL TANK DRAIN PLUG

A 0.5 inch NPT magnetic drain plug shall be centered in the bottom of the fuel tank.

FRONT AXLE

The front axle shall include a Reyco Granning ResponseMaster®, fire apparatus specific independent front suspension (IFS) offering superior ride and improved handling.

The suspension shall utilize fully independent double wishbone arms with carrier and kingpin for optimized scrub radius. Air springs are tuned for ride and help reduce suspension weight. The IFS reduces turn radius with improved wheel cut over beam axles. The hydraulic damper shall feature rebound control to ensure the maximum load stability and superior driver comfort. The IFS system shall improve handling and offer better braking because of improved

METRO FIRE APPARATUS

ground to tire ratio. This design shall allow for independent adjustment of the vehicle's alignment settings. The IFS shall include an auxiliary transverse leaf spring.

Proposals offering independent front axles comprised of torsion bar style suspensions shall not be considered.

FRONT AXLE WARRANTY

The front axle shall be warranted by Tuthill for three (3) years or 150,000 miles, which ever comes first. Details of the Tuthill warranty are provided on the PDF document attached to this option.

FRONT WHEEL BEARING LUBRICATION

The front axle wheel bearings shall be lubricated with oil. The oil level can be visually checked via clear inspection windows in the front axle hubs.

FRONT SHOCK ABSORBERS

Two (2) Koni shock absorbers shall be provided and installed as part of the front suspension system. Each shock shall deliver improved road handling and durability.

FRONT SUSPENSION

The chassis shall include an independent front suspension (IFS) system. The known advantages of IFS systems can be improved handling and better braking due to the increase in tire surface to ground contact area. The suspension travel of the IFS shall be approximately 6.50 inches, providing 3.00 inches bounce and 3.50 inches rebound of the suspension. The IFS front axle shall be rated between 21,000 and 24,000 pounds.

STEERING COLUMN/ WHEEL

The cab shall include a Douglas Autotech steering column which shall include a seven (7) position tilt, a 2.25 inch telescopic adjustment, and an 18.00 inch, four (4) spoke steering wheel located at the driver's position. The steering wheel shall be covered with black polyurethane foam padding.

The steering column shall contain a horn button, self-canceling turn signal switch, four-way hazard switch and headlamp dimmer switch.

ELECTRONIC POWER STEERING FLUID LEVEL INDICATOR

The power steering fluid shall be monitored electronically and shall send a signal to activate an audible alarm and visual warning in the instrument panel when fluid level falls below normal.

POWER STEERING PUMP

The hydraulic power steering pump shall be a TRW PS and shall be gear driven from the engine. The pump shall be a balanced, positive displacement, sliding vane type. The power steering system shall include an oil to air passive cooler.

FRONT AXLE CRAMP ANGLE

The chassis shall have a front axle cramp angle of 48-degrees to the left and right.

POWER STEERING GEAR

The power steering gear shall be a TRW model TAS 85/RCS 85.

METRO FIRE APPARATUS

CHASSIS ALIGNMENT

The chassis frame rails shall be measured to insure the length is correct and cross checked to make sure they run parallel and are square to each other. The front and rear axles shall be laser aligned. The front tires and wheels shall be aligned and toe-in set on the front tires by the chassis manufacturer.

REAR AXLE

The rear axle shall be a Meritor model RS-25-160 single drive axle. The axle shall include precision forged, single reduction differential gearing, and shall have a fire service rated capacity of 27,000 pounds.

The axle shall be built of superior construction and quality components to provide the rugged dependability needed to stand up to the fire industry's demands. The axle shall include rectangular shaped, hot-formed housing with a standard wall thickness of 0.63 of an inch for extra strength and rigidity and a rigid differential case for high axle strength and reduced maintenance.

The axle shall have heavy-duty Hypoid gearing for longer life, greater strength and quieter operation. Industry-standard wheel ends for compatibility with both disc and drum brakes, and unitized oil seal technology to keep lubricant in and help prevent contaminant damage will be used.

REAR AXLE DIFFERENTIAL LUBRICATION

The rear axle differential shall be lubricated with oil.

REAR AXLE WARRANTY

The rear axle shall be warranted by Meritor for five (5) years with unlimited miles under the general service application. Details of the Meritor warranty are provided on the PDF document attached to this option.

REAR WHEEL BEARING LUBRICATION

The rear axle wheel bearings shall be lubricated with oil.

VEHICLE TOP SPEED

The top speed of the vehicle shall be approximately 68 MPH +/-2 MPH at governed engine RPM.

REAR SUSPENSION

The single rear axle shall feature a Reyco 79KB vari-rate, self-leveling captive slipper type parabolic five (5) leaf spring pack suspension with 57.50 inch X 3.00 inch springs. The suspension shall also utilize two (2) torque arms with eccentric cam adjustment.

The rear suspension capacity shall be rated to 27,000 pounds.

REAR SHOCK ABSORBERS

Two (2) Bilstein inert, nitrogen gas filled shock absorbers shall be provided and installed as part of the rear suspension system. The shocks shall be a monotubular design and fabricated using a special extrusion method, utilizing a single blank of steel without a welded seam, achieving an extremely tight peak-to-valley tolerance and maintains consistent wall thickness. The monotubular design shall provide superior strength while maximizing heat dissipation and shock life.

METRO FIRE APPARATUS

The ride afforded through the use of a gas shock is more consistent and shall not deteriorate with heat, the same way a conventional oil filled hydraulic shock would.

The Bilstein front shocks shall include a digressive working piston assembly allowing independent tuning of the compression and rebound damping forces to provide optimum ride and comfort without compromise. The working piston design shall feature fewer parts than most conventional twin tube and "road sensing" shock designs and shall contribute to the durability and long life of the Bilstein shock absorbers.

Proposals offering the use of conventional twin tube or "road sensing" designed shocks shall not be considered.

TIRE INTERMITTENT SERVICE RATING

The chassis shall be rated using Intermittent Service ratings provided to the emergency vehicle market by the tire manufacturers as the basis for determining the maximum vehicle load and speed.

FRONT TIRE

The front tires shall be Michelin 385/65R22.5 "L" tubeless radial X Multi HL Z regional tread.

The front tire stamped load capacity shall be 22,000 pounds per axle with a nominal speed rating of 68 miles per hour when properly inflated to 130 pounds per square inch.

The Michelin Intermittent Service Rating maximum load capacity shall be 23,540 pounds per axle with a maximum speed of 68 miles per hour when properly inflated to 130 pounds per square inch.

The Michelin Intermittent Service Rating maximum speed capacity shall be 22,000 pounds per axle with a speed rating of 75 miles per hour when properly inflated to 130 pounds per square inch.

The Michelin Intermittent Service Rating limits the operation of the emergency vehicle to no more than fifty (50) miles of continuous operation under maximum recommended payload, or without stopping for at least twenty (20) minutes. The emergency vehicle must reduce its speed to no more than 50 MPH after the first fifty (50) miles of travel.

REAR TIRE

The rear tires shall be Michelin 12R-22.5 16PR "H" tubeless radial XZE regional tread.

The rear tire stamped load capacity shall be 27,120 pounds per axle with a speed rating of 75 miles per hour when properly inflated to 120 pounds per square inch.

The Michelin Tire Intermittent Service Rating load capacity shall be 28,880 pounds per axle with a speed rating of 75 miles per hour when properly inflated to 120 pounds per square inch. The Michelin Intermittent Service Rating limits the operation of the emergency vehicle to one (1) hour of loaded travel with a one (1) hour cool down prior to another loaded run.

REAR AXLE RATIO

The rear axle ratio shall be 4.89:1.

TIRE PRESSURE INDICATOR

There shall be electronic chrome LED valve caps shipped loose for installation by the OEM which shall illuminate with a red LED when tire pressure drops 8psi provided. The valve caps are self-calibrating and set to the pressure of the tire upon installation.

METRO FIRE APPARATUS

FRONT WHEEL

The front wheels shall be Alcoa hub piloted, 22.50 inch X 12.25 inch aluminum wheels. The outer face of the wheels shall feature Alcoa's Dura-Bright® finish as an integral part of the wheel surface. Alcoa Dura-Bright® wheels keep their shine without polishing. Brake dust, grime and road debris are easily removed by simply cleaning the wheels with soap and water. The hub piloted mounting system shall provide easy installation and shall include two-piece flange nuts.

REAR WHEEL

The rear wheels shall be Alcoa hub piloted, 22.50 inch X 8.25 inch aluminum wheels with a polished outer surface and Alcoa Dura-Bright® wheel treatment as an integral part of the wheel surface. The inner rear wheels shall be Alcoa hub piloted, 22.50 inch X 8.25 inch aluminum wheels with a polished inner and outer surface and Alcoa Dura-Bright® wheel treatment as an integral part of the wheel surface. The hub piloted mounting system shall provide easy installation and shall include two-piece flange nuts.

BALANCE WHEELS AND TIRES

All of the wheels and tires, including any spare wheels and tire assemblies, shall include Counteract brand balancing beads.

WHEEL TRIM

The front wheels shall include stainless steel lug nut covers and stainless steel baby moons shipped loose with the chassis for installation by the apparatus builder. The baby moons shall have cutouts for oil seal viewing when applicable.

The rear wheels shall include stainless steel lug nut covers and band mounted spring clip stainless steel high hats shipped loose with the chassis for installation by the apparatus builder.

The lug nut covers, baby moons, and high hats shall be RealWheels® brand constructed of 304L grade, non-corrosive stainless steel with a mirror finish. Each wheel trim component shall meet D.O.T. certification.

BRAKE SYSTEM

A rapid build-up air brake system shall be provided. The air brakes shall include, at a minimum, a two (2) air tank, three (3) reservoir system with a total of 4152 cubic inch of air capacity. A floor mounted treadle valve shall be mounted inside the cab for graduated control of applying and releasing the brakes. An inversion valve shall be installed to provide a service brake application in the unlikely event of primary air supply loss. All air reservoirs provided on the chassis shall be labeled for identification.

The rear axle spring brakes shall automatically apply in any situation when the air pressure falls below 25 PSI and shall include a mechanical means for releasing the spring brakes when necessary. An audible alarm shall designate when the system air pressure is below 60 PSI.

A four (4) sensor, four (4) modulator Anti-lock Braking System (ABS) shall be installed on the front and rear axles in order to prevent the brakes from locking or skidding while braking during hard stops or on icy or wet surfaces. This in turn shall allow the driver to maintain steering control under heavy braking and in most instances, shorten the braking distance. The electronic monitoring system shall incorporate diagonal circuitry which shall monitor wheel speed during braking through a sensor and tone ring on each wheel. A dash mounted ABS lamp shall be provided to notify the driver of a system malfunction. The ABS system shall automatically disengage the auxiliary braking system device when required. The speedometer screen shall be capable of reporting all active defaults using PID/SID and FMI standards.

METRO FIRE APPARATUS

Additional safety shall be accommodated through Automatic Traction Control (ATC) which shall be installed on the single rear axle. The ATC system shall apply the ABS when the drive wheels lose traction. The system shall scale the electronic engine throttle back to prevent wheel spin while accelerating on ice or wet surfaces.

A virtual style switch shall be provided and properly labeled "mud/snow". When the switch is pressed once, the system shall allow a momentary wheel slip to obtain traction under extreme mud and snow conditions. During this condition the ATC light shall blink continuously notifying the driver of activation. Pressing the switch again shall deactivate the mud/snow feature.

The Electronic Stability Control (ESC) unit is a functional extension of the electronic braking system. It is able to detect any skidding of the vehicle about its vertical axis as well as any rollover tendency. The control unit comprises an angular-speed sensor that measures the vehicle's motion about the vertical axis, caused, for instance, by cornering or by skidding on a slippery road surface. An acceleration sensor measures the vehicle's lateral acceleration. The Controller Area Network (CAN) bus provides information on the steering angle. On the basis of lateral acceleration and steering angle, an integrated microcontroller calculates a theoretical angular speed for the stable vehicle condition.

FRONT BRAKES

The front brakes shall be Knorr/Bremse SN7 disc brakes with 17.00 inch vented rotors.

REAR BRAKES

The rear brakes shall be Meritor EX225 Disc Plus disc brakes with 17.00 inch vented rotors.

PARK BRAKE

Upon application of the push-pull valve in the cab, the rear brakes will engage via mechanical spring force. This is accomplished by dual chamber rear brakes, satisfying the FMVSS parking brake requirements.

PARK BRAKE CONTROL

A Meritor-Wabco manual hand control push-pull style valve shall operate the parking brake system. The control shall be yellow in color.

The parking brake actuation valve shall be mounted in the switch panel. A horizontal orientation guard shall be installed over the parking brake control to prevent accidental application or release.

AIR DRYER

The brake system shall include a Wabco System Saver 1200 air dryer with an integral 100 watt heater with a Metri-Pack sealed connector. The air dryer incorporates an internal turbo cutoff valve that closes the path between the air compressor and air dryer purge valve during the compressor "unload" cycle. The turbo cutoff valve allows purging of moisture and contaminants without the loss of turbo boost pressure. The air dryer shall be located on the right hand frame rail forward of the front wheel behind the right hand cab step.

FRONT BRAKE CHAMBERS

The front brakes shall be provided with type 24 brake chambers as supplied with the independent front suspension axle.

METRO FIRE APPARATUS

REAR BRAKE CHAMBERS

The rear axle shall include TSE 24/30 H.O.T. (High Output Technology) brake chambers shall convert the energy of compressed air into mechanical force and motion. This shall actuate the brake camshaft, which in turn shall operate the foundational brake mechanism forcing the brake pads against the brake rotor.

AIR COMPRESSOR

The air compressor provided for the engine shall be a naturally aspirated Wabco® SS440 single cylinder pass-through drive type compressor which shall be capable of producing 26.0 CFM at 1200 engine RPMs. The compressor shall include an aluminum cylinder head which shall improve cooling, reduce weight and decrease carbon formation.

AIR GOVERNOR

An air governor shall be provided to control the cut-in and cut-out pressures of the engine mounted air compressor. The governor shall be calibrated to meet FMVSS requirements. The air governor shall be located on the air dryer bracket.

AUXILIARY AIR RESERVOIR

One (1) auxiliary air reservoir with a 2084 cubic inch capacity shall be installed on the chassis to act as an additional reserve supply to the air system for air horn, air tool, or other non-service brake use. The reservoir shall be isolated with a 90 PSI pressure protection valve on the reservoir supply side to prevent depletion of the air to the air brake system.

MOISTURE EJECTORS

Automatic moisture ejectors with a manual drain provision shall be installed on all reservoirs of the air supply system. The manual drain provision shall include an actuation pull cable coiled and tied at each drain valve. The supplied cables when extended shall be sufficient in length to allow each drain to be activated from the side of the apparatus.

AIR SUPPLY LINES

The air system on the chassis shall be plumbed with color coded reinforced nylon tubing air lines. The primary (rear) brake line shall be green, the secondary (front) brake line red, the parking brake line orange and the auxiliary (outlet) will be blue.

Brass compression type fittings shall be used on the nylon tubing. All drop hoses shall include fiber reinforced neoprene covered hoses.

AIR INLET CONNECTION

An air connection for the shoreline air inlet shall be supplied.

AIR INLET LOCATION

The air inlet shall be installed in the left hand side lower front step in the forward position.

AIR INLET/ OUTLET FITTING TYPE

The air connector supplied shall be a 0.25 inch size Tru-Flate Interchange style manual connection which is compatible with Milton 'T' style, Myers 0.25 inch Automotive style and Parker 0.25 inch 10 Series connectors.

METRO FIRE APPARATUS

AIR TANK SPACERS

There shall be spacers included with the air tank mounting. The spacers shall move the air tanks 3.00 inches inward towards the center of the chassis. This shall provide clearance between the air tanks and the frame for body U-bolt clearance.

REAR AIR TANK MOUNTING

If a combination of wheel base, air tank quantity, or other requirements necessitate the location of one or more air tanks to be mounted rear of the fuel tank, these tank(s) will be mounted parallel to frame.

WHEELBASE

The chassis wheelbase shall be 209.50 inches.

REAR OVERHANG

The chassis rear overhang shall be 47.00 inches.

FRAME

The frame shall consist of double rails running parallel to each other with cross members forming a ladder style frame. The frame rails shall be formed in the shape of a "C" channel, with the outer rail measuring 10.25 inches high X 3.50 inches deep upper and lower flanges X 0.38 inches thick with an inner channel of 9.44 inches high X 3.13 inches deep and 0.38 inches thick. Each rail shall be constructed of 110,000 psi minimum yield high strength low alloy steel. Each double rail section shall be rated by a Resistance Bending Moment (RBM) minimum of 3,213,100 inch pounds and have a minimum section modulus of 29.21 cubic inches. The frame shall measure 35.00 inches in width.

Proposals calculating the frame strength using the "box method" shall not be considered.

Proposals including heat treated rails shall not be considered. Heat treating frame rails produces rails that are not uniform in their mechanical properties throughout the length of the rail. Rails made of high strength, low alloy steel are already at the required yield strength prior to forming the rail.

A minimum of seven (7) fully gusseted 0.25 inch thick cross members shall be installed. The inclusion of the body mounting, or bumper mounting shall not be considered as a cross member. The cross members shall be attached using zinc coated grade 8 fasteners. The bolt heads shall be flanged type, held in place by distorted thread flanged lock nuts. Each cross member shall be mounted to the frame rails utilizing a minimum of 0.25 inch thick gusset reinforcement plates at all corners balancing the area of force throughout the entire frame.

Any proposals not including additional reinforcement for each cross member shall not be considered.

All relief areas shall be cut in with a minimum 2.00 inch radius at intersection points with the edges ground to a smooth finish to prevent a stress concentration point.

MISCELLANEOUS FRAME OPTIONS

The frame shall include hole patterns which shall be specific to Spartan ERV Legend style body mounting.

See PDF for OEM specified pattern.

METRO FIRE APPARATUS

REAR TOW DEVICE

The frame rails shall contain (6) holes per frame in a pattern specified by the OEM for mounting Spartan ERV tow eyes at the rear of the frame at a location defined by the OEM.

FRAME PAINT

The frame rails shall be hot dip galvanized prior to assembly and attachment of any components. The components that shall be galvanized shall include:

- Main frame "C" channel or channels

The frame parts which are not galvanized shall be powder coated prior to any attachment of components. Parts which shall be powder coated shall include but are not limited to:

- Steering gear bracket
- Front splayed rails and fish plates
- Bumper extensions
- Cross members
- Cross member gussets
- Fuel tank mounting brackets
- Fuel tank straps (unless material/finish is specified in 3130 subcat)
- Air tanks (unless color coded tanks are specified in 3205 subcat)
- Air tank mounting brackets
- Exhaust mounting brackets
- Air cleaner skid plate
- Radiator skid plate
- Battery supports, battery trays and battery covers

Other non-galvanized under carriage components which are received from the suppliers with coatings already applied shall include but are not limited to:

- Suspension components
- Front and rear axles

All powder coatings, primers and paint used on the non-galvanized components shall be compatible with all metals, pretreatments and primers used. The cross hatch adhesion test per ASTM D3359 shall not have a fail of more than ten (10) squares. The pencil hardness test per ASTM D3363 shall have a final post-curved pencil hardness of H-2H. The direct impact resistance test per ASTM D2794 shall have an impact resistance of 120.00 inches per pound at 2 mils.

FRAME ASSEMBLY STRUCTURAL

Purchaser shall receive a Frame Assembly Structural Fifty (50) Years or 250,000 Miles limited warranty in accordance with, and subject to, warranty certificate RFW0305. The warranty certificate is incorporated by reference into this proposal, and included with this proposal or available upon request.

FRAME RAIL CORROSION

Purchaser shall receive a Frame Rail Corrosion (Zinc Plate and Powder Coat) Twenty Five (25) Years or 150,000 Miles limited warranty in accordance with, and subject to, warranty certificate RFW0316. The warranty certificate is incorporated by reference into this proposal, and included with this proposal or available upon request.

METRO FIRE APPARATUS

FRAME COMPONENTS CORROSION

Purchaser shall receive a Frame Components Corrosion (Powder Coat) Three (3) Years or 48,000 Miles limited warranty in accordance with, and subject to, warranty certificate RFW0313. The warranty certificate is incorporated by reference into this proposal, and included with this proposal or available upon request.

REAR MUD FLAP

The unit shall be equipped with a temporary wooden fender and mud flap assembly for transport to the body manufacturer.

FRONT BUMPER

The chassis shall be equipped with a severe duty front bumper constructed from structural steel channel. The bumper material shall be 0.38 thick ASTM A36 steel which shall measure 12.00 inches high with a 3.05 inch flange and shall be 99.00 inches wide with angled front corners.

The bumper shall be primed and painted as specified.

FRONT BUMPER EXTENSION LENGTH

The front bumper shall be extended approximately 21.00 inches ahead of the cab.

FRONT BUMPER PAINT

The front bumper shall be painted the same as the lower cab color. The front bumper trim shall feature a black spray on bedliner coating.

FRONT BUMPER TRIM

A stainless steel trim angle, painted to the customer's specifications, shall be installed on the top corner of the bumper across the front and on the top corner of the bumper tails. The trim angle shall measure 1.10 inches wide on the horizontal flange and 1.60 inches tall on the vertical flange. The trim shall be affixed to the bumper, below the apron without holes and fasteners.

FRONT BUMPER APRON

The 21.00 inch extended front bumper shall include an apron constructed of 0.19 inch thick embossed aluminum tread plate.

The apron shall be installed between the bumper and the front face of the cab affixed using stainless steel bolts attaching the apron to the top bumper flange.

FRONT BUMPER COMPARTMENT CENTER

The front bumper shall include a compartment in the bumper apron located in the center between the frame rails which may be used as a hose well. The compartment shall be constructed of 0.13 inch 5052-H32 grade aluminum and shall include drain holes in the bottom corners to allow excess moisture to escape. The compartment shall be the full size of available space in the apron from the cab fascia to the bumper and 38.00 inches wide X 10.88 inches deep. The clear opening shall be 37.75 inches wide. The compartment shall include a cover constructed of 0.19 inch thick bright embossed aluminum tread plate.

METRO FIRE APPARATUS

FRONT BUMPER COMPARTMENT COVER HARDWARE

The front bumper compartment cover(s) shall include gas cylinder stays which shall hold the cover open. Each cover shall be held in the closed position via a D-ring style latch.

MECHANICAL SIREN

The front bumper shall include an electro mechanical Federal Q2B™ siren, which shall be streamlined, chrome-plated and shall produce 123 decibels of sound at 10.00 feet. The Q2B™ siren produces a distinctive warning sound that is recognizable at long distances. A unique clutch design provides a longer coast down sound while reducing the amp draw to 100 amps. The siren shall measure 10.50 inches wide X 10.00 inches high X 14.00 inches deep. The siren shall include a pedestal mount to surface mount on a horizontal surface.

MECHANICAL SIREN LOCATION

The siren shall be pedestal mounted on the bumper apron on the furthest outboard section of the bumper on the driver side.

AIR HORN

The chassis shall include two (2) Hadley brand E-Tone air horns which shall measure 24.00 inches long with a 6.00 inch round flare. The air horns shall be trumpet style with a chrome finish on the exterior and a painted finish deep inside the trumpet.

AIR HORN LOCATION

The air horns shall be recess mounted in the front bumper face, one (1) on the right side of the bumper in the outboard position relative to the right hand frame rail and one (1) on the left side of the bumper in the outboard position relative to the left hand frame rail.

AIR HORN RESERVOIR

One (1) air reservoir, with a 2084 cubic inch capacity, shall be installed on the chassis to act as a supply tank for operating air horns. The reservoir shall be isolated with a 90 PSI pressure protection valve on the reservoir supply side to prevent depletion of the air to the air brake system.

ELECTRONIC SIREN SPEAKER

There shall be two (2) Cast Products Inc. model SA4301, 100 watt speakers provided. Each speaker shall measure 6.20 inches tall X 7.36 inches wide X 3.06 inches deep. Each speaker shall include a flat mounting flange which shall be polished aluminum.

ELECTRONIC SIREN SPEAKER LOCATION

The two (2) electronic siren speakers shall be located on the front bumper face outboard of the frame rails with one (1) on the right side and one (1) on the left side in the inboard positions.

FRONT BUMPER TOW HOOKS

Two (2) heavy duty tow hooks, painted to match the frame components, shall be installed below the front bumper in the forward position, bolted directly to the underside of each chassis frame rail with grade 8 bolts.

METRO FIRE APPARATUS

CAB TILT SYSTEM

The entire cab shall be capable of tilting approximately 45-degrees to allow for easy maintenance of the engine and transmission. The cab tilt pump assembly shall be located on the right side of the chassis above the battery box.

The electric-over-hydraulic lift system shall include an ignition interlock and red cab lock down indicator lamp on the tilt control which shall illuminate when holding the "Down" button to indicate safe road operation.

It shall be necessary to activate the master battery switch and set the parking brake in order to tilt the cab. As a third precaution the ignition switch must be turned off to complete the cab tilt interlock safety circuit.

Two (2) spring-loaded hydraulic hold down hooks located outboard of the frame shall be installed to hold the cab securely to the frame. Once the hold-down hooks are set in place, it shall take the application of pressure from the hydraulic cab tilt lift pump to release the hooks.

Two (2) cab tilt cylinders shall be provided with velocity fuses in each cylinder port. The cab tilt pivots shall be 1.90 inch ball and be anchored to frame brackets with 1.25 inch diameter studs.

A steel safety channel assembly, painted safety yellow shall be installed on the right side cab lift cylinder to prevent accidental cab lowering. The safety channel assembly shall fall over the lift cylinder when the cab is in the fully tilted position. A cable release system shall also be provided to retract the safety channel assembly from the lift cylinder to allow the lowering of the cab.

CAB TILT AUXILIARY PUMP

A manual cab tilt pump module shall be attached to the cab tilt pump housing.

CAB TILT LIMIT SWITCH

A cab tilt limit switch shall be installed. The switch will effectively limit the travel of the cab when being tilted. The limit adjustment of the switch shall be preset by the chassis manufacturer to prevent damage to the cab or any bumper mounted option mounted in the cab tilt arc. Further adjustment to the limit by the apparatus manufacturer shall be available to accommodate additional equipment.

CAB TILT CONTROL RECEPTACLE

A 25.00 foot cab tilt control harness shall be provided on the right side of frame just behind the cab. This harness shall consist of an 8.00 foot harness connected to the tilt pump and a 17.00 foot extension harness with a six (6) pin Deutsch connector with cap for mounting in a compartment in the body.

The remote control pendant shall include 20.00 feet of cable with a mating Deutsch connector. The remote control pendant shall be shipped loose with the chassis.

CAB TILT LOCK DOWN INDICATOR

The cab dash shall include a message located within the dual air pressure gauge which shall alert the driver when the cab is unlocked and ajar. The alert message shall cease to be displayed when the cab is in the fully lowered position and the hold down hooks are secured and locked to the cab mounts.

In addition to the alert message an audible alarm shall sound when the cab is unlocked and ajar with the parking brake released.

METRO FIRE APPARATUS

CAB WINDSHIELD

The cab windshield shall have a surface area of 2825.00 square inches and be of a two (2) piece wraparound design for maximum visibility.

The glass utilized for the windshield shall include standard automotive tint. The left and right windshield shall be fully interchangeable thereby minimizing stocking and replacement costs.

Each windshield shall be installed using black self locking window rubber.

GLASS FRONT DOOR

The front cab doors shall include a window which is 27.00 inches in width X 26.00 inches in height. These windows shall have the capability to roll down completely into the door housing. This shall be accomplished using electric actuation. The left and right front door windows shall be controlled using a switch on each respective side inner door panel. The driver's door shall include a switch for each powered door window in the cab.

There shall be an irregular shaped fixed window which shall measure 2.50 inches wide at the top, 8.00 inches wide at the bottom X 26.00 inches in height, more commonly known as "cozy glass" ahead of the front door roll down windows.

The windows shall be mounted within the frame of the front doors trimmed with a black anodized ring on the exterior.

GLASS TINT FRONT DOOR

The windows located in the left and right front doors shall include a dark gray automotive tint which shall allow forty-five percent (45%) light transmittance. The dark tint shall aid in cab cooling and help protect passengers from radiant solar energy.

GLASS REAR DOOR RH

The rear right hand side crew door shall include a window which is 27.00 inches in width X 26.00 inches in height. The window shall be a powered type and shall be controlled by a switch on the door panel ledge and on the driver's control panel.

GLASS TINT REAR DOOR RIGHT HAND

The window located in the right hand side rear window shall include a dark gray automotive tint which shall allow forty-five percent (45%) light transmittance. The dark tint shall aid in cab cooling and help protect passengers from radiant solar energy.

GLASS REAR DOOR LH

The rear left hand side crew door shall include a window which is 27.00 inches in width X 26.00 inches in height. The window shall be a powered type and shall be controlled by a switch on the door panel ledge and on the driver's control panel.

GLASS TINT REAR DOOR LEFT HAND

The window located in the left hand side rear door shall include a dark gray automotive tint which shall allow forty-five percent (45%) light transmittance. The dark tint shall aid in cab cooling and help protect passengers from radiant solar energy.

METRO FIRE APPARATUS

GLASS SIDE MID RH

The cab shall include a window on the right side behind the front and ahead of the crew door which shall measure 16.00 inches wide X 26.00 inches high. This window shall be fixed within this space and shall be rectangular in shape. The window shall be mounted using self locking window rubber. The glass utilized for this window shall include a green automotive tint unless otherwise noted.

GLASS TINT SIDE MID RIGHT HAND

The window located on the right hand side of the cab between the front and rear doors shall include a dark gray automotive tint which shall allow forty-five percent (45%) light transmittance. The dark tint shall aid in cab cooling and help protect passengers from radiant solar energy.

GLASS SIDE MID LH

The cab shall include a window on the left side behind the front door and ahead of the crew door and above the wheel well which shall measure 16.00 inches wide X 26.00 inches high. This window shall be fixed within this space and shall be rectangular in shape. The window shall be mounted using self locking window rubber. The glass utilized for this window shall include a green automotive tint unless otherwise noted.

GLASS TINT SIDE MID LEFT HAND

The window located on the left hand side of the cab between the front and rear doors shall include a dark gray automotive tint which shall allow forty-five percent (45%) light transmittance. The dark tint shall aid in cab cooling and help protect passengers from radiant solar energy.

CLIMATE CONTROL

A ceiling mounted combination defroster and cabin heating and air conditioning system shall be located above the engine tunnel area. The system covers and plenums shall be of severe duty design made of aluminum which shall be coated with a customer specified interior paint. The design of the system's covers shall provide quick access to washable air intake filters as well as easy access to other serviceable items.

The air delivery plenums provide targeted airflow directly to the vehicle occupants. Six (6) adjustable louvers will provide comfort for the front seat occupants and ten (10) adjustable louvers will provide comfort for the rear crew occupants.

The system shall be capable of producing up to 12 FPM of air velocity at all occupant seating positions. Separate front and rear blower motors shall be of brushless design and shall be controlled independently. It shall be capable of reducing the interior cabin air temperature from 122° F (+/- 3° F) to 80° F in thirty minutes with 50% relative humidity and full solar load as described in SAE J2646.

The system shall also provide heater pull up performance which meets or exceeds the performance requirements of SAE J1612 as well as defrost performance that meets or exceeds the performance requirements of SAE J381.

A gravity drain system shall be provided that is capable of evacuating condensate from the vehicle while on a slope of up to a 13% grade in any direction.

The air conditioning system plumbing shall be a mixture of custom bent zinc coated steel fittings and Aeroquip flexible hose with Aeroquip EZ-Clip fittings.

The overhead heater/defroster plumbing shall include an electronic flow control valve that re-directs hot coolant away from the evaporator, via a bypass loop, as the temperature control is moved toward the cold position.

METRO FIRE APPARATUS

Any component which needs to be accessed to perform system troubleshooting shall be accessible by one person using basic hand tools. Regularly serviced items shall be replaceable by one person using basic hand tools.

*****The chassis manufacturer recommends that the overall climate system performance be based off third-party testing in accordance with the Society of Automotive Engineering standards as a complete system.***

Individual component level BTU ratings is not an accurate indicator of the performance capability of the completed system. System individual component BTU ratings:

- Air conditioning evaporator total BTU/HR: 82,000
- Air conditioning condenser total BTU/HR: 59,000
- Heater coil total BTU/HR: 98,000

Performance data specified is based on testing performed by an independent third-party test facility using a medium four-door 10" raised roof cab equipped with an ISL engine.

CLIMATE CONTROL DRAIN

The climate control system shall include a gravity drain for water management. The gravity drain shall remove condensation from the air conditioning system without additional mechanical assistance.

CLIMATE CONTROL ACTIVATION

The heating, defrosting and air conditioning controls shall be in the center dash center switch panel, in a position which is easily accessible to the driver. The climate control shall be activated by a rotary switch.

HVAC OVERHEAD COVER PAINT

The overhead HVAC cover shall be painted with a multi-tone silver gray texture finish.

A/C CONDENSER LOCATION

A roof mounted A/C condenser shall be installed centered on the cab forward of the raised roof against the slope rise.

A/C COMPRESSOR

The air-conditioning compressor shall be a belt driven, engine mounted compressor. The compressor shall be compatible with R134-a refrigerant.

*****The chassis manufacturer recommends that the overall climate system performance be based off third-party testing in accordance with the Society of Automotive Engineering standards as a complete system.***

Individual component level ratings are not an accurate indicator of the performance capability of the completed system.

Refrigerant Compressor displacement: 19.1 cubic inches per revolution.

UNDER CAB INSULATION

The underside of the cab tunnel surrounding the engine shall be lined with multi-layer insulation, engineered for application inside diesel engine compartments.

The insulation shall act as a noise barrier, absorbing noise thus keeping the decibel level in the cab well within NFPA recommendations. As an additional benefit, the insulation shall assist in sustaining the desired temperature within the cab interior.

METRO FIRE APPARATUS

The engine tunnel insulation shall measure approximately 0.30 inch thick including a multi-layer foil faced glass cloth and polyester fiber layer. The foil surface acts as protection against heat, moisture and other contaminants. The insulation shall meet or exceed FMVSS 302 flammability test.

The cab floor insulation shall measure 0.56 inch thick including a 1.0#/sf PVC barrier and a moisture and heat reflective foil facing, reinforced with fiberglass strands. The foil surface acts as protection against moisture and other contaminants. The insulation shall meet or exceed FMVSS 302 flammability test.

The insulation shall be cut precisely to fit each section and sealed for additional heat and sound deflection. The insulation shall be held in place by acrylic pressure sensitive adhesive. In addition, the insulation on the underside of the cab floor shall have aluminum pins with hard hat, hold in place fastening heads and an expanded metal overlay to assist in retaining the insulation tight against the cab. The insulation inside the tunnel shall have a removable aluminum overlay installed to protect the insulation and assist in retaining the insulation tight against the engine tunnel surfaces.

The cab floor insulation shall cover the driver and officer floor areas as well as all crew floor areas and compartment floor areas if applicable.

INTERIOR TRIM FLOOR

The floor of the cab shall be covered with a multi-layer mat consisting of 0.25 inch thick sound absorbing closed cell foam with a 0.06 inch thick non-slip vinyl surface with a pebble grain finish. The covering shall be held in place by a pressure sensitive adhesive and embossed treadplate trim that shall wrap 2" horizontally and vertically. All exposed seams shall be sealed with silicone caulk matching the color of the floor mat to reduce the chance of moisture and debris retention.

INTERIOR TRIM

The cab interior shall include trim on the front ceiling, rear crew ceiling, and the cab walls. It shall be easily removable to assist in maintenance. The trim shall be constructed of insulated vinyl over a hard board backing.

REAR WALL INTERIOR TRIM

The rear wall of the cab shall be trimmed with vinyl.

HEADER TRIM

The cab interior shall feature header trim over the driver and officer dash constructed of 5052-H32 Marine Grade, 0.13 inch thick aluminum.

TRIM CENTER DASH

The main center dash area shall be constructed of 5052-H32 Marine Grade, 0.13 inch thick aluminum plate. There shall be four (4) holes located on the top of the dash near each outer edge of the electrical access cover for ventilation. The center dash electrical access cover shall include a gas cylinder stay which shall hold the cover open during maintenance.

TRIM LH DASH

The left hand dash shall be constructed of 5052-H32 Marine Grade, 0.13 inch thick aluminum plate for a perfect fit around the instrument panel. For increased occupant protection the extreme duty left hand dash utilizes patent pending break away technology to reduce rigidity in the event of a frontal crash. The left hand dash shall offer lower vertical surface area to the left and right of the steering column to accommodate control panels.

METRO FIRE APPARATUS

TRIM RH DASH

The right hand dash shall be constructed of 5052-H32 Marine Grade, 0.13 of an inch thick aluminum plate and shall include a glove compartment with a hinged door and a Mobile Data Terminal (MDT) provision. The glove compartment size will measure 14.00 inches wide X 6.38 inches high X 5.88 inches deep. The MDT provision shall be provided above the glove compartment.

ENGINE TUNNEL TRIM

The cab engine tunnel shall be covered with a multi-layer mat consisting of 0.25 inch closed cell foam with a 0.06 inch thick non-slip vinyl surface with a pebble grain finish. The mat shall be held in place by pressure sensitive adhesive. The engine tunnel mat shall be trimmed with anodized aluminum stair nosing trim for an aesthetically pleasing appearance.

POWER POINT DASH MOUNT

The cab interior shall include (2) Blue Sea dual universal serial bus (USB) charging receptacles in the cab dash switch panel to provide a power source for USB chargeable electrical equipment. The USB port shall be capable of a 5 Volt-4.8 amp total output. The receptacles shall be wired battery direct.

STEP TRIM

Each cab entry door shall include a three step entry. The first step closest to the ground shall be constructed of SAE 304 stainless steel with embossed perforations and diamond shaped cutout. The perforations and cutouts shall allow water and other debris to flow through rather than becoming trapped within the stepping surface. The step shall feature a splash guard to reduce water and debris from splashing in to the step. The splash guard shall have drainage holes beneath the back of the step to allow debris and water to flow through rather than becoming trapped within the stepping surface. The stainless steel material shall have a number 8 mirror finish. The lower step shall be mounted to a frame which is integral with the construction of the cab for rigidity and strength. The middle step shall be integral with the cab construction and shall be trimmed in 0.08 inch thick 3003-H22 embossed aluminum tread plate.

STEP TRIM KICKPLATE

The cab steps shall include a kick plate in the rise of each step. The risers shall be trimmed in 3003-H22 bright aluminum tread-plate which is 0.07 inch thick.

UNDER CAB ACCESS DOOR

The cab shall include an aluminum access door in the left crew step riser painted to match the cab interior paint with a push and turn latch. The under cab access door shall provide access to the diesel exhaust fluid fill.

INTERIOR DOOR TRIM

The interior trim on the doors of the cab shall consist of an aluminum panel constructed of Marine Grade 5052-H32 0.13 of an inch thick aluminum plate. The door panels shall include a painted finish.

DOOR TRIM CUSTOMER NAMEPLATE

The interior door trim on the front doors shall include a customer nameplate which states the vehicle was custom built for their Department.

METRO FIRE APPARATUS

CAB DOOR TRIM REFLECTIVE

In accordance with the current standards of NFPA, the body builder shall provide 96.00 square inches of reflective material on the interior of each cab door.

INTERIOR GRAB HANDLE "A" PILLAR

There shall be two (2) rubber covered 11.00 inch grab handles installed inside the cab, one on each "A" post at the left and right door openings. The left handle shall be located 7.88 inches above the bottom of the door window opening and the right handle shall be located 2.88 inches above the bottom of the door window opening. The handles shall assist personnel in entering and exiting the cab.

INTERIOR GRAB HANDLE FRONT DOOR

Each front door shall include one (1) ergonomically contoured 9.00 inch cast aluminum handle mounted horizontally on the interior door panels. The handles shall feature a DA sand finish to assist personnel entering and exiting the cab.

INTERIOR GRAB HANDLE REAR DOOR

A DA sanded cast aluminum assist handle shall be provided on the inside of each rear crew door. A 30.00 inch long handle shall extend horizontally the width of the window just above the window sill. The handle shall assist personnel in exiting and entering the cab.

INTERIOR SOFT TRIM COLOR

The cab interior soft trim surfaces shall be gray in color.

INTERIOR TRIM SUNVISOR

The header shall include two (2) sun visors, one each side forward of the driver and officer seating positions above the windshield. Each sun visor shall be constructed of Masonite and covered with padded vinyl trim.

INTERIOR FLOOR MAT COLOR

The cab interior floor mat shall be gray in color.

CAB PAINT INTERIOR

The inner door panel surfaces shall feature a medium gray spray on bedliner coating.

HEADER TRIM INTERIOR PAINT

The metal surfaces in the header area shall feature a medium gray spray on bedliner coating.

TRIM CENTER DASH INTERIOR PAINT

The entire center dash and any accessory pods attached to the dash shall feature a medium gray spray on bedliner coating.

TRIM LEFT HAND DASH INTERIOR PAINT

The left hand dash shall feature a medium gray spray on bedliner coating.

METRO FIRE APPARATUS

TRIM RIGHT HAND DASH INTERIOR PAINT

The right hand dash shall feature a medium gray spray on bedliner coating.

DASH PANEL GROUP

The main center dash area shall include three (3) aluminum removable panels located one (1) to the right of the driver position, one (1) in the center of the dash and one (1) to the left of the officer position. The panels shall be coated with a black texture finish. The center panel shall be within comfortable reach of both the driver and officer.

SWITCHES CENTER PANEL

The center dash panel shall include no rocker switches or legends.

SWITCHES LEFT PANEL

The left dash panel shall include one (1) windshield wiper/washer control switch located in the left hand side of the panel. The switch shall have backlighting provided.

SWITCHES RIGHT PANEL

The right dash panel shall six (6) rocker switch positions in a three (3) over three (3) switch configuration.

A rocker switch with a blank legend installed directly above shall be provided for any position without a switch and legend designated by a specific option. The non-specified switches shall be two-position, black switches with a green indicator light. Each blank switch legend can be custom engraved by the body manufacturer. All switch legends shall have backlighting provided.

SEAT BELT WARNING

A Weldon seat belt warning system, integrated with the Vehicle Data Recorder system, shall be installed for each seat within the cab. The system shall provide a visual warning indicator in the vehicle display and control screen(s) and a fast tone audible alarm. The wiring connections at each seat shall have heat shrink tubing applied so that the wiring cannot be easily disconnected to disable the system.

The warning system shall activate when any seat is occupied with a minimum of 60 pounds, the corresponding seat belt remains unfastened, and the park brake is released. The warning system shall also activate when any seat is occupied, the corresponding seat belt was fastened in an incorrect sequence, and the park brake is released. Once activated, the visual indicators and applicable audible alarm shall remain active until all occupied seats have the seat belts fastened.

SEAT MATERIAL

The Bostrom Firefighter seats shall include a covering of extra high strength, wear resistant fabric made of durable low seam Durawear Plus™ ballistic polyester. A PVC coating shall be bonded to the back side of the material to help protect the seats from UV rays and from being saturated or contaminated by fluids. Durawear Plus™ meets or exceeds specification of the common trade name Imperial 1800. The material meets FMVSS 302 flammability requirements.

If applicable, Theatre style seats located in the cab shall be high strength, wear resistant fabric made of durable ballistic polyester. A PVC coating shall be bonded to the back side of the material to help protect the seats from UV rays and from being saturated or contaminated by fluids. Common trade names for this material are Imperial 1200 and Durawear.

METRO FIRE APPARATUS

SEAT COLOR

All seats supplied with the chassis shall be gray in color. All seats shall include red seat belts.

SEAT BACK LOGO

The seat back shall include the "Spartan" logo. The logo shall be centered on the standard headrest of the seat back and on the left side of a split headrest.

SEAT DRIVER

The driver's seat shall be an H.O. Bostrom 500 Series Firefighter Sierra model seat. The seat shall feature eight-way electric positioning. The eight positions shall include up and down, fore and aft, back angle adjustment and seat rake adjustment. The seat shall feature integral springs to isolate shock. The fore and aft travel shall be limited as required due to customer selected items such as axillary air compressors, battery conditioners and their specified locations.

The seat shall feature an all belts to seat (ABTS) style of safety restraint. The ABTS feature shall include a three-point shoulder harness with the lap belt, automatic retractor and buckle as an integral part of the seat assembly. The ABTS feature shall also include the RiteHite™ shoulder adjustment feature to provide enhanced comfort and safety by allowing customized seat belt fit.

The minimum vertical dimension from the seat H-point to the ceiling for this belted seating position shall be 35.00 inches measured with the seat height adjusted to the lowest position of travel.

This model of seat shall have successfully completed the static load tests set forth by FMVSS 207, 209, and 210 in effect at the time of manufacture. This testing shall include a simultaneous forward load of 3000 pounds each on the lap and shoulder belts and twenty (20) times the weight through the center of gravity.

The materials used in construction of the seat shall also have successfully completed testing with regard to the flammability of materials used in the occupant compartments of motor vehicles as outlined in FMVSS 302, of which dictates the allowable burning rate of materials in the occupant compartments of motor vehicles.

SEAT BACK DRIVER

The driver's seat shall include a standard seat back incorporating the all belts to seat feature (ABTS). The seat back shall feature a contoured head rest.

SEAT MOUNTING DRIVER

The driver's seat shall be installed in an ergonomic position in relation to the cab dash.

SEAT OFFICER

The officer's seat shall be a H.O. Bostrom 500 Series Sierra seat model. The seat shall feature a tapered and padded seat, and cushion. The seat shall be mounted in a fixed position.

The seat shall feature an all belts to seat (ABTS) style of safety restraint. The ABTS feature shall include a three-point shoulder harness with the lap belt and automatic retractor as an integral part of the seat assembly. The buckle portion of the seat belt shall extend from the seat base towards the driver position within easy reach of the occupant. The ABTS feature shall also include the RiteHite™ shoulder adjustment feature to provide enhanced comfort and safety by allowing customized seat belt fit.

The minimum vertical dimension from the seat H-point to the ceiling for this belted seating position shall be 35.00 inches.

METRO FIRE APPARATUS

This model of seat shall have successfully completed the static load tests by FMVSS 207/210. This testing shall include a simultaneous forward load of 3000 pounds each on the lap and shoulder belts and twenty (20) times the weight through the center of gravity. This model of seat installed in the cab model, as specified, shall have successfully completed the dynamic sled testing using FMVSS 208 as a guide with the following accommodations. In order to reflect the larger size outfitted firefighters, the test dummy used shall be a 95th percentile hybrid III male weighing 225 pounds rather than the 50th percentile male dummy weighing 165 pounds as referenced in FMVSS 208. The model of seats shall also have successfully completed the flammability of materials used in the occupant compartments of motor vehicles as outlined in FMVSS 302, of which decides the burning rate of materials in the occupant compartments of motor vehicles.

SEAT BACK OFFICER

The officer's seat back shall include an IMMI brand SmartDock® Gen 2 hands-free self contained breathing apparatus (SCBA) holder. The hands-free holder shall meet NFPA 1901-03 9G dynamic requirements for cylinder restraint systems for use in crew compartments of emergency response vehicles. The bracket shall accommodate and secure most types of self-contained breathing apparatus cylinders.

The hands-free holder shall consist of a back plate, bottom cradle, non-marring top claws, and claw height adjustment knob. The height adjustment knob shall allow for easy adjustment of the claws to the SCBA. The hands-free holder's claws shall lock from inertial forces to prevent the SCBA from becoming a projectile in the event of a crash to meet the NFPA 1901-03 standard for SCBA retention. The SCBA holder shall offer single-motion insertion into the claws and hands-free release when the SCBA fitted seat occupant rises.

The seat back shall include a removable padded cover which shall be provided over the SCBA cavity.

SEAT MOUNTING OFFICER

The officer's seat shall offer a special mounting position which is approximately 2.50 inches rearward of the standard location offering increased leg room for the occupant. The front face of the officer's under seat storage box shall be modified 8.13 inches rearward for floor storage below the seat eliminating the under seat storage compartment and access door.

POWER SEAT WIRING

The power seat or seats installed in the cab shall be wired directly to battery power.

SEAT BELT ORIENTATION CREW

The crew position seat belts shall follow the standard orientation which extends from the outboard shoulder extending to the inboard hip.

SEAT FORWARD FACING OUTER LOCATION

The crew area shall include two (2) forward facing outboard seats, which include one (1) located next to the outer wall of the cab on the left side of the cab and one (1) located next to the outer wall on the right side of the cab.

SEAT CREW FORWARD FACING OUTER

The crew area shall include a seat in the forward facing outer position which shall be a H.O. Bostrom 500 Series Firefighter model seat. The seat shall feature a tapered and padded seat, and cushion. The seat shall be mounted in a fixed position. The seat and cushion shall be hinged and compact in design for additional room. The seat shall include a "Fold and Hold" feature so that the cushion shall remain in the seated position and simply touched to flip up.

METRO FIRE APPARATUS

The seat shall feature an all belts to seat (ABTS) style of safety restraint. The ABTS feature shall include a three-point shoulder harness with the lap belt and automatic retractor as an integral part of the seat assembly. The buckle portion of the seat belt shall extend from the seat base towards the driver position within easy reach of the occupant. The ABTS feature shall also include the RiteHite™ shoulder adjustment feature to provide enhanced comfort and safety by allowing customized seat belt fit.

The minimum vertical dimension from the seat H-point to the ceiling for each belted seating position shall be 35.00 inches.

This model of seat shall have successfully completed the static load tests by FMVSS 207/210. This testing shall include a simultaneous forward load of 3000 pounds each on the lap and shoulder belts and twenty (20) times the weight through the center of gravity. This model of seat installed in the cab model, as specified, shall have successfully completed the dynamic sled testing using FMVSS 208 as a guide with the following accommodations. In order to reflect the larger size outfitted firefighters, the test dummy used shall be a 95th percentile hybrid III male weighing 225 pounds rather than the 50th percentile male dummy weighing 165 pounds as referenced in FMVSS 208. The model of seats shall also have successfully completed the flammability of materials used in the occupant compartments of motor vehicles as outlined in FMVSS 302, of which decides the burning rate of materials in the occupant compartments of motor vehicles.

SEAT BACK FORWARD FACING OUTER

The crew area seat backs shall include an IMMI brand SmartDock® Gen 2 hands-free self contained breathing apparatus (SCBA) holder. The hands-free holder shall meet NFPA 1901-03 9G dynamic requirements for cylinder restraint systems for use in crew compartments of emergency response vehicles. The bracket shall accommodate and secure most types of self-contained breathing apparatus cylinders.

The hands-free holder shall consist of a back plate, bottom cradle, non-marring top claws, and claw height adjustment knob. The height adjustment knob shall allow for easy adjustment of the claws to the SCBA. The hands-free holder's claws shall lock from inertial forces to prevent the SCBA from becoming a projectile in the event of a crash to meet the NFPA 1901-03 standard for SCBA retention. The SCBA holder shall offer single-motion insertion into the claws and hands-free release when the SCBA fitted seat occupant rises.

The seat back shall include a removable padded cover which shall be provided over the SCBA cavity.

SEAT MOUNTING FORWARD FACING OUTER

The forward facing outer seat shall be mounted inboard from the side wall for additional clearance facing the front of the cab.

SEAT FORWARD FACING CENTER LOCATION

The crew area shall include one (1) forward facing center crew seat located directly behind the engine tunnel in the center of the cab.

SEAT CREW FORWARD FACING CENTER

The forward facing center seat shall be a H.O. Bostrom 500 Series Firefighter model seat. The seat shall feature a tapered and padded seat, and cushion. The seat shall be mounted in a fixed position. The seat and cushion shall be hinged and compact in design for additional room. The seat shall include a "Fold and Hold" feature so that the cushion shall remain in the seated position and simply touched to flip up.

The seat shall feature an all belts to seat (ABTS) style of safety restraint. The ABTS feature shall include a three-point shoulder harness with the lap belt and automatic retractor as an integral part of the seat assembly. The buckle portion of the seat belt shall extend from the seat base towards the driver position within easy reach of the occupant. The ABTS

METRO FIRE APPARATUS

feature shall also include the RiteHite™ shoulder adjustment feature to provide enhanced comfort and safety by allowing customized seat belt fit.

The minimum vertical dimension from the seat H-point to the ceiling for each belted seating position shall be 35.00 inches.

This model of seat shall have successfully completed the static load tests by FMVSS 207/210. This testing shall include a simultaneous forward load of 3000 pounds each on the lap and shoulder belts and twenty (20) times the weight through the center of gravity. This model of seat installed in the cab model, as specified, shall have successfully completed the dynamic sled testing using FMVSS 208 as a guide with the following accommodations. In order to reflect the larger size outfitted firefighters, the test dummy used shall be a 95th percentile hybrid III male weighing 225 pounds rather than the 50th percentile male dummy weighing 165 pounds as referenced in FMVSS 208. The model of seats shall also have successfully completed the flammability of materials used in the occupant compartments of motor vehicles as outlined in FMVSS 302, of which decides the burning rate of materials in the occupant compartments of motor vehicles.

SEAT BACK FORWARD FACING CENTER

The crew area seat backs shall include an IMMI brand SmartDock® Gen 2 hands-free self contained breathing apparatus (SCBA) holder. The hands-free holder shall meet NFPA 1901-03 9G dynamic requirements for cylinder restraint systems for use in crew compartments of emergency response vehicles. The bracket shall accommodate and secure most types of self-contained breathing apparatus cylinders.

The hands-free holder shall consist of a back plate, bottom cradle, non-marring top claws, and claw height adjustment knob. The height adjustment knob shall allow for easy adjustment of the claws to the SCBA. The hands-free holder's claws shall lock from inertial forces to prevent the SCBA from becoming a projectile in the event of a crash to meet the NFPA 1901-03 standard for SCBA retention. The SCBA holder shall offer single-motion insertion into the claws and hands-free release when the SCBA fitted seat occupant rises.

The seat back shall include a removable padded cover which shall be provided over the SCBA cavity.

SEAT FRAME FORWARD FACING

The forward facing center seating positions shall include an enclosed style seat frame located and installed at the rear wall. The seat frame shall measure 62.38 inches wide X 12.38 inches high X 22.00 inches deep. The seat frame shall be constructed of Marine Grade 5052-H32 0.19 inch thick aluminum plate. The forward corners of the bench shall be chamfered 45-degrees X 4.00 inches.

SEAT FRAME FORWARD FACING STORAGE ACCESS

There shall be two (2) access points to the storage area centered on the front of the seat frame. Each access point shall be covered by a hinged door to allow access for storage in the seat box.

SEAT MOUNTING FORWARD FACING CENTER

The forward facing center seats shall be installed facing the front of the cab.

CAB FRONT UNDERSEAT STORAGE ACCESS DOOR

The left under seat storage area shall have a solid aluminum hinged door with non-locking latch.

SEAT COMPARTMENT DOOR FINISH

All underseat storage compartment access doors shall feature a medium gray spray on bedliner coating.

METRO FIRE APPARATUS

WINDSHIELD WIPER SYSTEM

The cab shall include a triple arm linkage wiper system which shall clear the windshield of water, ice and debris. There shall be two (2) windshield wipers; each shall be affixed to a radial arm. The wiper motor shall be activated by an intermittent wiper control located within easy reach of the driver's position. The windshield wipers shall be interlocked with the park brake allowing activation only when the park brake is released.

ELECTRONIC WINDSHIELD FLUID LEVEL INDICATOR

The windshield washer fluid level shall be monitored electronically. When the washer fluid level becomes low the yellow "Check Message Center" indicator light on the instrument panel shall illuminate and the message center in the dual air pressure gauge shall display a "Check Washer Fluid Level" message.

CAB DOOR HARDWARE

The cab entry doors shall be equipped with exterior pull handles, suitable for use while wearing firefighter gloves. The handles shall be made of aluminum with a chrome plated finish.

The interior exit door handles shall be flush paddle type with a black finish, which are incorporated into the upper door panel.

All cab entry doors shall include locks which are keyed alike. The door locks shall be designed to prevent accidental lockout.

DOOR LOCKS

The cab entry doors shall include a Controller Area Network (CAN) based electronic door lock system which shall include two (2) external keypads, one (1) located on the left side next to the front grab handle and one (1) on the right side next to the front grab handle. There shall be one (1) red rocker switch provided on the inside of each front cab entry door to actuate the cab door locks. Each door lock may also be manually actuated from the inside of the cab by means of a red knob located on the paddle handle of the respective door. The electronic door lock system shall include four (4) key fobs for actuation with buttons for cab entry door locks and for compartment door locks.

When the doors are unlocked using the external keypad or the key fobs the interior dome lights shall illuminate and remain on for a period of twenty (20) seconds. The interior dome safety feature shall require the interior lighting power to be battery direct.

Wiring shall also be provided for up to four (4) exterior cab compartments and up to four (4) body compartments.

POWER DOOR LOCK COMPARTMENT ACTIVATION

The power door lock feature shall include activation for exterior compartment door locks through the key fob and keypads.

GRAB HANDLES

The cab shall include one (1) 18.00 inch three-piece knurled aluminum anti-slip exterior grab handle behind each cab door. The Hansen Anti-Slip Rails shall be mounted in bright anodized aluminum 4000 Series II stanchions, complete with weep holes to prevent the buildup of moisture.

The grab rails shall include red reflective tape.

METRO FIRE APPARATUS

LIGHTED GRAB HANDLES

The grab rails shall include a 12 volt, 17.00 inch long clear LED light to provide an increased margin of safety for night time cab entry and egress.

REARVIEW MIRRORS

Retrac Aerodynamic West Coast style dual vision mirror heads model 613305 shall be provided and installed on each of the front cab doors.

The mirrors shall be mounted via 1.00 inch diameter tubular stainless steel arms to provide a rigid mounting to reduce mirror vibration.

The mirrors shall measure 8.00 inches wide X 19.00 inches high and shall include an integral convex mirrors installed in the mirror head below the flat glass to provide a wider field of vision. The flat and convex mirrors shall be motorized with remote horizontal and vertical adjustment. The control switches shall be mounted within easy reach of the driver. The flat and convex mirrors shall be heated for defrosting in severe cold weather conditions.

The mirrors shall be constructed of a vacuum formed chrome plated ABS plastic housing that is corrosion resistant and shall include the finest quality non-glare glass.

REARVIEW MIRROR HEAT SWITCH

The heat for the rearview mirrors shall be controlled through a virtual button on the Vista display and control screen.

TRIM REAR WALL EXTERIOR

The exterior rear wall of the cab shall include an overlay of 3003-H22 aluminum tread plate which shall be 0.07 inches thick. This overlay shall cover the entire rear wall of the cab.

CAB FENDER

Full width wheel well liners shall be installed on the extruded cab to limit road splash and enable easier cleaning. Fender shall consist of an inner liner 16.00 inches wide made of ABS composite and an outer fenderette 5.00 inches wide made of SAE 304 polished stainless steel.

MUD FLAPS FRONT

The front wheel wells shall have mud flaps installed on them.

CAB EXTERIOR FRONT & SIDE EMBLEMS

The cab shall include three (3) Spartan emblems. There shall be one (1) installed on the front air intake grille and one (1) emblem on each of the cab sides.

IGNITION

A master battery system with a keyless start ignition system shall be provided. There shall be a three-position rocker switch with off, battery, and ignition positions as well as a stainless-steel etched engine start push-button. The engine start button shall include an illuminated LED halo ring. Both switches shall be mounted to the left of the steering wheel on the dash.

The engine start switch shall only operate when the master battery and ignition switch is in the "ignition" position.

METRO FIRE APPARATUS

BATTERY

The single start electrical system shall include six (6) Harris BCI 31 925 CCA batteries with a 210 minute reserve capacity and 4/0 welding type dual path starter cables per SAE J541.

BATTERY TRAY

The batteries shall be installed within two (2) steel battery trays located on the left side and right side of the chassis, securely bolted to the frame rails. The battery trays shall be coated with the same material as the frame.

The battery trays shall include drain holes in the bottom for sufficient drainage of water. A durable, non-conducting, interlocking mat made by Dri-Dek shall be installed in the bottom of the trays to allow for air flow and help prevent moisture build up. The batteries shall be held in place by non-conducting phenolic resin hold down boards.

BATTERY BOX COVER

Each battery box shall include a steel cover which protects the top of the batteries. Each cover shall include flush latches which shall keep the cover secure as well as a black powder coated handle for convenience when opening.

BATTERY CABLE

The starting system shall include cables which shall be protected by 275 degree F. minimum high temperature flame retardant loom, sealed at the ends with heat shrink and sealant.

BATTERY JUMPER STUD

The starting system shall include battery jumper studs. These studs shall be located in the forward most portion of the driver's side lower step, 8.00 inches apart. The studs shall allow the vehicle to be jump started, charged, or the cab to be raised in an emergency in the event of battery failure.

ALTERNATOR

The charging system shall include a 320 amp Leece-Neville 12 volt alternator. The alternator shall include a self-exciting integral regulator.

STARTER MOTOR

The single start electrical system shall include a Delco brand starter motor.

BATTERY CONDITIONER

A Kussmaul Auto Charge Chief 4012 battery conditioner shall be supplied. The battery conditioner shall provide a 40 amp output for the chassis batteries and a 20 amp output circuit for accessory loads. The battery conditioner shall be mounted in the cab in the LH rear facing outer seating position and shall include a battery temperature sensor.

BATTERY CONDITIONER DISPLAY

A Kussmaul universal status center battery conditioner display shall be supplied. The display shall indicate full charge, low charge, charging, and a three (3) digit voltage reading. The battery conditioner display shall be mounted in front of the left side door just below the windshield.

ELECTRICAL INLET LOCATION

An electrical inlet shall be installed on the left hand side of cab over the wheel well.

METRO FIRE APPARATUS

ELECTRICAL INLET

A Kussmaul 20 amp super auto-eject electrical receptacle shall be supplied. It shall automatically eject the plug when the starter button is depressed.

A single item or an addition of multiple items must not exceed the rating of the electric inlet that it's connected to.

Amp Draw Reference List:

Kussmaul 40 LPC Charger - 5 Amps
Kussmaul 40/20 Charger - 8.5 Amps
Kussmaul 80 LPC Charger - 13 Amps
Kussmaul EV-40 - 6.2 Amps
Blue Sea P12 7532 - 7.5 Amps
Iota DLS-45/IQ4 - 11 Amps
1000W Engine Heater - 8.33 Amps
1500W Engine Heater - 12.5 Amps
120V Air Compressor - 4.2 Amps
120V Dometic HVAC - 15 Amps

ELECTRICAL INLET CONNECTION

The electrical inlet shall be connected to the battery conditioner.

ELECTRICAL INLET COLOR

The electrical inlet connection shall include a yellow cover.

HEADLIGHTS

The cab front shall include two (2) FireTech rectangular LED headlamps with high/low beam in the same housing and two (2) separate FireTech LED high beam only headlamps mounted in bright chrome bezels.

HEADLIGHT LOCATION

The headlights shall be located on the front fascia of the cab directly below the front warning lights.

FRONT TURN SIGNALS

The front fascia shall include two (2) Whelen model M6 4.00 inch X 6.00 inch amber LED turn signals which shall be installed in a chrome radius mount housing above and outboard of the front warning and head lamps.

SIDE TURN/MARKER LIGHTS

The sides of the cab shall include two (2) Tecniq S170 LED side marker lights which shall be provided just behind the front cab radius corners. The lights shall be amber with chrome bezels.

MARKER AND ICC LIGHTS

In accordance with FMVSS, there shall be five (5) Tecniq S170 LED cab marker lamps designating identification, center and clearance provided. These lights shall be installed on the face of the cab within full view of other vehicles from ground level. The lights shall be amber with chrome bezels.

METRO FIRE APPARATUS

HEADLIGHT AND MARKER LIGHT ACTIVATION

The headlights and marker lights shall be controlled via a virtual button on the Vista display. The headlamps shall be equipped with an LED halo parking light around the perimeter of each lamp that shall activate with marker lights "on". The headlights shall turn on in the low beam setting when the park brake is disengaged. The headlights shall turn off when the park brake is engaged. The marker and LED halo parking lights shall turn on when the ignition switch is in the "On" position. There shall be a virtual dimmer control on the Vista display to adjust the brightness of the dash lights.

INTERIOR OVERHEAD LIGHTS

The cab shall include a Whelen 60CREGCS LED dome lamp located over each door. The dome lamps shall be circular in shape and shall measure approximately 6.00 inches in diameter. The lights shall include push buttons on each lamp to activate both the clear and red portions of the light individually.

INTERIOR OVERHEAD LIGHTS ACTIVATION

The clear portion of each lamp shall be activated by opening the respective door and via the multiplex display. The virtual button shall be a multilevel switch that cycles red, clear and off.

AUXILIARY DOME LIGHT FRONT CENTER

The cab shall include a Whelen 60CREGCS LED dome lamp as an auxiliary dome light. The dome lamp shall be circular in shape and shall measure approximately 6.00 inches in diameter. The auxiliary dome light shall be located over the engine tunnel. The light shall include push buttons to activate both the clear and red portions of the light individually.

AUXILIARY DOME LIGHT FRONT CENTER ACTIVATION

The auxiliary dome light shall have the same activation as the interior overhead lights.

LIGHTBAR PROVISION

There shall be one (1) light bar installed on the cab roof. The light bar shall be provided and installed by the chassis manufacturer. The light bar installation shall include a lowered mounting that shall place the light bar just above the junction box and wiring to a control switch on the cab dash.

CAB FRONT LIGHTBAR MODEL

The cab shall be provided with one (1) Whelen model F4N72 light bar. The light bar shall be 72.00 inches in length and feature eighteen (18) customizable pods.

See the light bar layout for specific details.

LIGHTBAR SWITCH

The light bar shall be controlled by a virtual button on the vehicle display and control screen. This button shall be clearly labeled for identification.

FRONT SCENE LIGHTS

The front of the cab shall include two (2) Whelen Pioneer model PCH2 contour roof mount scene lights installed on the brow of the cab.

METRO FIRE APPARATUS

Each 150 watt lamp head shall incorporate a 12 volt DC Super-LED combination flood/spot light installed in a die-cast aluminum housing. Each lamp head shall use a collimator/metalized redux spot/flood reflector assembly with Proclera™ silicone optics and a clear non-optic polycarbonate lens. The lens/reflector assembly shall utilize a liquid injected molded silicone gasket to be resistant to water, moisture, dust, and other environmental conditions. The PCH2 shall be vibration resistant. The Pioneer PC boards shall be conformal coated for additional protection. Each combination flood/spot light lamp head shall draw 13.0 amps in spotlight mode and generate 17,750 lumens total. Each lamp head shall measure 4.25 inches in height X 14.00 inches in width. The lamp heads and brackets shall be powder coated white.

FRONT SCENE LIGHT LOCATION

There shall be two (2) scene lights mounted to the front brow of the cab in the outboard position.

FRONT SCENE LIGHTS ACTIVATION

The front scene lighting shall be activated by a virtual button on the vehicle display and control screen and a lighted momentary rocker switch on the dash.

SIDE SCENE LIGHTS

The cab shall include two (2) Whelen model Pioneer PCH2 semi-recess mount lights installed one (1) on each side of the cab.

Each 150 watt lamp head shall incorporate a 12 volt DC Super-LED combination flood/spot light installed in a die-cast aluminum housing. Each lamp head shall use a collimator/metalized redux spot/flood reflector assembly with Proclera™ silicone optics and a clear non-optic polycarbonate lens. The lens/reflector assembly shall utilize a liquid injected molded silicone gasket to be resistant to water, moisture, dust, and other environmental conditions. The PCH2 shall be vibration resistant. The Pioneer PC boards shall be conformal coated for additional protection. Each combination flood light lamp head shall draw 13.0 amps in spotlight mode and generate 17,750 lumens total. Each lamp head shall measure 4.25 inches in height X 14.00 inches in width. Each lamp head shall be mounted within a semi-recess housing featuring a chrome flange which shall measure 7.92 inches in height X 17.17 inches in width. The lamp heads and brackets shall be powder coated white.

SIDE SCENE LIGHT LOCATION

The scene lighting located on the left and right sides of the cab shall be mounted rearward of the cab "B" pillar in the 10.00 inch raised roof portion of the cab between the front and rear crew doors.

SIDE SCENE ACTIVATION

The scene lights shall be activated by two (2) lighted momentary rocker switches located in the switch panel, one (1) for each light, by two (2) virtual buttons on the vehicle display and control screen(s), one (1) for each light, and by opening the respective side cab doors.

REAR SCENE LIGHTS

The vehicle shall include multiplex activated rear scene lighting for body builder installed scene lights and body builder installed multiplex output.

REAR SCENE LIGHT ACTIVATION

The rear scene lighting shall be activated via a virtual button on the Vista display and control screen.

METRO FIRE APPARATUS

GROUND LIGHTS

Each door shall include a Tecniq T44 LED ground light mounted to the underside of the cab step below each door. The lights shall include a polycarbonate lens, a housing which is vibration welded and LEDs which shall be shock mounted for extended life.

GROUND LIGHTS

The ground lighting shall be activated when the parking brake is set, by the opening of the door on the respective cab side, through a virtual button on the vehicle display and control screen, when the truck is placed into reverse, and by the respective side turn signal.

UNDER BUMPER LIGHTS

There shall be two (2) 4.00 inch round LED NFPA compliant ground lights mounted under the bumper. The lights shall include a polycarbonate lens, a housing which is vibration welded, and LEDs which shall be shock mounted for extended life. The under bumper ground lighting shall activate with the ground lights.

LOWER CAB STEP LIGHTS

The middle step located at each door shall include a Tecniq T44 LED light which shall activate with the opening of the respective door. The lights shall include a polycarbonate lens, a housing which is vibration welded and LEDs which shall be shock mounted for extended life.

INTERMEDIATE STEP LIGHTS

The intermediate step well area at each door shall include a TecNiQ D06 LED light within a chrome housing. The egress step lights shall provide visibility to the step well area for the first step exiting the vehicle. The egress step lights shall activate with entry step lighting.

ENGINE COMPARTMENT LIGHT

There shall be a LED NFPA compliant light mounted under the engine tunnel for area work lighting on the engine. The light shall activate automatically when the cab is tilted.

DO NOT MOVE APPARATUS LIGHT

The front headliner of the cab shall include a flashing red TecNiQ K50 LED light clearly labeled "Do Not Move Apparatus". In addition to the flashing red light, an audible alarm shall be included which shall sound while the light is activated.

The flashing red light shall be located centered left to right for greatest visibility.

The light and alarm shall be interlocked for activation when either a cab door is not firmly closed, or an apparatus compartment door is not closed, and the parking brake is released.

MASTER WARNING SWITCH

A master switch shall be included, as a virtual button on the vehicle display and control screen which shall be labeled "E Master" for identification. The button shall feature control over all devices wired through it. Any warning device switches left in the "ON" position when the master switch is activated shall automatically power up.

There shall be an additional virtual button on the vehicle display and control screen to manually override an automatic warning light dimmer clearly labeled "WARNING LIGHT DIMMER". The warning light dimmer will automatically reduce the brightness of the warning lights with the display screen "Night" dimmer setting and with the park brake set. The

METRO FIRE APPARATUS

operator can override the warning light dimmer feature and manually select the warning lights to be at normal brightness using the warning light dimmer virtual button, or "Day" display screen brightness. The lights shall also default to normal brightness when the "E Master" button is activated, and the park brake is released.

HEADLIGHT FLASHER

An alternating high beam headlight flashing system shall be installed into the high beam headlight circuit which shall allow the high beams to flash alternately from left to right.

Deliberate operator selection of high beams will override the flashing function until low beams are again selected. Per NFPA, these clear flashing lights will also be disabled "On Scene" when the park brake is applied.

HEADLIGHT FLASHER SWITCH

The flashing headlights shall be activated through a virtual button on the Vista display and control screen. There shall be no blocking mode on clear warning lights.

INBOARD FRONT WARNING LIGHTS

The cab front fascia shall include two (2) Whelen M6 Super LED front warning lights in the left and right inboard positions. The lights shall feature multiple flash patterns including steady burn. The lights shall be mounted to the front fascia of the cab within a chrome bezel. The warning lights shall be set to emit the "TripleFlash 75" in/out flash pattern.

INBOARD FRONT WARNING LIGHTS COLOR

The warning lights mounted on the cab front fascia in the inboard positions shall be blue with a clear lens.

OUTBOARD FRONT WARNING LIGHTS

The cab front fascia shall include two (2) Whelen M6 Super LED front warning lights in the left and right outboard positions. The lights shall feature multiple flash patterns including steady burn. The lights shall be mounted to the front fascia of the cab within a chrome bezel. The warning lights shall be set to emit the "TripleFlash 75" in/out flash pattern.

OUTBOARD FRONT WARNING LIGHTS COLOR

The warning lights mounted on the cab front fascia in the outboard position shall be red with a clear lens.

BUMPER FACE WARNING LIGHT

The front bumper face shall include two (2) Whelen M6 series 4.31 inch tall X 6.75 inch wide Super LED® warning lights located between the frame rails in the right and left side outboard positions. The warning lights shall feature multiple flash patterns including steady burn. The lights shall be surface mounted within a chrome bezel. The warning lights shall be set to flash "TripleFlash 75" in/out flash pattern.

BUMPER FACE WARNING LIGHT COLOR

The warning lights in the bumper shall be red with clear lenses.

FRONT WARNING SWITCH

The front warning lights shall be controlled through a virtual control on the vehicle display and control screen. This switch shall be clearly labeled for identification.

METRO FIRE APPARATUS

INTERSECTION WARNING LIGHTS

The chassis shall include two (2) Whelen M6 series Super LED intersection warning lights, one (1) each side. The lights shall feature multiple flash patterns including steady burn. The lights shall be set to flash "TripleFlash 75" I/O flash pattern.

INTERSECTION WARNING LIGHTS COLOR

The intersection lights shall be red with a clear lens.

INTERSECTION WARNING LIGHTS LOCATION

The intersection lights shall be mounted centered front to rear on the flat portion of the side of the bumper tail.

SIDE WARNING LIGHTS

The cab sides shall include two (2) Whelen M6 Super LED warning lights, one (1) on each side. The lights shall feature multiple flash patterns including steady burn for solid colors and multiple flash patterns for split colors. The lights shall be mounted to the sides of the cab within a chrome bezel. The light shall be programmed to emit the "TripleFlash 75" in/out flash pattern.

SIDE WARNING LIGHTS COLOR

The warning lights located on the side of the cab shall be red with clear lens.

SIDE WARNING LIGHTS LOCATION

The warning lights on the side of the cab shall be mounted over the front wheel well directly over the center of the front axle.

AUXILIARY SIDE WARNING LIGHTS

The cab sides shall include two (2) Whelen series M6 Super LED 4.00 inch X 6.00 inch warning lights, one (1) each side, which shall feature multiple flash patterns including steady burn. The warning lights shall be set to flash "TripleFlash 75" in/out flash pattern.

AUXILIARY SIDE WARNING LIGHTS COLOR

The auxiliary warning lights located on the side of the cab shall be red with clear lens.

AUXILIARY SIDE WARNING LIGHTS LOCATION

The auxiliary warning lights on the side of the cab shall be mounted above the front doors.

SIDE AND INTERSECTION WARNING SWITCH

The side warning lights shall be controlled through a virtual button on the vehicle display and control screen. This button shall be clearly labeled for identification.

TANK LEVEL LIGHTS

There shall be two (2) FRC MaxVision surface mount water level light strips.

METRO FIRE APPARATUS

The light strips shall feature four (4) colors of LED lights to indicate the fluid level of a tank. The colors from top to bottom shall be green, blue, amber, and red.

TANK LEVEL LIGHTS ACTIVATION

The tank level lights shall be pre-wired and coiled at rear of the cab for connection to the apparatus by the body builder.

TANK LEVEL LIGHTS LOCATION

There shall be water level lights mounted on each side of the cab, centered between the rear cab doors and the rear corners of the cab.

REAR WARNING LIGHTS

The cab shall have a Whelen TACTL5 Traffic Advisor control head installed and wired in the header above the driver. The control head shall be mounted in the driver's side header inboard of the radio position.

The power to the control head shall be ignition switched and activation dependent upon the state of the controllers switched position upon ignition.

Wiring provisions shall be provided routed to the rear of the frame for OEM installation of up to eight (8) individual traffic advisor warning lights rated at no more than one (1) amp each.

INTERIOR DOOR OPEN WARNING LIGHTS

The interior of each door shall include one (1) 15.87 inch long X 0.73 inch tall amber Weldon LED warning light. The light shall be located on the upper portion of the door frame to be visible when a person is standing in front of the door while entering or exiting the cab. Each light shall activate with a scrolling directional flash pattern which moves from inside to outside when the door is in the open position. This shall serve as a warning to oncoming traffic.

SIREN CONTROL HEAD

A Whelen 295HFSC9 electronic siren control head shall be provided. The siren head shall feature a 200-watt output, wail, yelp, manual siren, and hands free operation which shall allow the operator to turn the siren on and off from the horn ring if a horn/siren selector switch option is also selected. The siren shall be installed in the switch panel with a location specific to the customer's needs.

STEERING WHEEL HORN BUTTON SELECTOR SWITCH

A virtual button on the Vista display and control screen shall be provided to allow control of the electric horn or the air horn from the steering wheel horn button. The horn button selection shall default to the air horn each time the Vista screen power is cycled off and on.

AUDIBLE WARNING LH FOOT SWITCH

A foot switch wired to actuate the mechanical siren(s) shall be supplied for installation in the front section of the cab for driver actuation.

MECHANICAL SIREN FOOT SWITCH LH

The mechanical siren foot switch shall be a Linemaster model 491-S.

METRO FIRE APPARATUS

MECHANICAL SIREN FOOT SWITCH LH LOCATION

The mechanical siren foot switch shall be located on the left hand side accessible to the driver between the steering column and the door.

MECHANICAL SIREN FOOT SWITCH LH POSITION

The mechanical siren foot switch shall be positioned outboard of any other foot switch, if applicable.

AUDIBLE WARNING LH FOOT SWITCH BRACKET

A 30.00 degree angled foot switch bracket, wide enough to accommodate (2) foot switches, shall be installed outboard of the steering column for specified driver accessible foot switch activations.

AIR HORN AUXILIARY ACTIVATION

The air horn activation shall be accomplished by a momentary rocker switch on the switch panel.

MECHANICAL SIREN BRAKE/AUXILIARY ACTIVATION

The mechanical siren shall be actuated by a momentary rocker switch in the switch panel on the dash. A red momentary siren brake rocker switch shall be provided in the switch panel on the dash. A virtual button for the siren brake shall be provided on the vehicle display and control screen.

MECHANICAL SIREN INTERLOCK

The siren activation shall be interlocked with the park brake and shall only be active when master warning switch is on to prevent accidental engagement.

BACK-UP ALARM

An ECCO model 575 backup alarm shall be installed at the rear of the chassis with an output level of 107 dB. The alarm shall automatically activate when the transmission is placed in reverse.

INSTRUMENTATION

An ergonomically designed instrument panel shall be provided. Each gauge shall be backlit with LED lamps. Stepper motor movements shall drive all gauges. The instrumentation system shall be multiplexed and shall receive ABS, engine, and transmission information over the J1939 data bus to reduce redundant sensors and wiring.

A twenty eight (28) icon lightbar message center with integral LCD odometer/trip odometer shall be included. The odometer shall display up to 999,999.9 miles. The trip odometer shall display 9,999.9 miles. The LCD message center screen shall be capable of custom configuration by the users for displaying certain vehicle status and diagnostic functions.

The instrument panel shall contain the following gauges:

One (1) three-movement gauge displaying vehicle speed, fuel level, and Diesel Exhaust Fluid (DEF) level. The primary scale on the speedometer shall read from 0 to 100 MPH, and the secondary scale on the speedometer shall read from 0 to 160 KM/H. The scale on the fuel and DEF level gauges shall read from empty to full as a fraction of full tank capacity. Red indicator lights in the gauge and an audible alarm shall indicate low fuel or low DEF at 1/8th tank level.

One (1) three-movement gauge displaying engine RPM, and primary and secondary air system pressures shall be included. The scale on the tachometer shall read from 0 to 3000 RPM. The scale on the air pressure gauges shall read

METRO FIRE APPARATUS

from 0 to 150 pounds per square inch (PSI) with a red line zone indicating critical levels of air pressure. Red indicator lights in the gauge and an audible alarm shall indicate low air pressure.

One (1) four-movement gauge displaying engine oil pressure, coolant temperature, voltmeter, and transmission temperature shall be included. The scale on the engine oil pressure gauge shall read from 0 to 100 pounds PSI with a red line zone indicating critical levels of oil pressure. A red indicator light in the gauge and audible alarm shall indicate low engine oil pressure. The scale on the coolant temperature gauge shall read from 100 to 250 degrees Fahrenheit (°F) with a red line zone indicating critical coolant temperatures. A red indicator light in the gauge and audible alarm shall indicate high coolant temperature. The scale on the voltmeter shall read from 9 to 18 volts with a red line zone indicating critical levels of battery voltage. A red indicator light in the gauge and an audible alarm shall indicate high or low system voltage. The low voltage alarm shall indicate when the system voltage has dropped below 11.8 volts for more than 120 seconds in accordance with the requirements of NFPA 1901. The scale on the transmission temperature gauge shall read from 100 to 300 degrees °F with a red line zone indicating critical temperatures. A red indicator light in the gauge and an audible alarm shall indicate a high transmission temperature.

The light bar portion of the message center shall include twenty-eight (28) LED backlit indicators. The lightbar shall be split with fourteen (14) indicators on each side of the LCD message screen. The lightbar shall contain the following indicators and produce the following audible alarms when supplied in conjunction with applicable configurations:

RED INDICATORS

- Stop Engine - indicates critical engine fault
- Air Filter Restricted - indicates excessive engine air intake restriction
- Park Brake - indicates parking brake is set
- Low Coolant - indicates critically low engine coolant
- Cab Tilt Lock - indicates the cab tilt system locks are not engaged.

AMBER INDICATORS

- Malfunction Lamp (MIL) - indicates an engine emission control system fault
- Check Engine - indicates engine fault
- Check Transmission - indicates transmission fault
- Anti-Lock Brake System (ABS) - indicates anti-lock brake system fault
- High exhaust system temperature – indicates elevated exhaust temperatures
- Water in Fuel - indicates presence of water in fuel filter
- Wait to Start - indicates active engine air preheat cycle
- Windshield Washer Fluid – indicates washer fluid is low
- DPF restriction - indicates a restriction of the diesel particulate filter
- Regen Inhibit-indicates regeneration of the DPF has been inhibited by the operator
- Range Inhibit - indicates a transmission operation is prevented and requested shift request may not occur.
- SRS - indicates a problem in the supplemental restraint system
- Check Message - indicates a vehicle status or diagnostic message on the LCD display requiring attention.

GREEN INDICATORS

- Left and Right turn signal indicators
- ATC - indicates low wheel traction for automatic traction control equipped vehicles, also indicates mud/snow mode is active for ATC system
- High Idle - indicates engine high idle is active.
- Cruise Control - indicates cruise control is enabled
- OK to Pump - indicates the pump is engaged and conditions have been met for pump operations
- Pump Engaged - indicates the pump transmission is currently in pump gear
- Auxiliary Brake - indicates secondary braking device is active

BLUE INDICATORS

- High Beam indicator

METRO FIRE APPARATUS

AUDIBLE ALARMS

Air Filter Restriction
Cab Tilt Lock
Check Engine
Check Transmission
Open Door/Compartment
High Coolant Temperature
High or Low System Voltage
High Transmission Temperature
Low Air Pressure
Low Coolant Level
Low DEF Level
Low Engine Oil Pressure
Low Fuel
Stop Engine
Water in Fuel
Extended Left/Right Turn Signal On
ABS System Fault

BACKLIGHTING COLOR

The instrumentation gauges and the switch panel legends shall be backlit using white LED backlighting.

RADIO

A Jensen brand radio with weather band, AM/FM stereo receiver, rear RCA input pigtail connector, Bluetooth, satellite radio capability, and a covered front auxiliary mini stereo input with iPod ready front and rear USB inputs shall be installed in a customer specified location.

RADIO AUXILIARY INPUT

There shall be an auxiliary audio port with USB interface and 1/8" stereo input jack for use with smart phone or a portable electronic device. The auxiliary port shall be located within the center dash switch panels in a location chosen by the customer.

RADIO LOCATION

The radio shall be installed in the left hand overhead position above the driver.

AM/FM ANTENNA

A small antenna shall be located on the left hand side of the cab roof for AM/FM and weather band reception.

RADIO SPEAKERS

There shall be two (2) speakers installed in the front portion of the cab recessed overhead and two (2) speakers installed in the rear portion of the cab overhead. The speakers shall be provided for connection to the sound system.

CAMERA RIGHT HAND

One (1) Audiovox Voyager heavy duty rearview teardrop shaped chrome plated housing camera shall be mounted on the officer side of the cab below the windshield ahead of the front door at approximately the same level as the cab door handles. The camera display shall activate when the right side turn signal is activated.

METRO FIRE APPARATUS

CAMERA REAR

One (1) Audiovox Voyager heavy duty box shaped HD camera shall be shipped loose for OEM installation in the body to afford the driver a clear view to the rear of the vehicle.

The rear camera display shall activate when the vehicle's transmission is placed in reverse.

CAMERA DISPLAY

The camera system shall be wired to a single vehicle display and control screen located on the driver's side dash. The camera system display can be activated through the vehicle display and control screen.

CAB EXTERIOR PROTECTION

The cab face shall have a removable plastic film installed over the painted surfaces to protect the paint finish during transport to the body manufacturer.

FIRE EXTINGUISHER

A 2.50 pound D.O.T approved fire extinguisher with BC rating shall be shipped loose with the cab.

DOOR KEYS

The cab and chassis shall include a total of four (4) door keys for the manual door locks.

WARRANTY

Purchaser shall receive a Custom Chassis Two (2) Years or 36,000 Miles limited warranty in accordance with, and subject to, warranty certificate RFW0102. The warranty certificate is incorporated by reference into this proposal, and included with this proposal or available upon request.

CHASSIS OPERATION MANUAL

The chassis operation manual shall be contained in an on board USB digital storage device. The chassis operation manual shall be accessible through a USB port provided in the OBD diagnostic panel.

ENGINE AND TRANSMISSION OPERATION MANUALS

The following manuals specific to the engine and transmission models ordered will be included with the chassis in the ship loose items:

- (1) Hard copy of the Engine Operation and Maintenance manual with digital copy
- (1) Digital copy of the Transmission Operator's manual
- (1) Digital copy of the Engine Owner's manual

CAB/CHASSIS AS BUILT WIRING DIAGRAMS

The cab and chassis wiring schematics and option wiring diagrams shall be contained in an on board USB digital storage device. The cab and chassis wiring schematics and option wiring diagrams shall be accessible through a USB port provided in the OBD diagnostic panel.

METRO FIRE APPARATUS

PAINT CONFIRMATION

There shall be a paint confirmation letter sent to the body manufacturer with paint spray outs to confirm the cab primary paint color or primary and secondary paint color as specified by the paint options.

SALES TERMS

The sale of the chassis shall be governed by the terms contained on the Sales Terms – Acceptance of Purchase Order document, a copy of which is attached to this option.

CHASSIS REQUIRED LABELING

Signs that state "Occupants must be seated and belted when apparatus is in motion" shall be provided.

They shall be visible from each seating position.

There shall be a lubrication plate mounted inside the cab listing the type and grade of lubrication used in the following areas on the apparatus and chassis:

- Engine oil
- Engine Coolant
- Transmission Fluid
- Pump Transmission Lubrication Fluid
- Drive Axle Lubrication Fluid
- Generator Lubrication Fluid (where applicable)
- Tire Pressures

APPARATUS INFORMATION LABEL

There shall be a high-visibility label installed in a location clearly detectable to the driver while in the seated position.

The label shall indicate the following specified information.

- Overall Height (feet and inches)
- Overall Length (feet and inches)
- Overall GVWR (tons or metric tons)

HELMET RESTRAINTS

All NFPA required helmet restraints will be supplied and installed by the Fire Department prior to the truck being placed into service.

MUD FLAPS

Heavy-duty rubber mud flaps shall be installed behind the rear wheels. The mud flaps shall be black rubber type and be bolted in place.

CAB TILT PENDANT CONTROL

There shall be a cab tilt pendant control provided and installed on the right side of the apparatus. The pendant shall be located directly behind the upper removable pump access panel, accessible through a small hinged door secured with a push button style latch. A label shall be provided that states "CAB TILT". The cab tilt door shall open towards the rear of body.

METRO FIRE APPARATUS

There shall also be a cab tilt instruction plate located as close as possible to the control pendant for ease of operation.

AIR TANK DRAIN LINES (extended)

There shall be manual pull air tank drain lines provided with the apparatus. The air drain lines shall be extended to the outer edge of the apparatus to facilitate draining moisture from the chassis air tanks to a single location for all drains and shall be actuated by a key ring. A label shall be affixed indicating "Air Tank Drain".

HEAT EXCHANGER

A supplementary heat exchanger cooling system shall be provided with the chassis and shall be complete to the discharge side of the fire pump through the engine compartment, without intermixing, for absorption of excess heat. The heat exchanger shall be adequate in size to maintain the temperature of the coolant in the pump drive engine not in excess of the engine manufacturer's temperature rating under all pumping conditions.

Appropriate drains shall be provided to allow draining the heat exchanger to prevent damage from freezing. A manual shut-off valve shall be supplied at the pump operator's position.

FUEL FILL DOOR

There shall be an aluminum fuel fill assembly located on the apparatus body accessing the chassis supplied fuel tank. The assemblies shall be located in the upper area of the rear wheel on the left and right side.

The fuel fill assembly will have a brushed aluminum door. There shall be a drain in the fuel fill assembly to allow over flow to drain on the back side of the apparatus body. The fuel fill cap shall be removable, manufactured of plastic materials, green in color and equipped with a tether.

The fuel fill cap shall be labeled "DIESEL FUEL". The stainless steel fuel fill neck shall have a 3/8" inside diameter vent line installed from the top of the fuel tank to the fill tube.

TOP MOUNT PUMP CONTROL MODULE

The top mount pump operator's control module shall be a console style operated control panel with the operator facing the rear of the apparatus while using the controls. Access to the top mount control panel shall be provided from either side of the apparatus through a walkway support structure. The operator control area shall span the entire width of the pump control module.

The top mount pump control module shall be a self-supported structure mounted independently from the body and chassis cab. The pump module frame shall be constructed entirely of 6061-T6 aluminum extrusions and 5052-H32 aluminum plate.

The pump module design shall allow normal frame deflection through isolation mounts without imposing stress on the pump module structure, walkway area, or side running boards. The pump module support shall bolt directly to the chassis frame web.

VIBRA-TORQUE™ PUMP MODULE MOUNTING SYSTEM

The entire pump module assembly shall be mounted so that it "floats" above the chassis frame rails exclusively with Vibra-Torq™ torsion isolator assemblies to reduce the vibration and stress providing an extremely durable pump module mounting system.

The pump module substructure shall be mounted above the frame to allow independent flexing to occur between the body and the chassis. Each assembly shall be mounted to the chassis frame rails with steel, gusseted mounting brackets. Each bracket shall be powder coated for corrosion resistance. Each pump compartment mount bracket shall

METRO FIRE APPARATUS

be mounted to the side chassis frame flange with two 5/8"-UNC Grade 5 HHCS.

Each assembly shall have a two-part rubber vibration isolator. The isolator shall be of a specific durometer to carry the necessary loads of the pump module, apparatus body, equipment, tank, water, and hose. The quantity of mounts utilized shall correspond directly to the anticipated weight being supported. Certain assemblies shall also incorporate a torsion spring. Helical coil springs shall be incorporated into specific mounts in tandem with the rubber isolators to minimize the stress absorbed by the body caused from chassis frame rail flexing.

There shall be no welding to the chassis frame rail sides, web or flanges, or drilling of holes in the top or bottom frame flanges between axles. All pump module to chassis connections shall be bolted so that in the event of an accident, the body shall be easily removable from the truck chassis for repair or replacement.

Because of the constant vibration and twisting action that occurs in chassis frame rails and suspension, the torsion mounting system is required to minimize the possibility of premature pump module structural failures. The Vibra-Torque™ mounting system shall have a lifetime warranty.

PUMP COMPARTMENT WORK LIGHT

One (1) 24.00 inch (61.00 cm) OnScene Solutions "Access" series tube light shall be installed inside the pump compartment module to illuminate the plumbing and piping components.

The work light shall activate with the same rocker switch as the pump panel lights.

PUMP MODULE PANELS

The panels shall be an integral part of the pump module structure. The driver's and officer's side panels shall consist of a fixed upper diamond plate panel, and two (2) removable panels, one (1) lower and one (1) upper. The removable panels shall provide ease of access for service and maintenance. The upper removable panel shall use push button latches while the lower removable panel shall be attached to the module frame utilizing mechanical fasteners.

OPERATOR'S GAUGE PANEL

The top operator's gauge panel shall include an integrated formed light shield at the top edge. The gauge panel shall span the entire width of the pump control module. The panel shall be designed to pivot forward and allow access to the backside of the components installed in the panel. Cable hold-open straps shall be mounted on the gauge panel and module structure to prevent the panel from being completely detached from the pump module.

PUMP PANEL & OPERATOR'S PANEL FINISH

The pump module panels and the operator's panel shall be brushed stainless steel finish.

LEFT SOFT SUCTION HOSE STORAGE

There shall be a recessed cavity on the left side of the pump compartment module integrated into the side panel. The cavity shall be located rearward of the steamer inlet and be capable of storing a 25 foot roll of 5.00 inch suction hose. The cavity shall be approximately 12 inches (304.8 mm) wide x 17.5 inches (444.5 mm) high x 12.5 inches (317.5 mm) deep. The floor area shall have a light taper downward to assist in restraining the hose. Drain holes shall be provided in the rear corners.

SEATBELT HOLD DOWN STRAP

There shall be one (1) aircraft style seat belt type hose hold down installed on each storage area. The hold down will be used to secure the stored hose in place during transit.

METRO FIRE APPARATUS

STORAGE CAVITY INTERIOR FINISH

The interior of the storage compartments shall feature a painted medium gray speedliner finish.

TOP MOUNT PUMP PANEL LIGHTING

Illumination shall be provided for viewing controls, switches, gauges and instructional labels necessary for proper operation of the apparatus and equipment installed.

The top operator's control panel shall be illuminated by two (2) 24.00 inch (61.00 cm) OnScene "Access" lights mounted outboard, and one (1) 10.00 inch (24.50 cm) OnScene "Access" LED tube light center mounted within the control panel's integrated light shield.

The side pump panels shall be illuminated by OnScene "Access" LED tube lights installed within gusseted reinforced embossed aluminum diamond plate steps. One (1) mounted on the driver's side and one (1) on the officer's side directly above the main pump access panels. The steps shall serve as light shields being a minimum of 8" deep and have a handrail incorporated into the step. The steps shall be mounted with 3/8" bolts. One (1) mounted on the driver's side and one (1) on the officer's side directly above the main pump access panels.

PUMP PANEL SWITCHING

Two (2) lights on the top operator's pump panel shall be controlled by a rocker switch while the third center light shall illuminate when the pump is engaged and it is "OK TO PUMP".

The side panel lights shall activate when the park brake is engaged.

WALKWAY

An embossed aluminum diamond plate walkway shall be provided at the front of the top operator's module and shall be approximately 20.00 inches wide.

The walkway shall be integral to the pump compartment module.

WALKWAY STEPS

Two (2) steps shall be installed between the running board and operator walkway surface, one (1) each side.

Each surface of the step shall be manufactured of a fixed formed embossed aluminum diamond plate and be capable of sustaining a 500 pound static load.

WALKWAY LIGHTING

Two (2) OnScene 9.00 inch "Access Pro" LED strip lights with an aluminum bezel shall be installed to illuminate the top mount walkway stepping areas, one (1) each side at the front of the pump compartment module.

Two (2) OnScene 9.00 inch "Access Pro" LED strip lights with an aluminum bezel shall be installed to illuminate the side stepping areas, one (1) each side under the fixed step.

The lights shall be directed towards and positioned to illuminate the stepping surfaces.

WALKWAY LIGHTING ACTIVATION

The walkway step lights shall be activated when the park brake is set.

METRO FIRE APPARATUS

HANDRAILS

Two (2) 1.25-inch (31.75 mm) diameter handrail constructed of extruded aluminum with 18.00 inches of grip surface shall be installed one (1) each side of the pump compartment module's outer tube face to assist in climbing the steps according to (NFPA) 1901, Standard for Automotive Fire Apparatus. The handrails shall use off-set stanchions angling them toward the walkway.

There shall be a 2.00 inch (50.80 mm) minimum clearance between the bracket and the body.

Two (2) 1.25-inch (31.75 mm) diameter handrails constructed of extruded aluminum shall be installed forward of the crosslay area, one (1) each side of the pump compartment module. The handrails shall be sized appropriately for the space.

VALVE CONTROL – TOP MOUNT ASSEMBLY

Unless specified otherwise, the valves shall be controlled from a top mounted locking valve actuation control assembly that shall be installed on the specified discharge and suction. The Class 1 assembly shall have a round chrome plated handle with an ergonomically designed surface to allow for a secure grip to turn and lock the handle. The assembly shall have a name plate insertion recess area. A brass bushing and stainless steel rod shall never require lubrication. The valve operating mechanism will indicate the position of the valve at all times.

RUNNING BOARDS

Running boards shall be installed on each side of the pump compartment module. The running boards shall be constructed of .188 inch (4.76 mm) embossed aluminum diamond plate. Each shall be a minimum of approximately 12.00 inches deep by the width of the module.

The running boards shall have a 1.25 inch upward bend on the inside edge to act as a kick plate.

The aluminum diamond plate shall meet recommendations for slip resistant surfaces at the time of proposal.

The running boards shall be attached to a frame mounted outrigger support structure. Each running board to have a 3.00 inch downward bend on the outboard face with a 1.50 inch underside return for superior strength.

RUNNING BOARD HOSE WELL

A floating hose well shall be installed in the running board directly below the pump house module, on the right hand side.

SEATBELT HOLD DOWN STRAP

There shall be two (2) seat belt type hose hold downs installed on each storage area. The hold downs will be used to secure the stored hose in place during transit.

APPARATUS PLUMBING LABELING

Innovative Controls verbiage tag bezels shall be installed. The bezel assemblies will be used to identify apparatus components. These tags shall be designed and manufactured to withstand the specified apparatus service environment and shall be backed by a warranty equal to that of the exterior paint and finish. The verbiage tag bezel assemblies shall include a chrome-plated panel-mount bezel with durable easy-to-read UV resistant polycarbonate inserts featuring the specified verbiage and color coding. These UV resistant polycarbonate verbiage and color inserts shall be subsurface screen printed to eliminate the possibility of wear and protect the inks from fading. Both the insert labels and bezel shall be backed with 3M permanent adhesive, which meets UL969 and NFPA standards.

METRO FIRE APPARATUS

Where it is appropriate to denote foam discharges, the notation shall be incorporated into the discharge label itself. A secondary "FOAM" label and bezel will not be accepted.

PRESSURE GOVERNOR AND MONITORING DISPLAY

Fire Research "InControl 400" Series pressure governor and monitoring display kit shall be installed. The kit shall include a control module, intake pressure sensor, discharge pressure sensor, and cables. The control module case shall be waterproof and have dimensions not to exceed 5.50 inches high by 10.50 inches wide by 2.00 inches deep. The control knob shall be 2.00 inches in diameter with no mechanical stops, have a serrated grip, and a red idle push button in the center. It shall not extend more than 1.75 inches from the front of the control module. Inputs for monitored information shall be from a J1939 data bus or independent sensors. Outputs for engine control shall be on the J1939 data bus or engine specific wiring.

The following continuous displays shall be provided:

- Pump discharge; shown with four daylight bright LED digits more than 1/2" high
- Pump Intake; shown with four daylight bright LED digits more than 1/2" high
- Pressure / RPM setting; shown on a dot matrix message display
- Pressure and RPM operating mode LEDs
- Throttle ready LED
- Engine RPM; shown with four daylight bright LED digits more than 1/2" high
- Check engine and stop engine warning LEDs
- Oil pressure; shown on a dual color (green/red) LED bar graph display
- Engine coolant temperature; shown on a dual color (green/red) LED bar graph display
- Transmission Temperature: shown on a dual color (green/red) LED bar graph display
- Battery voltage; shown on a dual color (green/red) LED bar graph display.

The dot-matrix message display shall show diagnostic and warning messages as they occur. It shall show monitored apparatus information, stored data, and program options when selected by the operator. All LED intensity shall be automatically adjusted for day and nighttime operation.

The program shall store the accumulated operating hours for the pump and engine to be displayed with the push of a button. It shall monitor inputs and support audible and visual warning alarms for the following conditions:

- High Battery Voltage
- Low Battery Voltage (Engine Off)
- Low Battery Voltage (Engine Running)
- High Transmission Temperature
- Low Engine Oil Pressure
- High Engine Coolant Temperature
- Out of Water (visual alarm only)
- No Engine Response (visual alarm only).

The program features shall be accessed via push buttons and a control knob located on the front of the control panel. There shall be a USB port located at the rear of the control module to upload future firmware enhancements.

Inputs to the control panel from the pump discharge and intake pressure sensors shall be electrical. The discharge pressure display shall show pressures from 0 to 600 psi. The intake pressure display shall show pressures from -30 in. Hg to 600 psi.

The governor shall operate in two control modes, pressure and RPM. No discharge pressure or engine RPM variation shall occur when switching between modes. A throttle ready LED shall light when the interlock signal is recognized. The governor shall start in pressure mode and set the engine RPM to idle. In pressure mode the governor shall automatically regulate the discharge pressure at the level set by the operator. In RPM mode the governor shall maintain the engine

METRO FIRE APPARATUS

RPM at the level set by the operator except in the event of a discharge pressure increase. The governor shall limit a discharge pressure increase in RPM mode to a maximum of 30 psi. Other safety features shall include recognition of no water conditions with an automatic programmed response and a push button to return the engine to idle.

PRESSURE RELIEF VALVE

A Task Force Tips model #A18XX pressure relief valve shall be provided. The valve shall have an easy to read adjustment range from 90 to 300 PSI with 90, 125, 150, 200, 250 and 300 PSI adjustment settings and an "OFF" position. Pressure adjustments shall be made utilizing a 1/4" hex key, 9/16" socket or 14mm socket.

For corrosion resistance the cast aluminum valve shall be a hardcoat anodized with a powder coat interior and exterior finish. The valve shall meet (NFPA) 1901, Standard for Automotive Fire Apparatus, requirements for pump inlet relief valves. The unit shall be covered by a five year warranty. The valve shall be preset at 125 PSI (860 kPa) suction inlet pressure. The valve shall be installed inside the pump compartment where it will be easily accessible for future adjustment. The excess water shall be plumbed to the atmosphere via the unloader pipe and shall dump on the opposite side of the pump operator.

For normal pumping operations, the relief valve shall not be capped and there shall be a placard stating "DO NOT CAP" installed.

UL TEST PORTS

One (1) set of UL testing ports with plugs shall be provided on the pump panel for testing of the vacuum and pump pressures.

WATER TANK LEVEL GAUGE

A Fire Research TankVision model WLA300-A00 tank indicator kit shall be installed on the operator's panel.

The kit shall include an electronic indicator module, a pressure sensor, and a 20' sensor cable. The indicator shall show the volume of water in the tank on nine (9) easy to see super bright LEDs. A wide view lens over the LEDs shall provide for a viewing angle of 180 degrees. The indicator case shall be waterproof, manufactured of aluminum, and have a distinctive blue label.

The program features shall be accessed from the front of the indicator module. The program shall support self-diagnostics capabilities, self-calibration, and a datalink to connect remote indicators. Low water warnings shall include flashing LEDs at 1/4 tank, down chasing LEDs when the tank is almost empty, and an output for an audio alarm.

The indicator shall receive an input signal from an electronic pressure sensor. The sensor shall be mounted from the outside of the water tank near the bottom. No probe shall place on the interior of the tank. Wiring shall be weather resistant and have automotive type plug-in connectors.

TANK LEVEL DRIVER GAUGE

Additional tank level gauges shall be installed on the cab by the chassis manufacturer. The tank level gauges shall utilize a pressure transducer and driver to provide an accurate reading of the water tank level.

AIR HORN BUTTON

The air horn shall be activated by a Carling W-series non-illuminated, momentary rocker switch with a solid red actuator provided and installed on the pump operator's panel in a rocker switch bezel.

The button shall be labeled "AIR HORN".

METRO FIRE APPARATUS

ROCKER SWITCH PANEL

All specified lighting fixtures and electrical components activated at the pump operator's panel shall be activated by Carling W-series rocker style switches.

The switches shall be located on a separate matte black Innovative Controls 6-position electrical panel, complete with backlit name tags describing the function of each individual switch.

The switches shall be laid out in the following order left to right: Panel Lights, Right Scene, Left Scene, Rear Scene, Blank Space, Air Horn.

PUMP COMPARTMENT TOP OVERLAY

The top of the pump compartment shall be overlaid with .188 inch embossed aluminum diamond plate.

MIDSHIP PUMP

The pump shall have a capacity of 1500 gallons per minute, measured in U.S. Gallons. The pump shall be a Waterous model CSU single stage midship pump.

The pumps impellers shall be bronze with double suction inlets, accurately balanced (mechanically and hydraulically), of mixed flow design with reverse-flow, labyrinth-type, wear rings that resist water bypass and loss of efficiency due to wear. The impeller shall have flame plated hub to assure maximum pump life and efficiency despite the presence of abrasive particles, such as fine sand, in the water being pumped. The wear rings shall be bronze and easily replaceable to restore original pump efficiency and eliminate the need for replacing the entire pump casing due to wear.

Pump casing shall be close grained gray iron, bronze fitted and horizontally split in two sections for easy removal of entire impeller assembly, including wear rings, without disturbing setting of pump in chassis or pump piping. The pump, for ease and rapid servicing in the future, shall have the separable impeller shaft which allows true separation of transmission or pump without disassembly or disturbing the other component. This shall be accomplished by using a two piece shaft. This feature will allow field service to accomplish in much less time since each component (pump or transmission) can be repaired independently. The impeller shaft shall be stainless steel, accurately ground to size and polished. Shaft shall be supported at each end by ball type oil grease lubricated bearings. Sleeve bearings or bushings will not be acceptable. The bearings shall be protected from water at each end of the impeller shaft.

The discharge manifold shall be cast as an integral part of the pump body assembly and shall provide at least three full 3.50 inch openings for ultimate flexibility in providing various discharge outlets for maximum efficiency and shall be located as follows: one outlet on the right side of the pump body, one outlet on the left side of the pump body, and one outlet directly on top of the pump discharge manifold.

The entire pump shall be cast, manufactured and tested at the pump manufacturer's factory. The pump transmission housing shall be high strength aluminum, three pieces and horizontally split. Power transfer to the pump shall be through a Morse Hy-Vo drive chain. Chain shall be pressure lubricated through oil pump. Chain sprockets shall be cut from carbonized, hardened alloy steel. Spur gears will not be acceptable.

The drive shafts shall be 2.35" in diameter, made of hardened and ground alloy steel. All shafts shall be ball bearing supported. Case shall be designed to eliminate the need of water cooling.

The entire pump, both suction and discharge passages, shall be hydrostatically tested to a pressure of 600 PSI. A certificate documenting this test shall be provided with the completed apparatus. The pump shall be fully tested at the pump manufacturer's factory to the performance requirements as outlined by the latest (NFPA) 1901, Standard for Automotive Fire Apparatus. Pump shall be free from objectionable pulsation and vibration.

The pump shall be the Class "A" type and shall deliver the percentage of rated discharge at pressures indicated below.

METRO FIRE APPARATUS

100% of rated capacity at 150 PSI net pump pressure.
100% of rated capacity at 165 PSI net pump pressure.
70% of rated capacity at 200 PSI net pump pressure.
50% of rated capacity at 250 PSI net pump pressure.

PUMP HOUSE WIDTH

The width of the pump house shall be 73.50 inches from front to back.

PUMP SEALS

The pump shall be equipped with maintenance free mechanical shaft seals that shall not require manual adjustment. The seal size, type, component materials, and housing configuration shall be specifically designed for the pump application and rated operating parameters as specified.

AIR PRIMER SYSTEM

The priming system shall be a Trident Emergency Products compressed air powered high efficiency, multi-stage, venturi based Air Prime System.

All wetted metallic parts of the priming system are to be of brass and stainless steel construction. A single panel mounted control will activate the priming pump and open the priming valve to the pump.

The primer shall be mounted above the pump impeller so that the priming line will automatically drain back to the pump. The primer shall also automatically drain when the panel control actuator is not in operation. The inlet side of the primer shall include a brass 'wye' type strainer with removable stainless steel fine mesh strainer to prevent entry of debris into the primer body.

The system shall employ an 80 PSI (5.5 bar) pressure protection valve, located on the chassis auxiliary air tank.

The primer shall be covered by a five (5) year parts warranty.

6.0" STEAMER INLETS

Two (2) 6.00 inch (150.00 mm) steamer inlets shall be provided, one (1) on the left side and one (1) on the right side.

Each inlet shall have a chrome plated long handle chrome vented caps and die cast zinc screens designed to provide cathodic protection for the pump. The caps shall be National Standard Thread with long handles.

PUMP COOLING LINE

There shall be a .375 inch line run from the pump to the water tank to assist in keeping the pump water from overheating. A manual class 1 1/4 turn .25 inch on/off valve with a rectangular handle shall be supplied on the operator's panel.

PUMP ANODES

Two (2) pump anodes shall be installed in plumping system of the apparatus, to prevent damage from galvanic corrosion within the pump system. There shall be one (1) anode on the intake side and one (1) on the discharge side.

MASTER PUMP DRAIN

The pump shall be equipped with a Master Pump drain to allow draining of the lower pump cavities, volute and selected water carrying lines and accessories. The drain shall have an all brass body.

METRO FIRE APPARATUS

The drain valve control shall be panel mounted and identified as MASTER DRAIN.

DRAIN VALVES

All manual drains shall be Class 1 with .75 inch J-style lift handle kit.

Each drain shall have a 90 degree push lock fitting supply with a 90 degree poly elbow drain. Reinforced clear vinyl tubing shall be utilized to route the water to atmosphere.

VALVES

All valves, unless otherwise stated, shall be of a heavy duty design capable of bi-directional flow and incorporate a self-locking ball feature and full flow optimizing characteristics that reduce the operational force required for actuation.

The valves shall be Akron 8000 series.

The valves shall be of a self-adjusting dual seat design requiring no lubrication or regular maintenance. The valve shall meet or exceed NFPA standard requirements.

PLUMBING

All plumbing and piping shall be of 304 stainless steel or flexible type piping. All inlet and outlet plumbing 3.00 inch (77 mm) and smaller shall be plumbed with either stainless steel piping or synthetic reinforced rubber hose blended with high tensile strength cord for maximum performance in tight bend applications.

Secondary plumbing such as small diameter drain lines shall be stainless steel, brass or hose. Where chassis and module flexing or vibration may damage or loosen piping or where a coupling is required for servicing, the piping shall be equipped with Victaulic or rubber type couplings.

All lines shall drain through the master drain valve or shall be equipped with individual drain valves. All individual drain lines for discharges shall be extended to the point where they shall drain below the chassis frame rails. All water carrying drain lines shall be of flexible polypropylene type tubing.

MANIFOLDS

Plumbing manifold bodies shall be ductile cast iron or stainless steel. The suction inlets shall include removable die cast zinc screens designed to provide cathodic protection for the pump, therefore reducing deterioration within the pump.

TANK FILL

One (1) 2.00 inch (50 mm) pump to tank fill line shall be installed from the discharge manifold directly to the booster tank.

TANK TO PUMP

One (1) 3.50 inch (88.9 mm) Waterous valve shall be installed between the water tank and the pump with flow recommendations as set forth by (NFPA) 1901, Standard for Automotive Fire Apparatus, and shall be tested to those standards when the pump is being certified.

TANK TO PUMP CHECK VALVE

There shall be a tank to pump check valve, conforming to NFPA standard requirements to prevent water from back flowing at an excessive rate if the pump is being supplied from a pressurized source.

METRO FIRE APPARATUS

The check valve shall be mounted as an integral part of the pump suction extension. A hole up to .25 inch (6.35 mm) is allowable in the check valve to release steam or other pressure buildup so that the void between the valve and check valve may drain of water that could be subject to freezing.

2.5" LEFT SIDE INLET

There shall be one (1) 2.50 inch (65 mm) gated suction inlet with .75 inch (19 mm) bleeder installed on the left side of the apparatus, forward of the steamer.

The inlet shall be controlled at the operator's panel.

INTAKE PLUMBING

The plumbing shall consist of 2.50 inch (65 mm) piping and shall incorporate a manual drain control installed below the pump area for ease of access.

INTAKE TERMINATION

The termination shall include the following components:

One (1) 2.50 inch (65 mm) NST swivel female straight adapter with screen

One (1) 2.50 inch (65 mm) self-venting plug, secured by a cable

2.5" LEFT SIDE DISCHARGE

There shall be one (1) 2.50 inch (65 mm) gated discharge installed on the left side of the apparatus.

2.5" SIDE DISCHARGE PLUMBING

The plumbing shall consist of 2.50 inch (65 mm) piping and shall incorporate a manual drain control installed below the pump area for ease of access.

DISCHARGE TERMINATION

The discharge termination shall include the following components:

One (1) 2.50 inch (65 mm) Male NST adapter

One (1) 2.50 inch (65 mm) NST female swivel by male with 30 degree polished elbow

One (1) 2.50 inch (65 mm) female self-venting cap, secured by a cable

2.5" RIGHT SIDE DISCHARGE

There shall be one (1) 2.50 inch (65 mm) gated discharge installed on the right side of the apparatus.

2.5" SIDE DISCHARGE PLUMBING

The plumbing shall consist of 2.50 inch (65 mm) piping and shall incorporate a manual drain control installed below the pump area for ease of access.

METRO FIRE APPARATUS

DISCHARGE TERMINATION

The discharge termination shall include the following components:

One (1) 2.50 inch (65 mm) Male NST adapter

One (1) 2.50 inch (65 mm) NST female swivel by male with 30 degree polished elbow

One (1) 2.50 inch (65 mm) female self-venting cap, secured by a cable

4.0" RIGHT SIDE DISCHARGE WITH 3.0" VALVE

There shall be one (1) gated 4.00 inch (100 mm) discharge with a 3.00 inch ball valve installed on the right side of the apparatus.

4.0" SIDE DISCHARGE PLUMBING

The plumbing shall consist of 4.00 inch (100 mm) piping and shall incorporate a manual drain control installed below the pump area for ease of access.

DISCHARGE TERMINATION

The discharge termination shall include the following components:

One (1) 4.00 inch (100 mm) NST adapter

One (1) 4.00 inch (100 mm) NST female by 5.00 inch (125 mm) Storz with 30 degree elbow

One (1) 5.00 inch (125 mm) Storz cap, secured by a cable

2.5" LEFT REAR DISCHARGE

There shall be one (1) 2.50 inch (65 mm) discharge located on the left side at the rear of the vehicle.

REAR DISCHARGE PLUMBING

The plumbing shall consist of 2.50 inch (65 mm) piping and shall incorporate a manual drain control installed below the pump area for ease of access.

DISCHARGE TERMINATION

The discharge termination shall include the following components:

One (1) 2.50 inch (65 mm) Male NST adapter

One (1) 2.50 inch (65 mm) NST female swivel by male with 30 degree polished elbow

One (1) 2.50 inch (65 mm) female self-venting cap, secured by a cable

3.0" DECK GUN DISCHARGE

There shall be a 3.00 inch (77 mm) deck gun discharge provided.

METRO FIRE APPARATUS

DECK GUN PIPING

The deluge waterway shall be plumbed with 3.00 inch (77 mm) piping that terminates in the center location at the top of the pump compartment module.

The plumbing shall be drained with an auto-drain located at the lowest point of the waterway plumbing if required.

EXTEND-A-GUN

There will be a Task Force Tips 18.00 inch (457 mm) manual Extenda-Gun, model XG18VL-PL, installed on the deluge pipe.

If the Extenda-Gun is not properly stowed and the parking brake is released, it shall activate the hazard light in the cab to alert the crew.

PUMP COMPARTMENT SPEEDLAYS

Two (2) 1.75 inch (45 mm) vertically stacked speedlays shall be installed in the front of the pump compartment module, under the top control panel.

There shall be a cutout on the front face of the pump compartment to access each speedlay hose storage area.

SPEEDLAY CAPACITY

The two (2) speedlays shall each have capacity for 200 feet of 1.75 inch (45 mm) double jacket fire hose.

DISCHARGE PLUMBING

The plumbing shall consist of 2.00 inch (50 mm) piping and shall incorporate a manual drain control installed below the pump area for ease of access.

DISCHARGE TERMINATION

The discharge termination shall include the following components:

One (1) 2.00 inch (50 mm) NPT x 1.50 inch (38 mm) NST chrome plated brass chicksan swivel

The use of a swivel shall allow hose payout to either side of the pump compartment.

FOAM CAPABLE

The following discharges shall be foam capable:

Two (2) 1.75" Speedlays
2.50 inch Crosslay
Front Bumper Discharge
Hose Reel

SPEEDLAY COVER

A fixed .188 inch aluminum diamond plate speedlay cover shall be provided at the top of the speedlay area.

The Dealership shall provide a means of restraining the hose in the speedlays on the sides of the module prior to the apparatus being placed into service.

METRO FIRE APPARATUS

CROSSLAYS

One (1) crosslay hose bed shall be located in the upper portion of the pump compartment, toward the rear. The crosslay area shall span the entire width of the pump compartment module. Slotted aluminum flooring shall be provided for the hose bed area for drainage.

CROSSLAY CAPACITY

The crosslay shall have capacity for 200 feet of 2.50 inch (65 mm) double jacket fire hose.

CROSSLAY PLUMBING

The plumbing shall consist of 2.50 inch (65 mm) piping, and shall incorporate a manual drain control installed below the pump area for ease of access.

CROSSLAY TERMINATION

The crosslay termination shall include the following components:

One (1) 2.5" NPT x 2.5" NST chrome plated brass chicksan swivel

The use of a swivel shall allow hose payout to either side of the pump compartment.

CROSSLAY COVER

The crosslay hose bed area shall have a .188 inch (4.76 mm) embossed aluminum diamond plate cover installed. The cover shall be installed to provide a solid surface over all bays. The cover shall have a hand hold slot on each end. The cover shall be attached with a full length piano style hinge.

When opened, the diamond plate cover shall rest upon rubber bumpers or an equivalent protective type stop to eliminate marring or scratching of other apparatus body work.

CROSSLAY COVER SECURED

The hinged crosslay cover shall be secured with two (2) mechanical latches.

If the crosslay cover is not properly secured and the parking brake is released, it shall activate the hazard light in the cab to alert the crew.

CROSSLAY SIDE COVERS

The crosslay hose bed area shall have a cover installed at each end of the crosslay area by the Dealership prior to the apparatus being placed into service.

CROSSLAY HOSE BED LIGHT

One (1) On Scene LED 60" Walkway series waterproof light shall be installed in an anodized aluminum housing on the front of the body to illuminate the crosslay area.

CROSSLAY LIGHT ACTIVATION

The crosslay light shall be activated with the pump "Panel Lights" switch.

METRO FIRE APPARATUS

FRONT BUMPER DISCHARGE

One (1) 1.50 inch (38 mm) front bumper discharge outlet shall be provided.

FRONT BUMPER DISCHARGE PLUMBING

The front bumper discharge plumbing shall consist of 2.00 inch (50 mm) piping and shall incorporate a manual drain control installed below the pump area for ease of access.

Auto-drain(s) shall be installed in the discharge piping at the lowest point of the plumbed system.

FRONT BUMPER DISCHARGE TERMINATION

The discharge termination shall include the following components:

One (1) 2.00 inch (50 mm) NPT x 1.50 inch (38 mm) NST polished stainless steel chicksan swivel.

The use of a swivel shall allow hose payout to either side of the apparatus.

The front bumper discharge shall be mounted on top of the gravel shield of the front bumper extension. The discharge shall be placed to the right of the hose well.

FRONT BUMPER DISCHARGE CHICKSAN GUARD

The front bumper discharge chicksan shall include a chicksan guard installed on the front bumper gravelshield to prevent the chicksan from hitting the cab. The guard shall be fabricated of smooth aluminum with a dual-action sanded finish on all sides. There shall be two (2) rubber bumper stops installed on the guard to protect the chrome chicksan.

FOAM CAPABLE

The discharge shall be foam capable.

BOOSTER HOSE REEL

There shall be one (1) Hannay electric rewind booster reel with automatic brake installed on the apparatus.

There shall be a manual rewind device provided. A manual crank shall be mounted adjacent to booster reel.

The reel shall be model number EPF28-25-26-RT, 12V, standard assembly, electric rewind right hand side, manual rewind horizontal orientation, inlet shall be 1.0" with a 90 degree swivel.

REEL FINISH

The hose reel specified shall be steel and painted the standard silver utilized by Hannay.

HOSE REEL VALVE

The reel shall be plumbed to the pump with a 1.50 inch (38.10 mm) quarter turn Akron 8815 ball valve and 1.00 inch (25.40 mm) high pressure hose and couplings.

The valve shall be controlled from the operator's panel with a push-pull control.

METRO FIRE APPARATUS

REWIND ACTIVATION

An electric rewind switch shall be mounted directly on the side wall in the B1 compartment. The switch shall have a weather resistant rubber cover and label denoting its function.

The switch shall be labeled "HOSE REEL".

The circuit breaker for the electric rewind shall be of the manual reset type and be located within easy reach of the operator.

HOSE REEL LOCATION

The hose reel shall be mounted on the floor of the B1 compartment as far to the rear and left side walls to maximize storage space on the floor of the compartment for the nozzle and other accessories.

BOOSTER REEL GAUGE

A discharge gauge shall be included for the booster reel, the discharge gauges shall be specified in the specification.

BOOSTER HOSE

The booster hose shall be provided and installed by the Dealership prior to the apparatus being placed into service.

HOSE ROLLER GUIDES

There shall be a four-way roller assembly provided and installed directly to the reel.

DISCHARGE GAUGES

An (Innovative Controls) TC 3010xxxx Series nominal 2.50 inch gauge shall be supplied for reading the pressure of each discharge greater than 1.50 inches (38 mm) in diameter, unless otherwise specified.

A KEM-X socket saver diaphragm, located in the stem, eliminates freeze-up by preventing water from entering and/or clogging the gauge internals while containing a low temperature instrument oil that fills and protects the socket and the bourdon tube.

The molded glass-filled Nylon 66 case will not corrode and includes a scratch-resistant molded polycarbonate lens with O-ring seal. The gauge shall withstand pressures up to 100psi over gauge range with operation from -40° F to +160°F.

GAUGE SCALE

Each gauge shall be marked for reading a discharge pressure of 0-400 PSI.

GAUGE FACE COLOR

Each gauge shall have black markings on a white face.

BEZELS FOR 2.5" DISCHARGE GAUGES

There shall be a Spartan bezel supplied around each of the 2.50 inch (65 mm) discharge pressure gauges.

FOAMPRO 1600

There shall be a fully automatic electronic direct injection foam proportioning system furnished and installed on the

METRO FIRE APPARATUS

apparatus. The system shall be capable of Class A foam concentrate. The proportioning operation shall be based on an accurate direct measurement of water flows with no water flow restriction. The foam system shall be installed in accordance with the manufacturer's recommendations. The foam system shall have a 12 volt, 1/3 horsepower electric positive displacement foam concentrate pump with a rated capacity of .01 to 1.7 GPM with operating pressures up to 400 psi.

The system shall be manufactured by the Fire Research Corporation and be model FoamPro 1600.

The system shall be equipped with a control module. It shall be installed on the pump operators panel and enable the pump operator to perform the following functions:

- Activate the foam system
- Change foam concentrate proportioning rates from .1% to 1%
- Flash a "low concentrate" warning light when the foam concentrate tank runs low. In two (2) minutes if foam concentrate is not added to tank, the foam concentrate pump shall be deactivated.

FOAM SYSTEM TESTING

The apparatus foam system shall be tested, and the Foam Flow meter shall be certified by the manufacturer prior to delivery.

FOAM TANK

There shall be one (1) 20 gallon foam tank with square hinged lid, equipped with a hold down device, installed and plumbed with non-corrosive piping to the foam system. The fill tower shall be approximately 8.00 inches by 8.00 inches.

A label shall be affixed to the foam tank fill indicating: "WARNING" Class A (or B) foam tank fill, do not mix brands or types of foam.

Foam tank shall be integral with the booster water tank provided

SYSTEM PLUMBED TO 1 TANK

The system shall be supplied by a single foam tank.

SHUTOFF VALVE

There shall be a 1/4 turn valve installed at the foam tank to shut off the flow from the supply line.

SINGLE 1" TANK DRAIN

There shall be a 1.00 inch quarter turn drain valve installed for drainage of the foam tank. The valve shall be installed in the pump house with a drain line extended to the side running board.

FOAM TANK LEVEL GAUGE

Fire Research TankVision Pro model WLA360-A00 tank indicator kit shall be installed. The kit shall include an electronic indicator module, a pressure sensor, a 20' sensor cable and a tank vent. The indicator shall show the volume of Class A foam concentrate in the tank on nine (9) easy to see super bright RGB LEDs. A wide view lens over the LEDs shall provide for a viewing angle of 180 degrees. The indicator case shall be waterproof, manufactured of Polycarbonate/Nylon material, and have a distinctive green label.

The program features shall be accessed from the front of the indicator module. The program shall support self-diagnostics capabilities, self-calibration, six (6) programmable colored light patterns to display tank volume, adjustable

METRO FIRE APPARATUS

brightness control levels and a datalink to connect remote indicators. Low water warnings shall include flashing LEDs at 1/4 tank, down chasing LEDs when the tank is almost empty, and an output for an audio alarm.

The indicator shall receive an input signal from an electronic pressure sensor. The sensor shall be mounted from the outside of the foam tank near the bottom. No probe shall be placed on the interior of the tank. Wiring shall be weather resistant and have automotive type plug-in connectors.

VIBRA-TORQUE™ BODY MOUNTING SYSTEM

The entire body module assembly shall be mounted to the chassis frame rails exclusively with Vibra-Torq™ torsion isolator assemblies to reduce the vibration and stress providing an extremely durable body mount.

The body substructure shall be mounted above the frame to allow independent flexing to occur between the body and the chassis. Two (2) assemblies shall be mounted to the chassis frame rails with steel, gusseted mounting brackets. Each bracket shall be painted for corrosion resistance. Each body mount bracket shall be mounted to the side chassis frame flange with two 5/8"-UNC Grade 5 HHCS.

The rear assemblies shall have a two-part rubber vibration isolator. Certain assemblies shall also incorporate a torsion spring. Helical coil springs shall be incorporated into specific mounts in tandem with the rubber isolators to minimize the stress absorbed by the body caused from chassis frame rail flexing.

There shall be no welding to the chassis frame rail sides, web or flanges, or drilling of holes in the top or bottom frame flanges between axles. All body to chassis connections shall be bolted so that in the event of an accident, the body shall be easily removable from the truck chassis for repair or replacement.

Because of the constant vibration and twisting action that occurs in chassis frame rails and suspension, the torsion mounting system is required to minimize the possibility of premature body structural failure. The Vibra-Torque™ body mounting system shall have a lifetime warranty.

COMPARTMENT VENTILATION

To allow for proper air circulation and flow, each compartment shall have a venting route. The venting locations shall be determined by "best-fit" locations for each body style configuration. The vents will be a chrome louvered and mounted appropriately on the compartment interior walls.

COMPARTMENTATION

The following compartments shall be supplied on the apparatus:

Compartment "L1"

There shall be one (1) full height compartment ahead of the rear wheels on the left side of the apparatus with interior dimensions of the following:

The upper portion shall be approximately 37.75 inches (958.85 mm) wide by 39.00 inches (990.60 mm) high by 12.50 inches (317.50 mm) deep.

The lower portion shall be approximately 37.75 inches (958.85 mm) wide by 33.00 inches (838.20 mm) high by 26.00 inches (660.40 mm) deep.

Clear door opening dimensions shall be 29.70" (754.38 mm) wide by 63.10" (1602.74 mm) high.

METRO FIRE APPARATUS

Compartment "L2"

There shall be one (1) compartment over the rear wheels on the left side of the apparatus with interior dimensions of the following:

The upper portion shall be approximately 68.00 inches (1727.20 mm) wide by 39.00 inches (990.60 mm) high by 12.50 inches (317.50 mm) deep.

The lower portion shall be approximately 68.00 inches (1727.20 mm) wide by 8.00 inches (203.20 mm) high by 25.75 inches (654.05 mm) deep.

Clear door opening dimensions shall be 65.50" (1663.70 mm) wide by 38.10" (967.74 mm) high.

Compartment "L3"

There shall be one (1) full height compartment behind the rear wheels on the left side of the apparatus with interior dimensions of the following:

The upper portion shall be approximately 46.75 inches (1187.45 mm) wide by 39.00 inches (990.60 mm) high by 12.50 inches (317.50 mm) deep.

The lower portion shall be approximately 46.75 inches (1187.45 mm) wide by 33.00 inches (838.20 mm) high by 26.00 inches (660.40 mm) deep.

Clear door opening dimensions shall be 41.70" (1059.18 mm) wide by 63.10" (1602.74 mm) high.

Compartment "R1"

There shall be one (1) full height compartment ahead of the rear wheels on the right side of the apparatus with interior dimensions of the following:

The upper portion shall be approximately 37.75 inches (958.85 mm) wide by 39.00 inches (990.60 mm) high by 12.50 inches (317.50 mm) deep.

The lower portion shall be approximately 37.75 inches (958.85 mm) wide by 33.00 inches (838.20 mm) high by 26.00 inches (660.40 mm) deep.

Clear door opening dimensions shall be 29.70" (754.38 mm) wide by 63.10" (1602.74 mm) high.

Compartment "R2"

There shall be one (1) compartment over the rear wheels on the right side of the apparatus with interior dimensions of the following:

The upper portion shall be approximately 68.00 inches (1727.20 mm) wide by 39.00 inches (990.60 mm) high by 12.50 inches (317.50 mm) deep.

The lower portion shall be approximately 68.00 inches (1727.20 mm) wide by 8.00 inches (203.20 mm) high by 25.75 inches (654.05 mm) deep.

Clear door opening dimensions shall be 65.5" (1663.70 mm) wide by 38.1" (967.74 mm) high.

METRO FIRE APPARATUS

Compartment "R3"

There shall be one (1) full height compartment behind the rear wheels on the right side of the apparatus with interior dimensions of the following:

The upper portion shall be approximately 46.75 inches (1187.45 mm) wide by 39.00 inches (990.60 mm) high by 12.50 inches (317.50 mm) deep.

The lower portion shall be approximately 46.75 inches (1187.45 mm) wide by 33.00 inches (838.20 mm) high by 26.00 inches (660.40 mm) deep.

Clear door opening dimensions shall be 41.70" (1059.18 mm) wide by 63.10" (1602.74 mm) high.

FORMED BODY DESIGN CONSTRUCTION

The apparatus body shall be a formed sheet metal design, which serves as the compartment enclosures and supporting substructure of the body. The substructure and enclosures shall work in unison to provide maximum storage that supports and protect the contents contained within.

BODY CONSTRUCTION

The body substructure and compartments shall utilize a combination of huck bolting and welding methods.

The huck bolt systems utilized in either body or substructure shall be .3125 inch (7.94 mm) or .375 inch (9.53 mm) diameter stainless steel fasteners for maximum shear and tension strength. Other system of fasteners that do not consist of stainless steel shall NOT be acceptable.

In combination with the huck bolt system, strictly monitored welding procedures shall be instituted. To ensure maximum joint strength, any welding zones shall be welded together utilizing American Welding Standard (AWS), Certified welding procedures.

Due to the engineered combination of specifically chosen materials, no dissimilar metals shall be used in the body and its supporting substructure without being separated by a sufficient corrosion and electrolysis inhibitor. This shall consist of isolation pads and structural adhesives.

ECK® ANTI-CORROSION PROCESS

Absolutely no dissimilar metals shall be used in the body and its supporting substructure without being separated by Eck®, which prevents corrosion by providing a barrier between dissimilar metals, sealing out moisture and absorbing energy created by a dissimilar metal reaction.

BODY STRUCTURE

The supporting tank and compartment substructure shall be manufactured from corrosion resistant 304L stainless steel material. The supporting material shall be engineered from 7 gauge stainless steel material to provide both high strength and corrosion resistance for longevity of the apparatus body. The use of black carbon steel materials that have been painted or coated to try to prevent corrosion shall not be acceptable.

BODY COMPARTMENTS

The formed sheet metal compartments shall utilize a 0.125 inch (3.18 mm) thick 5052-H32 aluminum alloy to provide maximum strength and durability. Each compartment sheet and enclosure shall be fabricated in a manor to provide proper sheet alignment and weld location application. The body shall consist of multiple pre-engineered compartment

METRO FIRE APPARATUS

assemblies that shall be combined to create a series of body combinations. In the event of body damage, these assemblies shall allow for easier disassembly and assembly through the use of common tools and materials.

COMPARTMENT TOPS AND EXTERIOR HOSE BED WALL

The exterior compartment tops and outer hose bed walls shall consist of .125 inch (3.18 mm) embossed aluminum diamond plate material to provide both strength and pleasing appearance. The hose bed walls shall be embossed aluminum diamond plate to the outward face while incorporating an additional smooth aluminum interior wall sheet to form the hose bed area. The use of interior and exterior hose bed wall sheets shall provide an enclosed section for strength integrity, wire routing, etc. Single hose bed wall sheet construction shall NOT be acceptable.

COMPARTMENT FLOORS

The body compartments shall be enclosed with aluminum sheet metal as specified above. The compartment floors shall have a 1.00 inch (25.40 mm) lip downward at the door opening side of the compartment. This lip shall integrate with a structural member on the bottom edge and form a "sweep-out" compartment. This design shall also allow for a structural flush fitting door frame and a complete door/weather seal.

COMPARTMENT LOAD CAPACITY

Each compartment shall have a minimum of one additional structural compartment floor support hat section centered on the underside of the compartment floor. This additional member shall be integral with compartment assemblies of each area. Each compartment must be designed, and analyzed to carry a working load of:

Full depth side compartment: 500 pounds (226.80 kg) per compartment
Half depth side compartment: 375 pounds (170.10 kg) per compartment
Rear center compartment: 500 pounds (226.80 kg)

REAR COMPARTMENT

The following compartment shall be supplied on the apparatus:

Compartment "B1":

There shall be one (1) compartment installed at the rear of the apparatus with a R·O·M Series IV roll up door.

The interior dimensions of this compartment shall be approximately 41.50 inches (1054.10 mm) wide by 39.50 inches (1003.30 mm) high by 33.63 inches (854.08 mm) deep.

Clear door opening dimensions shall be 33.50" (850.90 mm) wide by 31.80" (807.72 mm) high.

DOOR OPEN INDICATOR

The rear compartment roll up door shall have an integral door open indicator magnet in the lift bar. If the bar is not properly closed and the parking brake is released, it shall activate the hazard light in the cab to alert the crew.

ROLL-UP DOOR PROTECTOR

There shall be a protective cover installed under the rear compartment door roll to protect the door in the rolled up position.

ROLL-UP DOOR PROTECTOR FINISHING

The cover shall be fabricated of smooth aluminum and of Natural finish.

METRO FIRE APPARATUS

ROLL-UP DOOR CONSTRUCTION

All horizontal and vertical side compartment doors shall be roll-up style doors.

REAR COMPARTMENT DOOR

A R•O•M Corporation Series IV roll-up shutter door shall be installed. Each shutter slat, track, bottom rail, and drip rail shall be constructed from anodized 6063 T6 aluminum.

Shutter slats shall feature a double wall extrusion 0.315 inches thick with a concave interior surface to minimize loose equipment jamming the shutter door closed. Shutter slats shall feature an interlocking end shoe to prevent side to side binding of the shutter door during operation. Slat inner seal shall be a one piece PVC extrusion; seal design shall be such to prevent metal to metal contact while minimizing dirt and water from entering the compartment.

Shutter door track shall be one piece design with integral overlapping flange to provide a clean finished look without the need of caulk. Door track shall feature an extruded Santoprene rubber double lip low profile side seal with a silicone co-extruded back to reduce friction during shutter operation.

Shutter bottom rail shall be a one piece double wall extrusion with integrated finger pull. Finger pull shall be curved upward with a linear striated surface to improve operator grip while operating the shutter door. Bottom rail shall have a smooth contoured interior surface to prevent loose equipment from jamming the shutter door. Bottom rail seal shall be made from Santoprene; it will be a double "V" seal to prevent water and debris from entering compartment. Bottom rail lift bar shall be a one piece "D" shaped aluminum extrusion with linear striations to improve operator grip during operation. Lift bar shall have a wall thickness of 0.125 inches. Lift bar shall be supported by no less than two pivot blocks; pivot blocks shall be constructed from Type 66 Glass filled reinforced nylon for superior strength. Bottom rail end blocks shall have incorporated drain holes which will allow any moisture that collects inside the extrusion to drain out.

Shutter door shall have an enclosed counter balance system. Counter balance system shall be 4.00 inches in diameter and held in place by 2 heavy duty 18 gauge zinc plated plates. Counter balance system shall have 2 over-molded rubber guide wheels to provide a smooth transition from vertical track to counter balance system.

SIDE COMPARTMENT DOOR/TRACK/TRIM WET PAINTED

The side compartment doors, track, and trim shall be aluminum finish and wet painted to color match the apparatus body.

REAR COMPARTMENT DOOR/TRACK/TRIM WET PAINTED

The rear compartment door, track and trim shall be aluminum finish and wet painted to color match the apparatus body.

ROLL-UP DOOR PROTECTORS

There shall be a protective cover installed under each body side compartment door roll to protect the door in the rolled up position.

ROLL-UP DOOR PROTECTORS FINISHING

Each cover shall be fabricated of smooth aluminum and of Natural finish.

METRO FIRE APPARATUS

ROLL-UP DOOR ASSIST STRAPS

There shall be nylon straps installed on the both left and right side body side, 'high side' compartment doors, to assist in closing the door. The strap shall be attached to each door and shall be permanently mounted to the rearward wall with footman loops using Nutserts, half way between the top and bottom of the compartment.

DOOR OPEN INDICATOR

Each roll up door shall have an integral door open indicator magnet in the lift bar.

If the bar is not properly closed and the parking brake is released, it shall activate the hazard light in the cab to alert the crew.

COMPARTMENT LIGHTING

Two (2) OnScene Access LED strip lights shall be installed in each body compartment.

The tube lights shall be centered vertically along each side of the door framing and shall be maximum length available to fit the opening.

The lights in each compartment shall be on a separate circuit, turning on only those lights that have open compartment doors. The lights shall not be tied into the park brake control.

HOSE STORAGE

A hose bed shall be provided that meets the minimum NFPA storage requirements. The hose bed shall have slotted .25 inch (6.35 mm) aluminum flooring installed to allow drainage through the tank cavity to the ground below.

The aluminum flooring shall be manufactured in discrete sections to allow for easy removal and outstanding stability. The area shall be free of sharp edges to protect the hose when loaded or distributed.

HOSE BED FINISH

The apparatus hose bed interior walls shall be incorporated with a brushed stainless steel overlay material.

HOSE BED DIVIDER WITH HAND CUTOUT

There shall be a full height adjustable hose bed divider provided and installed in the hose bed area of the apparatus body.

The divider shall be fabricated of .25 inch (6.35 mm) thick aluminum plate with a double sided reinforcement and attached to the adjustable slide rails. The rear of the divider shall have a radius to provide a smooth corner and a hand cut out to aid in access to the hose bed area. Hose payout shall be unobstructed by the divider.

There shall be a total of two (2) provided and installed in the hose bed.

HOSEBED RISER

A 15.00 inch (381.00 mm) hosebed riser made from the same material as the body shall be provided in order to increase the hosebed capacity.

There shall be a red reflective stripe installed at the top of the hosebed riser sides.

METRO FIRE APPARATUS

CATWALKS

Catwalks shall be provided over the top of the compartments. The catwalks shall be manufactured with .125 inch (3.18 mm) embossed aluminum diamond plate material.

The outboard edge shall be bent downward at a 90 degree angle and over the compartments on both sides.

Catwalks shall not be an approved stepping surface, "Do not walk" labels to be installed

'A' FRAME HOSEBED COVER

There shall be a double door cover provided and installed which overlays a tubular structure for the hosebed.

Each cover shall be capable of supporting 600 pounds (272 kg) while standing on the cover. Each cover shall be capable of being opened independently and rest on a tubular structure which runs down the middle of the hose bed with a truss support at the rear of the apparatus. The covers in the closed position shall be higher in the center of the hose bed than they are at the hinged end to create an 'A' frame appearance and to aid in water runoff.

The front of the hose bed covers shall have vertical end caps that extend down to create a level line of diamond plate the width of the covers.

The doors shall be fabricated of .125 inch (3.18 mm) embossed aluminum diamond plate with full length two-piece stainless steel piano hinges.

The hosebed covers shall be wired to the hazard light in chassis cab. Inductive proximity switches shall be installed at the hosebed cover door hinges. If the door is not properly closed and the parking brake is released, it shall activate the "hazard light" in the cab to alert the crew.

MANUAL RAISED COVERS

Each cover shall be raised independently and manually. There shall be a gas strut installed on each cover to assist in opening the covers. Each gas shock shall be accompanied by a vinyl covered safety chain. There shall be a mechanical hold-open device to hold each cover in the open position at the front of the hosebed covers.

REAR OF A-FRAME HANDRAILS

Two (2) 1.25-inch diameter handrails constructed of extruded aluminum with a knurled grip full length red reflective stripe with 18.00 inches of grip surface shall be installed on the rear face of the A-Frame structure at the rear of the hosebed.

FRONT OF COVER ILLUMINATED HANDRAILS

Two (2) handrails shall be installed on the front vertical flanges of the hose bed covers, one (1) each cover. The handrails shall be constructed of 1.25-inch diameter extruded aluminum with a knurled grip full length red reflective stripe and full length illuminated LED light strip and shall be up to 18.00 inches (457.20 mm) in length.

Each handrail LED light strip specified shall be white/clear in color.

FRONT COVER ILLUMINATED HANDRAIL LIGHTING ACTIVATION

The illuminated handrail light shall be activated when the park brake and marker light activation to match chassis.

REAR HOSE BED COVER

The cover that extends down over the rear of the hose bed shall be supplied and installed by the Dealership prior to the

METRO FIRE APPARATUS

apparatus being placed into service.

HOSEBED COVER LIGHTING

Two (2) OnScene "Access" LED strip light shall be mounted to the underside of each hosebed cover. Each light shall be 48.00 inches each, evenly spaced from front to back.

The lights on each side shall be on a separate circuit and activate only when the covers are opened.

DUNNAGE AREA

A vertical bulkhead shall be installed at the front of the hose bed area, just behind the water tank fill tower, forming a storage area that is separated from the hose bed. The rear face of the bulkhead shall serve as a mounting surface for the hose bed dividers, resulting in the ability to move any hose bed divider across the entire width of the hose bed.

The floor of the dunnage area shall be constructed of non-slip .188 inch (4.76 mm) embossed aluminum diamond plate. The floor shall be slotted to allow drainage through the tank cavity to the ground below. The area shall be free of sharp edges to protect equipment when loading and unloading.

POLYPRENE TANK

The booster tank shall be constructed of .50 inch (12.70 mm), .75 inch (19.05 mm), and 1.00 inch (25.40 mm) thick polypropylene sheet stock which is a non-corrosive stress relieved thermoplastic. It shall be designed to be completely independent of the body and compartments. All joints and seams are extrusion welded and/or contain the "Bent Edge" and tested for maximum strength and integrity. The top of the booster tank is fitted with lifting eyes designed with a 3 to 1 safety factor to facilitate tank removal.

COVER

The tank cover shall be constructed of .75 inch (19.05 mm) thick Polyprene and shall be recessed. A minimum of two lifting dowels shall be drilled and tapped .50 inch (12.70 mm) x 2.00 inch (50.80 mm) to accommodate the lifting eyes.

BAFFLES

The swash partitions are manufactured of .50 inch (12.70 mm) Polyprene. All partitions are equipped with vent and air holes to permit movement of air and water between compartments to provide to provide maximum water flow. All swash partitions interlock and are welded to one another as well as to the walls of the tank.

MOUNTING

The tank shall rest on the sub-frame cross members with an unsupported area not to exceed 530 square inches (.34 square meters) on tanks up to 40.00 inches (1016.00 mm) in height. On tanks over 40.00 inches (1016.00 mm) in height, an unsupported area of not more than 400 square inches (.26 square meters) must be maintained.

All tanks shall be isolated from those cross members with a minimum of 2.00 inch (50.80 mm) x .25 inch (6.35 mm) hard rubber strips that are 60 durometer in hardness. The tank shall sit cradle mounted in the under body sub-frame and shall be completely removable without disturbing the body side panels.

TANK CAPACITY

The tank shall be 750 gallons (2839 liters) in capacity.

METRO FIRE APPARATUS

FILL TOWER

The fill opening shall be approximately 14.00 inches (355.00 mm) x 14.00 inches (355.00 mm).

The tower will have a .25 inch (6.35 mm) thick removable poly material screen and hinged type cover that will open if the tank is filled at an excess rate. There shall be a removable .25 inch (6.35 mm) thick poly material screen to prevent debris from falling into the tank.

The fill tower shall have a 6.00 inch (150.00 mm) overflow that will discharge underneath the tank, behind the rear wheels. The overflow shall terminate above the tank water level when filled to the rated capacity.

LADDER STORAGE

The ground ladders shall be stored within a compartment installed on the right side of the apparatus booster tank, with ladders lying on their side. There shall be storage for two (2) standard head pike poles and a slot for a back board integrated into the compartment. There shall be a non-metal ladder stop to prevent metal to metal contact. There shall be non-metallic guides installed for ladders to slide on.

All items shall be stored in their own independent section to allow one item to be removed without disturbing another.

The compartment and door shall be fabricated of .125 inch (3.18 mm) smooth aluminum.

The door shall be vertically hinged on the outboard edge (right side) and provided with two push button style latches and a chrome handle centered between the push button latches. The door shall have retro-reflective striping in a chevron pattern.

If the door is not properly closed and the parking brake is released, it shall activate the hazard light in the cab to alert the crew.

GROUND LADDERS

The following ground ladders shall be provided by the manufacturer:

- One (1) Duo-Safety 24 foot (7 m) two (2) section aluminum extension ladder, model 900A.
- One (1) Duo-Safety 14 foot (4 m) aluminum roof ladder with folding hooks, model 775A.
- One (1) Duo-Safety 10 foot (3 m) aluminum attic ladder, model 585A.

BODY OVERLAYS – FRONT/REAR

The entire front face of the apparatus body shall have aluminum diamond plate overlays installed. The entire rear face of the apparatus body shall have raw aluminum overlays installed for the installation of chevron striping.

All overlay materials shall be coated with 3M adhesive sealant on the back portion to provide an insulating barrier between dissimilar metals.

WHEEL WELL ROLL-OUT DRAWER

There shall be a roll-out drawer installed in the compartment located above the rear wheel on the left side of the body in the L-2 compartment. The slide assemblies shall incorporate cadmium plated ball bearing roller slides and a lock-in, lock-out front drawer release system (FDR).

The drawer shall be approximately 25.00 inch (635.00 mm) deep by 63.15 inch (1604.01 mm) wide with 2.75 inch (69.85 mm) tall sides and have a 300.00 pound (136.08 kg) capacity.

METRO FIRE APPARATUS

SCBA COMPARTMENT BIN

There shall be an eight (8) place air bottle compartment bin provided in the lower portion of the compartment located above the wheel well area on the right side in the R-2 compartment.

The interior surface of each SCBA storage tube shall be lined with a coating of gray Superliner. The application of Superliner shall aid to minimize any damage caused to the canisters while stored in the holders.

The NFPA required SCBA bottle straps shall be mounted deeper in the compartment, so the bottles do not hit the door when the door is closed.

OVERWHEEL SHELVING

One (1) shelf 66.25 inch (1682.75 mm) wide x 11.50 inch (292.10 mm) deep x 2.00 inch (50.80 mm) high shall be provided in the left side wheel well compartment.

The shelf shall be .19 inch (4.76 mm) smooth aluminum with a formed 2.00 inch (50.80 mm) lip on the front and back. The side mounting brackets shall be integral with the shelf to form the sides.

One (1) shelf 66.25 inch (1682.75 mm) wide x 11.50 inch (292.10 mm) deep x 2.00 inch (50.80 mm) high shall be provided in the right side wheel well compartment as part of the SCBA storage assembly.

The shelf shall be .19 inch (4.76 mm) smooth aluminum with a formed 2.00 inch (50.80 mm) lip on the front and back. The side mounting brackets shall be integral with the shelf to form the sides.

COMPARTMENT UNISTRUT

Vertically mounted Unistrut shall be installed in ALL compartments of the apparatus body to accommodate mounting shelves, trays, and other miscellaneous equipment items as specified.

SHELVING

The shelving shall be made out of .190 inch (4.83 mm) smooth aluminum sheet material with a formed 2.00 inch (50.80 mm) lip on the front and back.

The side mounting brackets shall be integral with the shelving to form the sides. The shelving shall be vertically adjustable.

The following shelving shall be provided:

UPPER HALF DEPTH SHELVING

A full width x half depth shelf shall be provided and installed in the upper compartment(s) specified.

There shall be a total quantity of three (3) provided.

One (1) shall be located in the L-3 compartment.

One (1) shall be located in the R-1 compartment.

One (1) shall be located in the R-3 compartment.

SHELF DEPTH MODIFICATION

The shelf specified above shall be reduced in depth by 1.00 inch (25.40 mm) for installation of wall mount tool boards.

METRO FIRE APPARATUS

FULL DEPTH SHELVING

A full width x full depth shelf shall be provided and installed in the compartment(s) as specified.

There shall be a total quantity of one (1) provided.
One (1) shall be located in the L-1 compartment.

SHELF AND TRAY FINISH

Any shelf or roll-out tray installed shall have a dual-action sanded finish applied on the front and side faces.

WHEEL WELL PANELS

The body panel area around the wheel well on each side of the body shall be painted the same color as the rest of the body

SIDE RUB RAILS

The bottom edge of the body compartments and pump compartment shall be protected with rub rails to absorb minor damage while protecting the body. The rear rub rails shall be full length to the end of the tailboard.

The rub rails shall be fabricated of brightly anodized aluminum channel. The rub rails shall be bolted in place with stainless steel bolts and shall be spaced away from the body with .50 inch (12.70 mm) nylon spacers to help prevent the collection of water and debris. Each rub rail section shall be easily removable and replaced should it become damaged.

REAR RUB RAILS

The rearward edge of the rear step shall be trimmed with rub rails to absorb minor damage while protecting the body.

The rub rails shall be fabricated of brightly anodized aluminum channel. The rub rails shall be bolted in place with stainless steel bolts and shall be spaced away from the body with .50 inch (12.70 mm) nylon spacers to help prevent the collection of water and debris. Each rub rail section shall be easily removable and replaced should it become damaged.

RUB RAIL RETRO-REFLECTIVE STRIPING

One inch retro-reflective Diamond Grade striping shall be applied to the length of each rub rail section making the perimeter of the apparatus more readily visible.

STRIPE COLOR

The reflective striping shall be red in color.

DOOR SILL TRIM PLATES

Brushed stainless steel door sill plates shall be installed at the bottom of each body compartment door opening.

VERTICAL OVERLAY TRIM PLATES

Full height brushed stainless steel vertical overlay trim plates shall be installed on the outer corners of the front and back body compartments.

METRO FIRE APPARATUS

FENDERETTES

Two (2) polished aluminum fenderettes shall be provided and installed on body rear wheel well openings, one (1) each side. Rubber welting shall be provided between the body and the crown to seal the seam and restrict moisture from entering. A dielectric barrier shall be provided between the fender crown fasteners (screws) and the fender sheet metal to resist deterioration.

REAR TAILBOARD

The rear tailboard shall be fabricated of the same materials as used in the apparatus body. The tailboard shall be an independent assembly fastened to the rear body structural framing to provide body protection and a solid rear stepping platform.

The rear of the apparatus body shall be vertical in design - otherwise known as a 'flat-back'. On the rear body surface, a sign shall be attached that states: "DO NOT RIDE ON REAR STEP, DEATH OR SERIOUS INJURY MAY RESULT."

The rear tailboard and body shall be constructed such that the angle of departure shall be no less than 8 degrees at the rear of the apparatus when fully loaded (Per NFPA 1901, current edition).

REAR TAILBOARD STEP

The rear tailboard shall be approximately 17.50 inches (444.50 mm) deep and shall incorporate a .125 inch (3.175 mm) embossed aluminum diamond plate overlay.

The stepping area shall span the width of the apparatus, overlapping the perimeter of the structural tailboard framework.

The embossed diamond plate material shall meet the minimum NFPA standard requirements for slip resistance.

INTERMEDIATE REAR STEP

The rear step shall be 53.38 inches (1355.73 mm) wide by 10.00 inches (254.00 mm) in depth. There shall be up to four (4) handhold cutouts provided in the top step surface measuring approximately 2.50 inches deep. There shall be one (1) full length aluminum non lit handrail integrated into the assembly.

The step shall be mounted on the flat back of the apparatus with gusset-type mounting and 5/16" bolts to provide sufficient support for loading hose and gaining access to the hose bed area.

The platform stepping surface shall be constructed of .188 inch (4.76 mm) embossed aluminum diamond plate materials.

INTERMEDIATE STEP LIGHTING

Two (2) Whelen OS lights shall be installed to illuminate the stepping area.

Additionally, there shall be one (1) On-Scene Access 38" LED tube light installed below the intermediate step to illuminate below the step.

STEP LIGHT ACTIVATION

The step lights shall be activated when the park brake is set.

FOLDING STEPS

Innovative Controls Inc. model #3004234 steps, made of high strength die cast aluminum, conforming to current NFPA requirements, shall be provided and installed on the apparatus as specified.

METRO FIRE APPARATUS

The steps shall include a molded gasket and drain at the bottom to allow any water to escape the assembly, preventing water ingress and keeping the mount from damaging painted surfaces.

The steps shall be mounted with 5/16" bolts.

The steps shall have a minimum of 46 sq. inches of surface area capable of sustaining a 1200 lb. static load. The steps shall be mounted no more than 18" inches between each step.

ILLUMINATED FOLDING STEPS

Three (3) illuminated folding steps shall be installed on the left front vertical face of the body.

STEP LIGHT ACTIVATION

The step lights shall be activated when the park brake is set.

10" HANDRAILS

One (1) handrail constructed of extruded aluminum with a knurled grip, full length red reflective strip and full length illuminated LED light strip shall be installed to assist in climbing the steps according to NFPA 1901, current edition. There shall be a 2.00 inch minimum clearance between the bracket and the body.

Location: Front edge of catwalk, angled at approximately 30 degrees.

ILLUMINATED FOLDING STEPS

Three (3) illuminated folding steps shall be installed on the right front vertical face of the body.

STEP LIGHT ACTIVATION

The step lights shall be activated when the park brake is set.

10" HANDRAILS

One (1) handrail constructed of extruded aluminum with a knurled grip, full length red reflective strip and full length illuminated LED light strip shall be installed to assist in climbing the steps according to NFPA 1901, current edition. There shall be a 2.00 inch minimum clearance between the bracket and the body.

Location: Front edge of catwalk, angled at approximately 30 degrees.

ILLUMINATED FOLDING STEPS

Three (3) illuminated folding steps shall be installed on the right rear vertical face of the body.

STEP LIGHT ACTIVATION

The step lights shall be activated when the park brake is set.

HANDRAILS KNURLED ALUMINUM ILLUMINATED

Handrails shall be 1.25 inches in diameter, constructed of extruded aluminum with a knurled grip, full length red reflective strip and full length illuminated LED light strip.

There shall be a 2.00 inch minimum clearance between the handrail and the body. The light shall illuminate an area adjacent to the handrail and in accordance with (NFPA) 1901, Standard for Automotive Fire Apparatus, standard

METRO FIRE APPARATUS

requirements.

Each handrail LED light strip specified shall be white/clear in color.

The following handrails shall be installed at the approximate lengths noted:

REAR HANDRAIL LOCATION

Two (2) full height vertical handrails shall be mounted, one (1) on each side of the rear center compartment area at the rear of the apparatus. The vertical rear of body handrails shall be mounted with offset stanchions.

PUMP MODULE HAND RAILS

Two (2) handrails shall be installed parallel to the body on top the pump house, between the crosslay and operator panel, one (1) each side.

REAR TOW EYES

There shall be two (2) rear tow eyes installed on the rear sub frame support structure, one each side. The location of the tow eyes shall be below the rear center compartment. The tow eyes shall be manufactured of 1.00 inch plate steel that is bolted to the chassis frame rail with a minimum of 6 grade 8 bolts.

PAINT SPECIFICATIONS

All bright metal fittings, if unavailable in stainless steel, shall be heavily chrome plated.

Critical body and sub-frame area which cannot be primed after assembly shall be pre-painted.

All welded metal surfaces shall be ground to a smooth surface prior to a degreasing and high pressure, high temperature phosphatizing process. The entire surface shall be sprayed with a non-chromate sealing compound to prevent formulation of stains or flash rust on previously phosphatized parts.

The paint applied to the apparatus shall be Akzo Nobel, Sikkens brand, LVBT650 basecoat, applied throughout a multi-step process including at least two coats of each color and clear coat finish.

The coating shall be an infra-red, baked air dried. The coatings shall provide full gloss finished suitable for application by high-pressure airless or conventional low pressure air atomizing spray.

The coatings shall not contain lead, cadmium or arsenic. The polyisocyanate component shall consist of only aliphatic isocyanates, with no portion being aromatic isocyanates in character. The solvents used in all components and products shall not contain ethylene glycol mono-ethyl ethers or their acetates (commercially recognized as cello solves), nor shall they contain any chlorinated hydrocarbons. The products shall have no adverse effects on the health or nor present any unusual hazard to personnel when used according to manufacturer's recommendations for handling and proper protective safety equipment, and for its intended use.

The coating system, as supplied and recommended for application, shall meet all applicable federal, state and local laws and regulations now in force or at any time during the courses of the bid.

The manufacturer shall supply (upon request) for each product and component of the system, a properly complete OSHA "Safety Data Sheet".

The following documents of the issue in effect on the date of the invitation to quote form a part of this document to the extent specified herein:

METRO FIRE APPARATUS

Federal Standards: Number 141A and 141B paint, varnish, lacquer and related material: methods of inspection, sampling, and testing.

Military Standard: MIL-C 83486B Coating, Urethane, Aliphatic Isocyanates, for Aerospace applications.

Industry Methods and Standards: ASTM Method of Analysis (American Society for testing and Materials). BMS 10-72A (Boeing Material Specifications).

The entire exterior body structure (excluding roll-up doors) shall receive the primer coats and the finish coats. The apparatus body will be painted in a down draft type paint booth to reduce dust, dirt or impurities in the finish paint. The painted surfaces shall have a finish with no runs, sags, craters, pinholes or other defects. The coating will meet the following test performance properties as a minimum standard.

The apparatus shall be painted Sikkens FLNA 32528 Red

SPEEDLINER COMPARTMENT FINISH

The compartment interiors shall be coated with bed liner type spray.

COMPARTMENT FINISH COLOR

The Superliner Color shall be Medium Gray.

LOW-VOLTAGE ELECTRICAL SYSTEM

The apparatus shall be equipped with a Weldon Logic Controlled, Low-Voltage (12v) Electrical System compliant with the latest revision of the NFPA 1901 guideline.

The system shall be capable of performing total load management, load management sequencing, and load shedding via continuous monitoring of the low-voltage electrical system. In addition, the system shall be capable of switching loads (like operating as an emergency warning lamp flasher) eliminating the dependency on many archaic electrical components such as conventional flasher modules. The system shall also incorporate provisions for future expansion or modification.

The low-voltage electrical system shall be designed to distribute the placement of electrical system hardware throughout the apparatus thereby enabling a smaller, optimized wire harness. The programmable, logic controlled system shall eliminate redundant electrical hardware such as harnesses, circuit boards, relays, circuit breakers, and separate electrical or interlock subsystems and associated electronics for controlling various electrical loads and inputs.

As-built electrical system drawings and a vehicle-specific reference of I/O shall be furnished in the delivery manuals. These drawings shall show the electrical system broken down into separate functions, or small groups of related functions. Drawings shall depict circuit numbers, electrical components and connectors from beginning to end. A single drawing for all electrical circuits installed by the apparatus builder shall not be accepted.

LED PERIMETER LIGHTS

There shall be six (6) LED TecNiq model T44 series, 4.00 inch round, 8 diode LED lights installed on the apparatus. One (1) under each side at the front of the body, one (1) under each side at the rear of the body and one (1) each side under the rear tailboard. The lights shall be positioned to provide illumination to the immediate ground area around the unit.

PERIMETER LIGHTS ACTIVATION

The underbody perimeter lights shall be activated with activation of the chassis ground lights.

METRO FIRE APPARATUS

LED DOT LIGHTING

There shall be seven (7) lights located on the rear of the vehicle. Three (3) of the lights shall be mounted on the upper rear face of the body just below the hosebed area in a cluster for use as identification lamps. Two (2) lights shall be located outboard on the upper rear, one each side for use as clearance lamps and two (2) lights in the rearmost position of the side rubrail on the tailboard facing the side for use as rear side marker lamps

The lights shall be TecNiq brand S17 series LED red markers

DOT ADDITIONAL MARKER LIGHTS

There shall be two (2) amber LED intermediate marker lights/intermediate turn signals installed in the rub rail, forward of the rear wheel well, one (1) each side.

The lights shall be TecNiq brand S17 series LED amber markers/turn.

INTERMEDIATE MARKER LIGHTS

The intermediate amber side marker lights installed in the rub rail, forward of the rear wheel well, shall flash when their respective side turn signal is activated. The lights shall return to steady burn when turn signal is deactivated.

UPPER LIGHTING PACKAGE

The following NFPA lighting package, manufactured by Whelen, shall be supplied and installed in the upper areas of the vehicle.

The body shall have the warning light dimming feature when the chassis is equipped with it. If the dimming feature is not provided on the chassis, the body WILL NOT be equipped.

UPPER ZONE C:

There shall be two (2) Whelen model L31H beacons with 360 degree LED lights, provided and installed on the apparatus.

One (1) each side on the rear upper outboard corners of the apparatus.

REAR WARNING LIGHTS COLOR

The upper warning lights mounted at the rear shall be red with clear lenses.

AUXILIARY UPPER ZONE C:

There shall be two (2) Whelen model M6 series LED lights with chrome bezels, one (1) each side, provided and installed on the back of the fabricated tread plate scene light box.

REAR WARNING LIGHTS FLASH

The rear upper lights shall feature multiple flash patterns including steady burn for solid colors and multiple flash patterns for split colors. The lights shall be programmed to emit the "TripleFlash 75" solid flash pattern.

REAR WARNING LIGHTS COLOR

The upper warning lights mounted at the rear shall be amber with a clear lens.

METRO FIRE APPARATUS

UPPER REAR WARNING LIGHT SWITCH E-MASTER/VISTA

The upper rear warning lights shall be controlled through the master warning switch and a secondary rear warning switch located on the Vista display control screen. The switches shall be clearly labeled for ease of identification.

UPPER ZONE B&D

There shall be four (4) Whelen WION lights with chrome bezels installed, two (2) on each side. One (1) light shall be located in the upper section of the side compartment header centered above the forward and rearmost compartments.

UPPER SIDE WARNING LIGHTS FLASH

The upper side lights shall feature multiple flash patterns including steady burn.

UPPER SIDE WARNING LIGHTS COLOR

The upper side warning lights mounted on the cab front positions shall be red with clear lenses.

LOWER LED WARNING LIGHTING

The following NFPA lighting package, manufactured by Whelen, shall be supplied and installed in the lower areas of the vehicle.

The body shall have the warning light dimming feature when the chassis is equipped with it. If the dimming feature is not provided on the chassis, the body WILL NOT be equipped.

LOWER ZONE B&D:

There shall be four (4) Whelen model M6 series LED lights with chrome bezels, two (2) each side, provided and installed with the apparatus.

SIDE WARNING LIGHTS FLASH

The lower side lights shall feature multiple flash patterns including steady burn for solid colors and multiple flash patterns for split colors. The lights shall be programmed to emit the "TripleFlash 75 in/out" solid flash pattern.

SIDE WARNING LIGHTS COLOR

The lower side warning lights mounted on the side positions shall be red with clear lenses.

SIDE WARNING LIGHTS LOCATION

The warning lights on the side of the apparatus shall be mounted at the mid height in the forward area of the rear wheel well panel and at the rear tailboard location.

AUXILIARY WARNING LIGHTS LOWER ZONE B&D

There shall be four (4) auxiliary Whelen WION series LED lights with chrome bezels installed, two (2) each side in the pump house running board.

The front light shall be centered under the walkway step and the rear light shall be centered under the hose storage cavity.

METRO FIRE APPARATUS

SIDE WARNING LIGHTS FLASH

The lower front lights shall feature multiple flash patterns including steady burn for solid colors and multiple flash patterns for split colors.

SIDE WARNING LIGHTS COLOR

The lower side warning lights mounted on the side positions shall be red with clear lenses.

LOWER ZONES B&D CAST ALUMINUM LIGHT HOUSING WITH PAINTED INSERT

A cast aluminum light housing with painted outward facing inserts, shall be installed for the rearmost warning light in zones B&D. The housing will ensure the light is mounted as far rearward as possible.

The inserts shall be painted to color match the body.

LOWER SIDE WARNING LIGHT SWITCH E-MASTER/VISTA

The lower side warning lights shall be controlled through the master warning switch and a secondary side warning switch located on the Vista display control screen. The switches shall be clearly labeled for ease of identification.

LOWER ZONE C:

There shall be two (2) Whelen model M9 series Super-LED lights with chrome bezels, one (1) each side, on provided and installed on the rear of the body.

REAR WARNING LIGHTS FLASH

The lower rear lights shall feature multiple flash patterns including steady burn for solid colors and multiple flash patterns for split colors. The lights shall be programmed to emit the "Triple Flash 75 in/out" flash pattern.

REAR WARNING LIGHTS COLOR

The lower rear warning lights mounted at the rear shall be red with clear lenses.

REAR WARNING LIGHT ACTIVATION

The rear lower warning lights shall be activated by the master warning switch, and individually switched by a virtual switch on the vista screen in the cab by a "lower rear warning lights" switch.

LED REAR TAIL LIGHT ASSEMBLY

There shall be Whelen M9-Series Super LED rear tail light assemblies provided and installed with the apparatus, one (1) each side at the rear.

The following shall be installed in the order as specified from top to bottom:

- One (1) Warning light called out above
- One (1) #M9BTT LED red brake light
- One (1) #M9T LED series amber turn signal light
- One (1) #M9 BUW LED clear backup light

METRO FIRE APPARATUS

MOUNTING FLANGES

There shall be individual chrome bezels provided for each light of the taillight assembly.

BACKUP LIGHTS

The backup lights shall illuminate when the apparatus is placed in reverse.

REAR DIRECTIONAL LIGHTBAR

There shall be eight (8) rear directional lights provided and installed on the rear of the apparatus integrated to the rear face of hosebed cover vertical end cap.

The lights shall be Whelen model #WIONSMCA LED ION amber lights with clear lenses and black bezels, and mounted equally spaced, four (4) lights on each end cap.

The back of the hose bed cap shall be boxed in to provide protection and strength for the lights. The back of the protection panel shall be angled to provide protection when hose is deployed in case of contact. This protection panel shall be constructed of smooth aluminum.

The controller shall be located and installed in the Chassis.

RDL BLACK VINYL

There shall be a non-reflective black vinyl provided around the perimeter of the rear directional lights. The vinyl shall be applied to a smooth surface material.

REAR VIEW CAMERA SYSTEM

The chassis provided camera shall be surface mounted under the intermediate step, on the center rear of the apparatus body for maximum viewing capability.

SIDE SCENE LIGHTING

Two (2) Whelen Pioneer PCH2 with flood and spotlight, housing shall be powder-coated white.

The scene lights shall be located on the side of the body, one (1) on each side, at the rear corner of the body side walls.

SIDE SCENE LIGHT MOUNTING

The light shall be mounted at zero degrees in the side of the treadbrite box which also houses the upper rear warning light on the rear face of the box.

The treadplate box shall be as short as possible from the catwalk to the top of the scene light and shall be as wide as the catwalk.

SIDE SCENE LIGHT ACTIVATION

The side scene lights shall be activated by the two (2) virtual buttons on the Vista display control screen for the chassis side scene lights, one (1) chassis provided switch on the officer switch panel for the right scene only, and two (2) switches on the pump panel, one (1) labeled for each side of the body.

The switches shall be labeled as follows:

METRO FIRE APPARATUS

Left Scene

Right Scene

REAR SCENE LIGHTING

There shall be two (2) scene lights installed at the rear body panels, one (1) on each side.

The scene lights shall be Whelen model #M9LZC 12 volt scene lights with chrome bezels. The lights shall offer LED directional lighting from 2 to 40-degrees with internal and external optics.

The lights shall draw 6.0 amps and generate 6,500 lumens.

REAR SCENE LIGHT ACTIVATION

The rear scene lights shall be activated by one (1) virtual button on the Vista display control screen, one (1) switch on the officer switch panel, one (1) switch on the pump panel, and when the apparatus transmission is shifted into reverse.

The switch shall be labeled as follows:

Rear Scene

REFLECTIVE STRIPING

The reflective stripe applied to the outside perimeter of the chassis and apparatus as directed by the Fire Department shall be applied by the Dealership prior to the truck being placed into service.

REAR RETRO-REFLECTIVE CHEVRON STRIPING

The rear of body (excluding rear door) shall be equipped with Diamond Grade, retro-reflective striping in a chevron pattern, sloping downward and away from the centerline of the vehicle at an angle of 45-degrees.

The stripe shall be 6.00 inch (152.40 mm) wide alternating in colors in compliance with the current edition of (NFPA) 1901, Standard for Automotive Fire Apparatus.

RETRO-REFLECTIVE CHEVRON STRIPING

Diamond Grade retro-reflective chevron striping shall be applied to the front bumper.

CHEVRON COLORS

The retro-reflective chevron striping shall be red and fluorescent yellow-green in color.

BODY LETTERING

The lettering shall be provided and installed on each side of the apparatus body as directed by the Fire Department by the Dealership.

LICENSE PLATE BRACKET

A Cast Products, model LP0005-1-C, cast aluminum open bottom license plate bracket shall be installed on the apparatus.

The bracket shall incorporate a clear LED (WL0501) light to illuminate the license plate to meet DOT requirements.

METRO FIRE APPARATUS

LICENSE PLATE BRACKET LOCATION

The above specified license plate bracket shall be installed at the back of the apparatus on the right side. The bracket shall be mounted to meet all applicable DOT standards.

WHEEL CHOCKS

One (1) set of NFPA compliant wheel chocks shall be provided and installed by the Dealership before the truck is placed into service.

RECHARGEABLE FLASHLIGHTS

All NFPA required portable hand lights will be supplied and installed by the Fire Department before the truck is placed into service.

NFPA LOOSE EQUIPMENT

The Fire Department shall be responsible to provide all NFPA loose equipment.

**Solicitation Number: RFP #113021****CONTRACT**

This Contract is between Sourcewell, 202 12th Street Northeast, P.O. Box 219, Staples, MN 56479 (Sourcewell) and Rev Group, Inc., 245 S. Executive Dr., Suite 100, Brookfield, WI 53005 (Supplier).

Sourcewell is a State of Minnesota local government unit and service cooperative created under the laws of the State of Minnesota (Minnesota Statutes Section 123A.21) that offers cooperative procurement solutions to government entities. Participation is open to eligible federal, state/province, and municipal governmental entities, higher education, K-12 education, nonprofit, tribal government, and other public entities located in the United States and Canada. Sourcewell issued a public solicitation for Firefighting Apparatus and Fire Service Vehicles from which Supplier was awarded a contract.

Supplier desires to contract with Sourcewell to provide equipment, products, or services to Sourcewell and the entities that access Sourcewell's cooperative purchasing contracts (Participating Entities).

1. TERM OF CONTRACT

- A. **EFFECTIVE DATE.** This Contract is effective upon the date of the final signature below.
- B. **EXPIRATION DATE AND EXTENSION.** This Contract expires February 10, 2026, unless it is cancelled sooner pursuant to Article 22. This Contract may be extended one additional year upon the request of Sourcewell and written agreement by Supplier.
- C. **SURVIVAL OF TERMS.** Notwithstanding any expiration or termination of this Contract, all payment obligations incurred prior to expiration or termination will survive, as will the following: Articles 11 through 14 survive the expiration or cancellation of this Contract. All other rights will cease upon expiration or termination of this Contract.

2. EQUIPMENT, PRODUCTS, OR SERVICES

- A. **EQUIPMENT, PRODUCTS, OR SERVICES.** Supplier will provide the Equipment, Products, or Services as stated in its Proposal submitted under the Solicitation Number listed above.

Supplier's Equipment, Products, or Services Proposal (Proposal) is attached and incorporated into this Contract.

All Equipment and Products provided under this Contract must be new and the current model. Supplier may offer close-out, refurbished, or remounted Equipment or Products if they are clearly indicated in Supplier's product and pricing list. Unless agreed to by the Participating Entities in advance, Equipment or Products must be delivered as operational to the Participating Entity's site.

This Contract offers an indefinite quantity of sales, and while substantial volume is anticipated, sales and sales volume are not guaranteed.

B. **WARRANTY.** Supplier warrants that all Equipment, Products, and Services furnished are free from liens and encumbrances, and are free from defects in design, materials, and workmanship. In addition, Supplier warrants the Equipment, Products, and Services are suitable for and will perform in accordance with the ordinary use for which they are intended. Supplier's dealers and distributors must agree to assist the Participating Entity in reaching a resolution in any dispute over warranty terms with the manufacturer. Any manufacturer's warranty that extends beyond the expiration of the Supplier's warranty will be passed on to the Participating Entity.

C. **DEALERS, DISTRIBUTORS, AND/OR RESELLERS.** Upon Contract execution and throughout the Contract term, Supplier must provide to Sourcewell a current means to validate or authenticate Supplier's authorized dealers, distributors, or resellers relative to the Equipment, Products, and Services offered under this Contract, which will be incorporated into this Contract by reference. It is the Supplier's responsibility to ensure Sourcewell receives the most current information.

3. PRICING

All Equipment, Products, or Services under this Contract will be priced at or below the price stated in Supplier's Proposal.

When providing pricing quotes to Participating Entities, all pricing quoted must reflect a Participating Entity's total cost of acquisition. This means that the quoted cost is for delivered Equipment, Products, and Services that are operational for their intended purpose, and includes all costs to the Participating Entity's requested delivery location.

Regardless of the payment method chosen by the Participating Entity, the total cost associated with any purchase option of the Equipment, Products, or Services must always be disclosed in the pricing quote to the applicable Participating Entity at the time of purchase.

A. **SHIPPING AND SHIPPING COSTS.** All delivered Equipment and Products must be properly packaged. Damaged Equipment and Products may be rejected. If the damage is not readily

apparent at the time of delivery, Supplier must permit the Equipment and Products to be returned within a reasonable time at no cost to Sourcewell or its Participating Entities. Participating Entities reserve the right to inspect the Equipment and Products at a reasonable time after delivery where circumstances or conditions prevent effective inspection of the Equipment and Products at the time of delivery. In the event of the delivery of nonconforming Equipment and Products, the Participating Entity will notify the Supplier as soon as possible and the Supplier will replace nonconforming Equipment and Products with conforming Equipment and Products that are acceptable to the Participating Entity.

Supplier must arrange for and pay for the return shipment on Equipment and Products that arrive in a defective or inoperable condition.

Sourcewell may declare the Supplier in breach of this Contract if the Supplier intentionally delivers substandard or inferior Equipment or Products.

B. SALES TAX. Each Participating Entity is responsible for supplying the Supplier with valid tax-exemption certification(s). When ordering, a Participating Entity must indicate if it is a tax-exempt entity.

C. HOT LIST PRICING. At any time during this Contract, Supplier may offer a specific selection of Equipment, Products, or Services at discounts greater than those listed in the Contract. When Supplier determines it will offer Hot List Pricing, it must be submitted electronically to Sourcewell in a line-item format. Equipment, Products, or Services may be added or removed from the Hot List at any time through a Sourcewell Price and Product Change Form as defined in Article 4 below.

Hot List program and pricing may also be used to discount and liquidate close-out and discontinued Equipment and Products as long as those close-out and discontinued items are clearly identified as such. Current ordering process and administrative fees apply. Hot List Pricing must be published and made available to all Participating Entities.

4. PRODUCT AND PRICING CHANGE REQUESTS

Supplier may request Equipment, Product, or Service changes, additions, or deletions at any time. All requests must be made in writing by submitting a signed Sourcewell Price and Product Change Request Form to the assigned Sourcewell Supplier Development Administrator. This approved form is available from the assigned Sourcewell Supplier Development Administrator. At a minimum, the request must:

- Identify the applicable Sourcewell contract number;
- Clearly specify the requested change;
- Provide sufficient detail to justify the requested change;

- Individually list all Equipment, Products, or Services affected by the requested change, along with the requested change (e.g., addition, deletion, price change); and
- Include a complete restatement of pricing documentation in Microsoft Excel with the effective date of the modified pricing, or product addition or deletion. The new pricing restatement must include all Equipment, Products, and Services offered, even for those items where pricing remains unchanged.

A fully executed Sourcewell Price and Product Change Request Form will become an amendment to this Contract and will be incorporated by reference.

5. PARTICIPATION, CONTRACT ACCESS, AND PARTICIPATING ENTITY REQUIREMENTS

A. PARTICIPATION. Sourcewell's cooperative contracts are available and open to public and nonprofit entities across the United States and Canada; such as federal, state/province, municipal, K-12 and higher education, tribal government, and other public entities.

The benefits of this Contract should be available to all Participating Entities that can legally access the Equipment, Products, or Services under this Contract. A Participating Entity's authority to access this Contract is determined through its cooperative purchasing, interlocal, or joint powers laws. Any entity accessing benefits of this Contract will be considered a Service Member of Sourcewell during such time of access. Supplier understands that a Participating Entity's use of this Contract is at the Participating Entity's sole convenience and Participating Entities reserve the right to obtain like Equipment, Products, or Services from any other source.

Supplier is responsible for familiarizing its sales and service forces with Sourcewell contract use eligibility requirements and documentation and will encourage potential participating entities to join Sourcewell. Sourcewell reserves the right to add and remove Participating Entities to its roster during the term of this Contract.

B. PUBLIC FACILITIES. Supplier's employees may be required to perform work at government-owned facilities, including schools. Supplier's employees and agents must conduct themselves in a professional manner while on the premises, and in accordance with Participating Entity policies and procedures, and all applicable laws.

6. PARTICIPATING ENTITY USE AND PURCHASING

A. ORDERS AND PAYMENT. To access the contracted Equipment, Products, or Services under this Contract, a Participating Entity must clearly indicate to Supplier that it intends to access this Contract; however, order flow and procedure will be developed jointly between Sourcewell and Supplier. Typically, a Participating Entity will issue an order directly to Supplier or its authorized subsidiary, distributor, dealer, or reseller. If a Participating Entity issues a purchase order, it may use its own forms, but the purchase order should clearly note the applicable Sourcewell

contract number. All Participating Entity orders under this Contract must be issued prior to expiration or cancellation of this Contract; however, Supplier performance, Participating Entity payment obligations, and any applicable warranty periods or other Supplier or Participating Entity obligations may extend beyond the term of this Contract.

Supplier's acceptable forms of payment are included in its attached Proposal. Participating Entities will be solely responsible for payment and Sourcewell will have no liability for any unpaid invoice of any Participating Entity.

B. **ADDITIONAL TERMS AND CONDITIONS/PARTICIPATING ADDENDUM.** Additional terms and conditions to a purchase order, or other required transaction documentation, may be negotiated between a Participating Entity and Supplier, such as job or industry-specific requirements, legal requirements (e.g., affirmative action or immigration status requirements), or specific local policy requirements. Some Participating Entities may require the use of a Participating Addendum; the terms of which will be negotiated directly between the Participating Entity and the Supplier. Any negotiated additional terms and conditions must never be less favorable to the Participating Entity than what is contained in this Contract.

C. **SPECIALIZED SERVICE REQUIREMENTS.** In the event that the Participating Entity requires service or specialized performance requirements not addressed in this Contract (such as e-commerce specifications, specialized delivery requirements, or other specifications and requirements), the Participating Entity and the Supplier may enter into a separate, standalone agreement, apart from this Contract. Sourcewell, including its agents and employees, will not be made a party to a claim for breach of such agreement.

D. **TERMINATION OF ORDERS.** Participating Entities may terminate an order, in whole or in part, immediately upon notice to Supplier in the event of any of the following events:

1. The Participating Entity fails to receive funding or appropriation from its governing body at levels sufficient to pay for the equipment, products, or services to be purchased; or
2. Federal, state, or provincial laws or regulations prohibit the purchase or change the Participating Entity's requirements.

E. **GOVERNING LAW AND VENUE.** The governing law and venue for any action related to a Participating Entity's order will be determined by the Participating Entity making the purchase.

7. CUSTOMER SERVICE

A. **PRIMARY ACCOUNT REPRESENTATIVE.** Supplier will assign an Account Representative to Sourcewell for this Contract and must provide prompt notice to Sourcewell if that person is changed. The Account Representative will be responsible for:

- Maintenance and management of this Contract;
- Timely response to all Sourcwell and Participating Entity inquiries; and
- Business reviews to Sourcwell and Participating Entities, if applicable.

B. BUSINESS REVIEWS. Supplier must perform a minimum of one business review with Sourcwell per contract year. The business review will cover sales to Participating Entities, pricing and contract terms, administrative fees, sales data reports, supply issues, customer issues, and any other necessary information.

8. REPORT ON CONTRACT SALES ACTIVITY AND ADMINISTRATIVE FEE PAYMENT

A. CONTRACT SALES ACTIVITY REPORT. Each calendar quarter, Supplier must provide a contract sales activity report (Report) to the Sourcwell Supplier Development Administrator assigned to this Contract. Reports are due no later than 45 days after the end of each calendar quarter. A Report must be provided regardless of the number or amount of sales during that quarter (i.e., if there are no sales, Supplier must submit a report indicating no sales were made).

The Report must contain the following fields:

- Participating Entity Name (e.g., City of Staples Highway Department);
- Participating Entity Physical Street Address;
- Participating Entity City;
- Participating Entity State/Province;
- Participating Entity Zip/Postal Code;
- Participating Entity Contact Name;
- Participating Entity Contact Email Address;
- Participating Entity Contact Telephone Number;
- Sourcwell Assigned Entity/Participating Entity Number;
- Item Purchased Description;
- Item Purchased Price;
- Sourcwell Administrative Fee Applied; and
- Date Purchase was invoiced/sale was recognized as revenue by Supplier.

B. ADMINISTRATIVE FEE. In consideration for the support and services provided by Sourcwell, the Supplier will pay an administrative fee to Sourcwell on all Equipment, Products, and Services provided to Participating Entities. The Administrative Fee must be included in, and not added to, the pricing. Supplier may not charge Participating Entities more than the contracted price to offset the Administrative Fee.

The Supplier will submit payment to Sourcwell for the percentage of administrative fee stated in the Proposal multiplied by the total sales of all Equipment, Products, and Services purchased

by Participating Entities under this Contract during each calendar quarter. Payments should note the Supplier's name and Sourcewell-assigned contract number in the memo; and must be mailed to the address above "Attn: Accounts Receivable" or remitted electronically to Sourcewell's banking institution per Sourcewell's Finance department instructions. Payments must be received no later than 45 calendar days after the end of each calendar quarter.

Supplier agrees to cooperate with Sourcewell in auditing transactions under this Contract to ensure that the administrative fee is paid on all items purchased under this Contract.

In the event the Supplier is delinquent in any undisputed administrative fees, Sourcewell reserves the right to cancel this Contract and reject any proposal submitted by the Supplier in any subsequent solicitation. In the event this Contract is cancelled by either party prior to the Contract's expiration date, the administrative fee payment will be due no more than 30 days from the cancellation date.

9. AUTHORIZED REPRESENTATIVE

Sourcewell's Authorized Representative is its Chief Procurement Officer.

Supplier's Authorized Representative is the person named in the Supplier's Proposal. If Supplier's Authorized Representative changes at any time during this Contract, Supplier must promptly notify Sourcewell in writing.

10. AUDIT, ASSIGNMENT, AMENDMENTS, WAIVER, AND CONTRACT COMPLETE

A. **AUDIT.** Pursuant to Minnesota Statutes Section 16C.05, subdivision 5, the books, records, documents, and accounting procedures and practices relevant to this Agreement are subject to examination by Sourcewell or the Minnesota State Auditor for a minimum of six years from the end of this Contract. This clause extends to Participating Entities as it relates to business conducted by that Participating Entity under this Contract.

B. **ASSIGNMENT.** Neither party may assign or otherwise transfer its rights or obligations under this Contract without the prior written consent of the other party and a fully executed assignment agreement. Such consent will not be unreasonably withheld. Any prohibited assignment will be invalid.

C. **AMENDMENTS.** Any amendment to this Contract must be in writing and will not be effective until it has been duly executed by the parties.

D. **WAIVER.** Failure by either party to take action or assert any right under this Contract will not be deemed a waiver of such right in the event of the continuation or repetition of the circumstances giving rise to such right. Any such waiver must be in writing and signed by the parties.

E. **CONTRACT COMPLETE.** This Contract represents the complete agreement between the parties. No other understanding regarding this Contract, whether written or oral, may be used to bind either party. For any conflict between the attached Proposal and the terms set out in Articles 1-22 of this Contract, the terms of Articles 1-22 will govern.

F. **RELATIONSHIP OF THE PARTIES.** The relationship of the parties is one of independent contractors, each free to exercise judgment and discretion with regard to the conduct of their respective businesses. This Contract does not create a partnership, joint venture, or any other relationship such as master-servant, or principal-agent.

11. INDEMNITY AND HOLD HARMLESS

Supplier must indemnify, defend, save, and hold Sourcewell and its Participating Entities, including their agents and employees, harmless from any claims or causes of action, including attorneys' fees incurred by Sourcewell or its Participating Entities, arising out of any act or omission in the performance of this Contract by the Supplier or its agents or employees; this indemnification includes injury or death to person(s) or property alleged to have been caused by some defect in the Equipment, Products, or Services under this Contract to the extent the Equipment, Product, or Service has been used according to its specifications. Sourcewell's responsibility will be governed by the State of Minnesota's Tort Liability Act (Minnesota Statutes Chapter 466) and other applicable law.

12. GOVERNMENT DATA PRACTICES

Supplier and Sourcewell must comply with the Minnesota Government Data Practices Act, Minnesota Statutes Chapter 13, as it applies to all data provided by or provided to Sourcewell under this Contract and as it applies to all data created, collected, received, stored, used, maintained, or disseminated by the Supplier under this Contract.

13. INTELLECTUAL PROPERTY, PUBLICITY, MARKETING, AND ENDORSEMENT

A. INTELLECTUAL PROPERTY

1. *Grant of License.* During the term of this Contract:
 - a. Sourcewell grants to Supplier a royalty-free, worldwide, non-exclusive right and license to use the trademark(s) provided to Supplier by Sourcewell in advertising and promotional materials for the purpose of marketing Sourcewell's relationship with Supplier.
 - b. Supplier grants to Sourcewell a royalty-free, worldwide, non-exclusive right and license to use Supplier's trademarks in advertising and promotional materials for the purpose of marketing Supplier's relationship with Sourcewell.
2. *Limited Right of Sublicense.* The right and license granted herein includes a limited right of each party to grant sublicenses to their respective subsidiaries, distributors, dealers,

resellers, marketing representatives, and agents (collectively “Permitted Sublicensees”) in advertising and promotional materials for the purpose of marketing the Parties’ relationship to Participating Entities. Any sublicense granted will be subject to the terms and conditions of this Article. Each party will be responsible for any breach of this Article by any of their respective sublicensees.

3. Use; Quality Control.

- a. Neither party may alter the other party’s trademarks from the form provided and must comply with removal requests as to specific uses of its trademarks or logos.
- b. Each party agrees to use, and to cause its Permitted Sublicensees to use, the other party’s trademarks only in good faith and in a dignified manner consistent with such party’s use of the trademarks. Upon written notice to the breaching party, the breaching party has 30 days of the date of the written notice to cure the breach or the license will be terminated.

4. As applicable, Supplier agrees to indemnify and hold harmless Sourcewell and its Participating Entities against any and all suits, claims, judgments, and costs instituted or recovered against Sourcewell or Participating Entities by any person on account of the use of any Equipment or Products by Sourcewell or its Participating Entities supplied by Supplier in violation of applicable patent or copyright laws.

5. Termination. Upon the termination of this Contract for any reason, each party, including Permitted Sublicensees, will have 30 days to remove all Trademarks from signage, websites, and the like bearing the other party’s name or logo (excepting Sourcewell’s pre-printed catalog of suppliers which may be used until the next printing). Supplier must return all marketing and promotional materials, including signage, provided by Sourcewell, or dispose of it according to Sourcewell’s written directions.

B. **PUBLICITY.** Any publicity regarding the subject matter of this Contract must not be released without prior written approval from the Authorized Representatives. Publicity includes notices, informational pamphlets, press releases, research, reports, signs, and similar public notices prepared by or for the Supplier individually or jointly with others, or any subcontractors, with respect to the program, publications, or services provided resulting from this Contract.

C. **MARKETING.** Any direct advertising, marketing, or offers with Participating Entities must be approved by Sourcewell. Send all approval requests to the Sourcewell Supplier Development Administrator assigned to this Contract.

D. **ENDORSEMENT.** The Supplier must not claim that Sourcewell endorses its Equipment, Products, or Services.

14. GOVERNING LAW, JURISDICTION, AND VENUE

The substantive and procedural laws of the State of Minnesota will govern this Contract. Venue for all legal proceedings arising out of this Contract, or its breach, must be in the appropriate state court in Todd County, Minnesota or federal court in Fergus Falls, Minnesota.

15. FORCE MAJEURE

Neither party to this Contract will be held responsible for delay or default caused by acts of God or other conditions that are beyond that party's reasonable control. A party defaulting under this provision must provide the other party prompt written notice of the default.

16. SEVERABILITY

If any provision of this Contract is found by a court of competent jurisdiction to be illegal, unenforceable, or void then both parties will be relieved from all obligations arising from that provision. If the remainder of this Contract is capable of being performed, it will not be affected by such determination or finding and must be fully performed.

17. PERFORMANCE, DEFAULT, AND REMEDIES

A. **PERFORMANCE.** During the term of this Contract, the parties will monitor performance and address unresolved contract issues as follows:

1. *Notification.* The parties must promptly notify each other of any known dispute and work in good faith to resolve such dispute within a reasonable period of time. If necessary, Sourcewell and the Supplier will jointly develop a short briefing document that describes the issue(s), relevant impact, and positions of both parties.
2. *Escalation.* If parties are unable to resolve the issue in a timely manner, as specified above, either Sourcewell or Supplier may escalate the resolution of the issue to a higher level of management. The Supplier will have 30 calendar days to cure an outstanding issue.
3. *Performance while Dispute is Pending.* Notwithstanding the existence of a dispute, the Supplier must continue without delay to carry out all of its responsibilities under the Contract that are not affected by the dispute. If the Supplier fails to continue without delay to perform its responsibilities under the Contract, in the accomplishment of all undisputed work, the Supplier will bear any additional costs incurred by Sourcewell and/or its Participating Entities as a result of such failure to proceed.

B. **DEFAULT AND REMEDIES.** Either of the following constitutes cause to declare this Contract, or any Participating Entity order under this Contract, in default:

1. Nonperformance of contractual requirements, or
2. A material breach of any term or condition of this Contract.

The party claiming default must provide written notice of the default, with 30 calendar days to cure the default. Time allowed for cure will not diminish or eliminate any liability for liquidated or other damages. If the default remains after the opportunity for cure, the non-defaulting party may:

- Exercise any remedy provided by law or equity, or
- Terminate the Contract or any portion thereof, including any orders issued against the Contract.

18. INSURANCE

A. REQUIREMENTS. At its own expense, Supplier must maintain insurance policy(ies) in effect at all times during the performance of this Contract with insurance company(ies) licensed or authorized to do business in the State of Minnesota having an "AM BEST" rating of A- or better, with coverage and limits of insurance not less than the following:

1. *Workers' Compensation and Employer's Liability.*

Workers' Compensation: As required by any applicable law or regulation.

Employer's Liability Insurance: must be provided in amounts not less than listed below:

Minimum limits:

\$500,000 each accident for bodily injury by accident

\$500,000 policy limit for bodily injury by disease

\$500,000 each employee for bodily injury by disease

2. *Commercial General Liability Insurance.* Supplier will maintain insurance covering its operations, with coverage on an occurrence basis, and must be subject to terms no less broad than the Insurance Services Office ("ISO") Commercial General Liability Form CG0001 (2001 or newer edition), or equivalent. At a minimum, coverage must include liability arising from premises, operations, bodily injury and property damage, independent contractors, products-completed operations including construction defect, contractual liability, blanket contractual liability, and personal injury and advertising injury. All required limits, terms and conditions of coverage must be maintained during the term of this Contract.

Minimum Limits:

\$1,000,000 each occurrence Bodily Injury and Property Damage

\$1,000,000 Personal and Advertising Injury

\$2,000,000 aggregate for Products-Completed operations

\$2,000,000 general aggregate

3. *Commercial Automobile Liability Insurance.* During the term of this Contract, Supplier will maintain insurance covering all owned, hired, and non-owned automobiles in limits of liability not less than indicated below. The coverage must be subject to terms

no less broad than ISO Business Auto Coverage Form CA 0001 (2010 edition or newer), or equivalent.

Minimum Limits:

\$1,000,000 each accident, combined single limit

4. *Umbrella Insurance*. During the term of this Contract, Supplier will maintain umbrella coverage over Employer's Liability, Commercial General Liability, and Commercial Automobile.

Minimum Limits:

\$2,000,000

5. *Network Security and Privacy Liability Insurance*. During the term of this Contract, Supplier will maintain coverage for network security and privacy liability. The coverage may be endorsed on another form of liability coverage or written on a standalone policy. The insurance must cover claims which may arise from failure of Supplier's security resulting in, but not limited to, computer attacks, unauthorized access, disclosure of not public data – including but not limited to, confidential or private information, transmission of a computer virus, or denial of service.

Minimum limits:

\$2,000,000 per occurrence

\$2,000,000 annual aggregate

Failure of Supplier to maintain the required insurance will constitute a material breach entitling Sourcewell to immediately terminate this Contract for default.

B. CERTIFICATES OF INSURANCE. Prior to commencing under this Contract, Supplier must furnish to Sourcewell a certificate of insurance, as evidence of the insurance required under this Contract. Prior to expiration of the policy(ies), renewal certificates must be mailed to Sourcewell, 202 12th Street Northeast, P.O. Box 219, Staples, MN 56479 or sent to the Sourcewell Supplier Development Administrator assigned to this Contract. The certificates must be signed by a person authorized by the insurer(s) to bind coverage on their behalf.

Failure to request certificates of insurance by Sourcewell, or failure of Supplier to provide certificates of insurance, in no way limits or relieves Supplier of its duties and responsibilities in this Contract.

C. ADDITIONAL INSURED ENDORSEMENT AND PRIMARY AND NON-CONTRIBUTORY INSURANCE CLAUSE. Supplier agrees to list Sourcewell and its Participating Entities, including their officers, agents, and employees, as an additional insured under the Supplier's commercial general liability insurance policy with respect to liability arising out of activities, "operations," or "work" performed by or on behalf of Supplier, and products and completed operations of Supplier. The policy provision(s) or endorsement(s) must further provide that coverage is

primary and not excess over or contributory with any other valid, applicable, and collectible insurance or self-insurance in force for the additional insureds.

D. **WAIVER OF SUBROGATION.** Supplier waives and must require (by endorsement or otherwise) all its insurers to waive subrogation rights against Sourcewell and other additional insureds for losses paid under the insurance policies required by this Contract or other insurance applicable to the Supplier or its subcontractors. The waiver must apply to all deductibles and/or self-insured retentions applicable to the required or any other insurance maintained by the Supplier or its subcontractors. Where permitted by law, Supplier must require similar written express waivers of subrogation and insurance clauses from each of its subcontractors.

E. **UMBRELLA/EXCESS LIABILITY/SELF-INSURED RETENTION.** The limits required by this Contract can be met by either providing a primary policy or in combination with umbrella/excess liability policy(ies), or self-insured retention.

19. COMPLIANCE

A. **LAWS AND REGULATIONS.** All Equipment, Products, or Services provided under this Contract must comply fully with applicable federal laws and regulations, and with the laws in the states and provinces in which the Equipment, Products, or Services are sold.

B. **LICENSES.** Supplier must maintain a valid and current status on all required federal, state/provincial, and local licenses, bonds, and permits required for the operation of the business that the Supplier conducts with Sourcewell and Participating Entities.

20. BANKRUPTCY, DEBARMENT, OR SUSPENSION CERTIFICATION

Supplier certifies and warrants that it is not in bankruptcy or that it has previously disclosed in writing certain information to Sourcewell related to bankruptcy actions. If at any time during this Contract Supplier declares bankruptcy, Supplier must immediately notify Sourcewell in writing.

Supplier certifies and warrants that neither it nor its principals are presently debarred, suspended, proposed for debarment, declared ineligible, or voluntarily excluded from programs operated by the State of Minnesota; the United States federal government or the Canadian government, as applicable; or any Participating Entity. Supplier certifies and warrants that neither it nor its principals have been convicted of a criminal offense related to the subject matter of this Contract. Supplier further warrants that it will provide immediate written notice to Sourcewell if this certification changes at any time.

21. PROVISIONS FOR NON-UNITED STATES FEDERAL ENTITY PROCUREMENTS UNDER UNITED STATES FEDERAL AWARDS OR OTHER AWARDS

Participating Entities that use United States federal grant or FEMA funds to purchase goods or services from this Contract may be subject to additional requirements including the procurement standards of the Uniform Administrative Requirements, Cost Principles and Audit Requirements for Federal Awards, 2 C.F.R. § 200. Participating Entities may have additional requirements based on specific funding source terms or conditions. Within this Article, all references to “federal” should be interpreted to mean the United States federal government. The following list only applies when a Participating Entity accesses Supplier’s Equipment, Products, or Services with United States federal funds.

A. **EQUAL EMPLOYMENT OPPORTUNITY.** Except as otherwise provided under 41 C.F.R. § 60, all contracts that meet the definition of “federally assisted construction contract” in 41 C.F.R. § 60-1.3 must include the equal opportunity clause provided under 41 C.F.R. §60-1.4(b), in accordance with Executive Order 11246, “Equal Employment Opportunity” (30 FR 12319, 12935, 3 C.F.R. §, 1964-1965 Comp., p. 339), as amended by Executive Order 11375, “Amending Executive Order 11246 Relating to Equal Employment Opportunity,” and implementing regulations at 41 C.F.R. § 60, “Office of Federal Contract Compliance Programs, Equal Employment Opportunity, Department of Labor.” The equal opportunity clause is incorporated herein by reference.

B. **DAVIS-BACON ACT, AS AMENDED (40 U.S.C. § 3141-3148).** When required by federal program legislation, all prime construction contracts in excess of \$2,000 awarded by non-federal entities must include a provision for compliance with the Davis-Bacon Act (40 U.S.C. § 3141-3144, and 3146-3148) as supplemented by Department of Labor regulations (29 C.F.R. § 5, “Labor Standards Provisions Applicable to Contracts Covering Federally Financed and Assisted Construction”). In accordance with the statute, contractors must be required to pay wages to laborers and mechanics at a rate not less than the prevailing wages specified in a wage determination made by the Secretary of Labor. In addition, contractors must be required to pay wages not less than once a week. The non-federal entity must place a copy of the current prevailing wage determination issued by the Department of Labor in each solicitation. The decision to award a contract or subcontract must be conditioned upon the acceptance of the wage determination. The non-federal entity must report all suspected or reported violations to the federal awarding agency. The contracts must also include a provision for compliance with the Copeland “Anti-Kickback” Act (40 U.S.C. § 3145), as supplemented by Department of Labor regulations (29 C.F.R. § 3, “Contractors and Subcontractors on Public Building or Public Work Financed in Whole or in Part by Loans or Grants from the United States”). The Act provides that each contractor or subrecipient must be prohibited from inducing, by any means, any person employed in the construction, completion, or repair of public work, to give up any part of the compensation to which he or she is otherwise entitled. The non-federal entity must report all suspected or reported violations to the federal awarding agency. Supplier must be in compliance with all applicable Davis-Bacon Act provisions.

C. CONTRACT WORK HOURS AND SAFETY STANDARDS ACT (40 U.S.C. § 3701-3708). Where applicable, all contracts awarded by the non-federal entity in excess of \$100,000 that involve the employment of mechanics or laborers must include a provision for compliance with 40 U.S.C. §§ 3702 and 3704, as supplemented by Department of Labor regulations (29 C.F.R. § 5). Under 40 U.S.C. § 3702 of the Act, each contractor must be required to compute the wages of every mechanic and laborer on the basis of a standard work week of 40 hours. Work in excess of the standard work week is permissible provided that the worker is compensated at a rate of not less than one and a half times the basic rate of pay for all hours worked in excess of 40 hours in the work week. The requirements of 40 U.S.C. § 3704 are applicable to construction work and provide that no laborer or mechanic must be required to work in surroundings or under working conditions which are unsanitary, hazardous or dangerous. These requirements do not apply to the purchases of supplies or materials or articles ordinarily available on the open market, or contracts for transportation or transmission of intelligence. This provision is hereby incorporated by reference into this Contract. Supplier certifies that during the term of an award for all contracts by Sourcewell resulting from this procurement process, Supplier must comply with applicable requirements as referenced above.

D. RIGHTS TO INVENTIONS MADE UNDER A CONTRACT OR AGREEMENT. If the federal award meets the definition of “funding agreement” under 37 C.F.R. § 401.2(a) and the recipient or subrecipient wishes to enter into a contract with a small business firm or nonprofit organization regarding the substitution of parties, assignment or performance of experimental, developmental, or research work under that “funding agreement,” the recipient or subrecipient must comply with the requirements of 37 C.F.R. § 401, “Rights to Inventions Made by Nonprofit Organizations and Small Business Firms Under Government Grants, Contracts and Cooperative Agreements,” and any implementing regulations issued by the awarding agency. Supplier certifies that during the term of an award for all contracts by Sourcewell resulting from this procurement process, Supplier must comply with applicable requirements as referenced above.

E. CLEAN AIR ACT (42 U.S.C. § 7401-7671Q.) AND THE FEDERAL WATER POLLUTION CONTROL ACT (33 U.S.C. § 1251-1387). Contracts and subgrants of amounts in excess of \$150,000 require the non-federal award to agree to comply with all applicable standards, orders or regulations issued pursuant to the Clean Air Act (42 U.S.C. § 7401- 7671q) and the Federal Water Pollution Control Act as amended (33 U.S.C. § 1251- 1387). Violations must be reported to the Federal awarding agency and the Regional Office of the Environmental Protection Agency (EPA). Supplier certifies that during the term of this Contract will comply with applicable requirements as referenced above.

F. DEBARMENT AND SUSPENSION (EXECUTIVE ORDERS 12549 AND 12689). A contract award (see 2 C.F.R. § 180.220) must not be made to parties listed on the government wide exclusions in the System for Award Management (SAM), in accordance with the OMB guidelines at 2 C.F.R. §180 that implement Executive Orders 12549 (3 C.F.R. § 1986 Comp., p. 189) and 12689 (3 C.F.R. § 1989 Comp., p. 235), “Debarment and Suspension.” SAM Exclusions contains the names

of parties debarred, suspended, or otherwise excluded by agencies, as well as parties declared ineligible under statutory or regulatory authority other than Executive Order 12549. Supplier certifies that neither it nor its principals are presently debarred, suspended, proposed for debarment, declared ineligible, or voluntarily excluded from participation by any federal department or agency.

G. BYRD ANTI-LOBBYING AMENDMENT, AS AMENDED (31 U.S.C. § 1352). Suppliers must file any required certifications. Suppliers must not have used federal appropriated funds to pay any person or organization for influencing or attempting to influence an officer or employee of any agency, a member of Congress, officer or employee of Congress, or an employee of a member of Congress in connection with obtaining any federal contract, grant, or any other award covered by 31 U.S.C. § 1352. Suppliers must disclose any lobbying with non-federal funds that takes place in connection with obtaining any federal award. Such disclosures are forwarded from tier to tier up to the non-federal award. Suppliers must file all certifications and disclosures required by, and otherwise comply with, the Byrd Anti-Lobbying Amendment (31 U.S.C. § 1352).

H. RECORD RETENTION REQUIREMENTS. To the extent applicable, Supplier must comply with the record retention requirements detailed in 2 C.F.R. § 200.333. The Supplier further certifies that it will retain all records as required by 2 C.F.R. § 200.333 for a period of 3 years after grantees or subgrantees submit final expenditure reports or quarterly or annual financial reports, as applicable, and all other pending matters are closed.

I. ENERGY POLICY AND CONSERVATION ACT COMPLIANCE. To the extent applicable, Supplier must comply with the mandatory standards and policies relating to energy efficiency which are contained in the state energy conservation plan issued in compliance with the Energy Policy and Conservation Act.

J. BUY AMERICAN PROVISIONS COMPLIANCE. To the extent applicable, Supplier must comply with all applicable provisions of the Buy American Act. Purchases made in accordance with the Buy American Act must follow the applicable procurement rules calling for free and open competition.

K. ACCESS TO RECORDS (2 C.F.R. § 200.336). Supplier agrees that duly authorized representatives of a federal agency must have access to any books, documents, papers and records of Supplier that are directly pertinent to Supplier's discharge of its obligations under this Contract for the purpose of making audits, examinations, excerpts, and transcriptions. The right also includes timely and reasonable access to Supplier's personnel for the purpose of interview and discussion relating to such documents.

L. PROCUREMENT OF RECOVERED MATERIALS (2 C.F.R. § 200.322). A non-federal entity that is a state agency or agency of a political subdivision of a state and its contractors must comply with Section 6002 of the Solid Waste Disposal Act, as amended by the Resource Conservation

and Recovery Act. The requirements of Section 6002 include procuring only items designated in guidelines of the Environmental Protection Agency (EPA) at 40 C.F.R. § 247 that contain the highest percentage of recovered materials practicable, consistent with maintaining a satisfactory level of competition, where the purchase price of the item exceeds \$10,000 or the value of the quantity acquired during the preceding fiscal year exceeded \$10,000; procuring solid waste management services in a manner that maximizes energy and resource recovery; and establishing an affirmative procurement program for procurement of recovered materials identified in the EPA guidelines.

M. FEDERAL SEAL(S), LOGOS, AND FLAGS. The Supplier not use the seal(s), logos, crests, or reproductions of flags or likenesses of Federal agency officials without specific pre-approval.

N. NO OBLIGATION BY FEDERAL GOVERNMENT. The U.S. federal government is not a party to this Contract or any purchase by an Participating Entity and is not subject to any obligations or liabilities to the Participating Entity, Supplier, or any other party pertaining to any matter resulting from the Contract or any purchase by an authorized user.

O. PROGRAM FRAUD AND FALSE OR FRAUDULENT STATEMENTS OR RELATED ACTS. The Contractor acknowledges that 31 U.S.C. 38 (Administrative Remedies for False Claims and Statements) applies to the Supplier's actions pertaining to this Contract or any purchase by a Participating Entity.

P. FEDERAL DEBT. The Supplier certifies that it is non-delinquent in its repayment of any federal debt. Examples of relevant debt include delinquent payroll and other taxes, audit disallowance, and benefit overpayments.

Q. CONFLICTS OF INTEREST. The Supplier must notify the U.S. Office of General Services, Sourcewell, and Participating Entity as soon as possible if this Contract or any aspect related to the anticipated work under this Contract raises an actual or potential conflict of interest (as described in 2 C.F.R. Part 200). The Supplier must explain the actual or potential conflict in writing in sufficient detail so that the U.S. Office of General Services, Sourcewell, and Participating Entity are able to assess the actual or potential conflict; and provide any additional information as necessary or requested.

R. U.S. EXECUTIVE ORDER 13224. The Supplier, and its subcontractors, must comply with U.S. Executive Order 13224 and U.S. Laws that prohibit transactions with and provision of resources and support to individuals and organizations associated with terrorism.

S. PROHIBITION ON CERTAIN TELECOMMUNICATIONS AND VIDEO SURVEILLANCE SERVICES OR EQUIPMENT. To the extent applicable, Supplier certifies that during the term of this Contract it will comply with applicable requirements of 2 C.F.R. § 200.216.

T. DOMESTIC PREFERENCES FOR PROCUREMENTS. To the extent applicable, Supplier certifies that during the term of this Contract will comply with applicable requirements of 2 C.F.R. § 200.322.

22. CANCELLATION

Sourcwell or Supplier may cancel this Contract at any time, with or without cause, upon 60 days' written notice to the other party. However, Sourcwell may cancel this Contract immediately upon discovery of a material defect in any certification made in Supplier's Proposal. Cancellation of this Contract does not relieve either party of financial, product, or service obligations incurred or accrued prior to cancellation.

Sourcwell

Rev Group, Inc.

DocuSigned by:
Jeremy Schwartz
By: C0FD2A139D06489...

Jeremy Schwartz
Title: Chief Procurement Officer
Date: 2/7/2022 | 9:18 PM CST

DocuSigned by:
Mike Virnig
By: F3DD8D32408047A...

Mike Virnig
Title: Vice President Sales, REV Fire Group
Date: 2/24/2022 | 3:15 PM CST

Approved:

DocuSigned by:
Chad Coauette
By: 7E42B8F817A64CC...

Chad Coauette
Title: Executive Director/CEO
Date: 2/24/2022 | 3:17 PM CST

RFP 113021 - Firefighting Apparatus and Fire Service Vehicles

Vendor Details

Company Name: E-ONE, Inc.
Does your company conduct business under any other name? If yes, please state: REV Fire Group
Address: 1601 SW 37th AVE
Ocala, FL 34474
Contact: Fred Cureton
Email: fred.cureton@revfiregroup.com
Phone: 352-895-0783
HST#: 59-1515283

Submission Details

Created On: Tuesday November 02, 2021 04:14:12
Submitted On: Tuesday November 30, 2021 16:23:32
Submitted By: Fred Cureton
Email: fred.cureton@revfiregroup.com
Transaction #: 95acac42-31d9-4719-9cb7-33441ff906f7
Submitter's IP Address: 192.222.31.157

Specifications

Table 1: Proposer Identity & Authorized Representatives

General Instructions (applies to all Tables) Sourcewell prefers a brief but thorough response to each question. Do not merely attach additional documents to your response without also providing a substantive response. Do not leave answers blank; respond "N/A" if the question does not apply to you (preferably with an explanation).

Line Item	Question	Response *
1	Proposer Legal Name (one legal entity only): (In the event of award, will execute the resulting contract as "Supplier")	REV GROUP, INC. (REV FIRE GROUP Division).
2	Identify all subsidiary entities of the Proposer whose equipment, products, or services are included in the Proposal.	E-ONE, INC., FERRARA FIRE APPARATUS, INC., KOVATCH MOBILE EQUIPMENT CORP., LADDER TOWER, SMEAL HOLDING LLC., SPARTAN FIRE, LLC., SPARTAN CHASSIS.
3	Identify all applicable assumed names or DBA names of the Proposer or Proposer's subsidiaries in Line 1 or Line 2 above.	REV FIRE GROUP, E-ONE, INC., FERRARA FIRE APPARATUS, KME FIRE APPARATUS, KOVATCH MOBILE EQUIPMENT CORP, LADDER TOWER, LTI, SMEAL HOLDING LLC., SMEAL FIRE APPARATUS, SPARTAN EMERGENCY VEHICLES, SPARTAN FIRE APPARATUS, SPARTAN FIRE, LLC., SPARTAN CHASSIS.
4	Proposer Physical Address:	REV Group, Inc. -245 S. EXECUTIVE DR., SUITE 100, BROOKFIELD, WI 53005 E-ONE, Inc. - 1601 SW 37th Ave., Ocala, FL. 34474 Ferrara Fire Apparatus - 27855 James Chapel Rd., Holden, LA 70744 KME Fire Apparatus - One Industrial Complex Nesquehoning, PA 18240 Spartan Fire, LLC. - 907 7th Ave North, Brandon, SD 57005 Smeal Holding LLC. - 610 W 4th St., Snyder, NE 68664 Ladder Tower - 68 Cocalico Creek Road, Ephrata, PA 17522 Spartan Chassis - 1541 Reynolds Rd, Charlotte, MI 48813
5	Proposer website address (or addresses):	REV Group, Inc. - www.revgroup.com REV FIRE GROUP - www.revgroup.com/rev-group-best-fire-truck-manufacturers E-ONE, Inc. - www.e-one.com Ferrara Fire Apparatus - www.ferrarafire.com KME Fire Apparatus - www.kmefire.com Spartan Fire, LLC, Smeal Holding LLC., Ladder Tower, and Spartan Chassis - www.spartaner.com
6	Proposer's Authorized Representative (name, title, address, email address & phone) (The representative must have authority to sign the "Proposer's Assurance of Compliance" on behalf of the Proposer and, in the event of award, will be expected to execute the resulting contract):	Mike Virnig, Vice President Sales, REV Fire Group 1601 SW 37th Ave., Ocala, FL 34474 mike.virnig@revfiregroup.com 352-861-3542 (Office), 562-587-1600 (Mobile)
7	Proposer's primary contact for this proposal (name, title, address, email address & phone):	Fred Cureton, National Contract Manager, REV Fire Group 1601 SW 37th Ave., Ocala, FL 34474 fred.cureton@revfiregroup.com 205-680-4468 (Office), 352-895-0783 (Mobile)

8	<p>Proposer's other contacts for this proposal, if any (name, title, address, email address & phone):</p>	<p>For E-ONE, Inc.;</p> <p>1601 SW 37th Ave., Ocala, FL 34474</p> <p>Fred Cureton, National Contract Manager, REV Fire Group fred.cureton@revfiregroup.com 205-680-4468 (Office), 352-895-0783 (Mobile)</p> <p>Larry Daniels, Director of Sales, ldaniels@revgroup.com, 352-861-3541</p> <p>For Ferrara Fire Apparatus:</p> <p>27855 James Chapel Rd., Holden, LA 70744</p> <p>Eric Adams, Apparatus Sales, erica@ferrarafire.com, 225-567-7100</p> <p>Jason Louque, Director of Sales, jasonl@ferrarafire.com, 225-567-7100</p> <p>For KME Fire Apparatus:</p> <p>One Industrial Complex Nesquehoning, PA 18240</p> <p>Anthony Maff, Senior Sales Support, tmaff@kmefire.com, 570-669-5595</p> <p>Chris McClung, Director of Sales, cmclung@kmefire.com, 352-502-6881</p> <p>For Spartan Fire LLC., Smeal Holdings, LLC., and Ladder Towers:</p> <p>907 7th Ave North, Brandon, SD 57005</p> <p>Nicole Sateran, Sales Assistant, nicole.sateran@spartanmotors.com, 402-218-2762</p> <p>Chris Wade, Director of Sales, chris.wade@spartanmotors.com, 404-218-2762</p> <p>For Spartan Chassis:</p> <p>Stephen Carleton, Manager of Sales and Training, Spartan Motors 1541 Reynolds Rd, Charlotte, MI 48813 stephen.carleton@spartanmotors.com 517-588-4704 (Office), 570-657-5557 (Mobile)</p>
---	---	--

Table 2: Company Information and Financial Strength

Line Item	Question	Response *
-----------	----------	------------

<p>9</p>	<p>Provide a brief history of your company, including your company's core values, business philosophy, and industry longevity related to the requested equipment, products or services.</p>	<p>REV Group® companies are leading designers and manufacturers of specialty vehicles and related aftermarket parts and services. Our companies serve a diversified customer base, primarily in the United States, through three segments: Fire & Emergency, Commercial, and Recreation. They provide customized vehicle solutions for applications, including essential needs for public services (ambulances, fire apparatus, school buses, and transit buses), commercial infrastructure (terminal trucks and industrial sweepers) and consumer leisure (recreational vehicles). REV's diverse portfolio is made up of well-established principal vehicle brands, including many of the most recognizable names within their industry. Several of our brands pioneered their specialty vehicle product categories and date back more than 50 years. REV Group trades on the NYSE under the symbol REVG.</p> <p>REV Group manufactures more than 20,000 specialty vehicles every year — a testament to the trust placed in our products.</p> <p>E-ONE, Inc. has been in business since 1974. Ferrara Fire Apparatus has been in business since 1987. KME Fire Apparatus has been in business since 1980 but it's founders had been in the transportation business since 1948. Spartan Fire, LLC./Spartan Chassis has been in business since 1975.</p> <p>Values: DO WHAT'S RIGHT - We act with integrity and transparency, always. We keep our commitments and earn trust through our actions. SAFETY IS LIFE - The safety of our people and those who travel in our vehicles is our top priority. It's more than the way we work, it's a way of life. For our employees this includes weekly safety bulletins, required protective clothing (steel toe shoes, safety classes, ear plugs, etc.), fall restraints, wellness health screenings, optional vision and dental coverage, optional long term illness coverage, and even optional pet coverage. For our end users, our products must be designed and built to meet current industry standard, must provide the level of firefighter safety in their design, must be of the highest quality offered in the industry, and must provide value for Sourcewell members. BUILD LASTING TRUST - Customers depend on our vehicles and support through the entire lifecycle of their purchase. We will build that trust through transparency and respect and by providing quality vehicles and attentive service. THINK LIKE AN OWNER - Each of us plays a vital role in our success. We innovate, execute and use our resources wisely to create value for our stakeholders. WIN AS ONE - We value diversity in our teams, respect alternative perspectives and are accountable to each other to fulfill our goals. We recognize employees for performance excellence by promoting from within when possible, recognizing our Veterans during annual luncheon, recognizing excellence thru attendance, and performing annual evaluations.</p> <p>Our brands are social responsible companies in that we support local community initiatives (parades, marathons, civic activities, fundraisers), and responding to emergencies caused by natural disasters.</p>
----------	---	---

<p>10</p>	<p>What are your company's expectations in the event of an award?</p>	<p>The REV Group's diversified portfolio of specialty products connects and protects communities around the clock and around the world with a lineup of vehicles that have long served the fire and emergency, commercial infrastructure and consumer leisure markets. Together, these vehicle brands have manufactured more than 300,000+ vehicles in service today — a bumper-to-bumper feat that stretches from New York City to Dallas. Among REV's lineup of brands, you'll find vehicles that help fight fires, transport patients to emergency rooms, move freight in the world's ports, offer mobility to people with disabilities, carry children safely from home to school and unite families across the country. It is the goal of the REV Group and our many specialty brands to provide Sourcewell members the largest selection of quality vehicles, options, and services of anyone in the industry. We will provide a working partnership with Sourcewell where together we can provide a one stop shop for purchase and servicing of critical safety and support vehicles.</p> <p>We welcome the opportunity to work with Sourcewell members to understand both current and future needs. This includes but is not limited to apparatus requirements, service requirements, training requirements, and parts/equipment requirements.</p> <p>We welcome the opportunity to work with Sourcewell members to develop custom designed value packages to meet/exceed communicated requirements from our diverse selection of proposed solutions.</p> <p>We commit to provide Sourcewell members timely responses to inquiries and follow up inquiries, to provide Sourcewell members high quality vehicle solutions designed to meet and/or exceed industry standards, to provide Sourcewell members products and services which are competitively priced, provide exceptional value, and extends the life cycle of their purchase, and to provide Sourcewell members unsurpassed "after the sale" service utilizing our worldwide dealer distribution network and supplier partners for parts, service, training, and sales support.</p>
-----------	---	--

11	<p>Demonstrate your financial strength and stability with meaningful data. This could include such items as financial statements, SEC filings, credit and bond ratings, letters of credit, and detailed reference letters. Upload supporting documents (as applicable) in the document upload section of your response.</p>	<p>See attached PDF named REV GROUP (REV Fire Group) Financial Strength and Stability.</p> <p>Press Release on financials (see also attached SEC filing and investor presentation).</p> <p>ROOKFIELD, Wis., September 08, 2021--(BUSINESS WIRE)--REV Group, Inc. (NYSE: REVG), a manufacturer of industry-leading specialty vehicles, today reported results for the three months ended July 31, 2021 ("third quarter 2021"). Consolidated net sales in the third quarter 2021 were \$593.3 million, representing an increase of 1.9% compared to \$582.2 million for the three months ended July 31, 2020 ("third quarter 2020"). The increase in consolidated net sales was primarily due to an increase in net sales in the Recreation and Commercial segments partially offset by a decrease in net sales in the Fire and Emergency ("F&E") segment.</p> <p>The company's third quarter 2021 net income was \$23.7 million, or \$0.36 per diluted share. Adjusted Net Income for the third quarter 2021 was \$24.5 million, or \$0.37 per diluted share, compared to Adjusted Net Income of \$6.3 million, or \$0.10 per diluted share, in the third quarter 2020. Adjusted EBITDA in the third quarter 2021 was \$41.6 million, compared to \$21.4 million in the third quarter 2020. The increase in Adjusted EBITDA during the quarter was driven by increased contribution from the F&E and Recreation segments partially offset by a decrease in the Commercial segment.</p> <p>Fire & Emergency Segment</p> <p>F&E segment net sales were \$269.5 million in the third quarter 2021, a decrease of \$37.2 million, or 12.1%, from \$306.7 million in the third quarter 2020. The decrease in net sales compared to the prior year quarter was primarily due to decreased shipments of fire apparatus and ambulances units compared to the prior year quarter related to supply chain disruption and labor constraints. F&E segment backlog at the end of the third quarter 2021 was \$1,229.5 million, an increase of \$189.8 million compared to \$1,039.7 million at the end of the third quarter 2020. The increase was primarily the result of continued strong demand and order intake for fire apparatus and ambulance units.</p> <p>F&E segment Adjusted EBITDA was \$15.8 million in the third quarter 2021, an increase of \$2.9 million, or 22.5%, from \$12.9 million in the third quarter 2020. Profitability within the segment benefited primarily from cost and efficiency improvements and lower selling, general and administrative ("SG&A") costs, partially offset by lower sales volume and inefficiencies resulting from supply chain disruptions and labor constraints.</p> <p>Working Capital, Liquidity, and Capital Allocation</p> <p>Cash and cash equivalents totaled \$9.2 million as of July 31, 2021. Net debt² was \$240.8 million, and the company had \$276.8 million available under its ABL revolving credit facility as of July 31, 2021, an increase of \$53.1 million as compared to the April 30, 2021 availability of \$223.1 million. Trade working capital³ for the company as of July 31, 2021 was \$405.5 million, compared to \$449.9 million as of July 31, 2020. The decrease was primarily due to decreased accounts receivable and decreased inventory partially offset by decreased payables. Capital expenditures in the third quarter 2021 were \$5.3 million compared to \$2.0 million in the third quarter 2020.</p> <p>Share Repurchase Program</p> <p>On September 2, 2021, the company's board of directors approved the authorization of a new share repurchase program that allows the repurchase of up to \$150.0 million of the company's outstanding common stock, effective immediately. The share repurchase authorization expires in 24 months and gives management the flexibility to determine conditions under which shares may be purchased.</p> <p>Quarterly Dividend</p> <p>The company's board of directors declared a quarterly cash dividend in the amount of \$0.05 per share of common stock, which equates to a rate of \$0.20 per share of common stock on an annualized basis, payable on October 15, 2021, to shareholders of record on September 30, 2021.</p>
12	<p>What is your US market share for the solutions that you are proposing?</p>	<p>REV Fire Group = 25.86% U.S, 25.39% North America</p>
13	<p>What is your Canadian market share for the solutions that you are proposing?</p>	<p>REV Fire Group = 20.00% Canada</p>

14	Has your business ever petitioned for bankruptcy protection? If so, explain in detail.	NO.	*
15	How is your organization best described: is it a manufacturer, a distributor/dealer/reseller, or a service provider? Answer whichever question (either a) or b) just below) best applies to your organization. a) If your company is best described as a distributor/dealer/reseller (or similar entity), provide your written authorization to act as a distributor/dealer/reseller for the manufacturer of the products proposed in this RFP. If applicable, is your dealer network independent or company owned? b) If your company is best described as a manufacturer or service provider, describe your relationship with your sales and service force and with your dealer network in delivering the products and services proposed in this RFP. Are these individuals your employees, or the employees of a third party?	We are best described as a manufacturer and service provider. In most cases dealers are contracted to represent our brands in designated/agreed territories (U.S., Canada, and International locations). These territories differ in size based on each dealership's capability. Dealers then provide sales, service, and parts support. Dealers issue purchase orders for requested products/services and resell these to the end user/member. Each dealer is an independent business and each have their own employees/facilities. Where dealers are under contract to represent our brands it is our expectation the Sourcewell member will issue purchase orders directly to our authorized dealer. These dealers are listed on the dealer list for each respective brand. There are two additional scenarios: 1. In cases where there is no dealer coverage each brand provides a direct company employee to manage the sales and service of customers/members in these areas. In these cases the contract will be thru the respective brand and the Sourcewell member would issue the purchase order directly to the brand. 2. In cases where the REV Group has local facilities, these employees are company employees who provide sales, service, and parts to customers/members within their area of responsibility. The Sourcewell member would issue their purchase order to the REV RTC facility just as it were an approved dealer.	*
16	If applicable, provide a detailed explanation outlining the licenses and certifications that are both required to be held, and actually held, by your organization (including third parties and subcontractors that you use) in pursuit of the business contemplated by this RFP.	License requirements vary across North America. The REV Group and its dealer representatives are expected to adhere to all requirements be it a business license, insurance requirements, sales representative licensing, or service technician certification.	*
17	Provide all "Suspension or Debarment" information that has applied to your organization during the past ten years.	N/A	*

Table 3: Industry Recognition & Marketplace Success

Line Item	Question	Response *	
18	Describe any relevant industry awards or recognition that your company has received in the past five years	E-ONE currently holds a Notice of ULC and/or NFPA Audit Completion and Authorization to Apply VIP Sticker issued December 30, 2015 for both the Ocala and Hamburg facilities, is ANAB accredited for International Management Systems certificate number IMS-0020, is ISO 9001:2015 certified with a certificate valid thru July 30 2024, and holds a 2021 FAMA Certificate of Membership. See the attached for additional detail. Gary Pacilio (E-ONE, Inc.) is on the 2021 FAMA Board of Directors as the Treasurer, Bert McCutcheon (Ferrara Fire Apparatus) is on the 2021 FAMA Board of Directors as the Director-at-Large, Roger Lackore (Spartan Fire, LLC) is the FAMA committee chair of the Technical Committee.	*
19	What percentage of your sales are to the governmental sector in the past three years	As it relates to fire apparatus, a very high percentage (probably 90% +). Most apparatus are sold to government, municipal, city, and county entities.	*
20	What percentage of your sales are to the education sector in the past three years	As it relates to fire apparatus; None in the formal education sector. We sometimes sell fire apparatus to support fire training academies but these are typically purchased through the municipal side of the business.	*

<p>21</p>	<p>List any state, provincial, or cooperative purchasing contracts that you hold. What is the annual sales volume for each of these contracts over the past three years?</p>	<p>As it relates to fire apparatus: Totals for REV Fire Group = \$555,579,245</p> <p>Sourcwell (Based on delivered units - E-ONE 2018=\$768,854, 2019 = \$1,604,379; E-ONE 2020 = \$7,314,034; E-ONE 2021 YTD = \$11,372,360 E-ONE has quoted a total of \$71,643,085 and booked \$58,812,849 or 82.09% of quoted. Ferrara has not delivered any apparatus sold thru Sourcwell. KME has not delivered any apparatus sold thru Sourcwell Spartan reports Sourcwell sales as follows: 2019 = \$28,992,914; 2020 = \$31,246,024; and 2021YTD = \$53,117,860</p> <p>Florida Sheriffs - Totals for REV Fire Group: 2019 = \$21,701,882; 2020 = \$13,332,720; 2021 YTD = \$1,460,807</p> <p>FCAM/MAPC - Totals for REV Fire Group: 2020 = \$6,348,619; 2021 YTD = \$4,385,656</p> <p>HGAC - Totals for REV Fire Group: 2019 = \$59,700,417; 2020 = \$66,851,936; 2021 YTD = \$37,905,966</p> <p>LaMAS (Ferrara Only) - Totals for REV Fire Group - 2019 = \$16,697,950; 2020 = \$39,945,556; 2021 YTD = \$16,584,214</p> <p>NASPO - Totals for REV Fire Group: 2019 = \$7,160,834; 2020 = \$7,357,335; 2021 YTD = \$3,647,860</p> <p>North Carolina Sheriffs - Totals for REV Fire Group - No sales</p> <p>NJ Start - Totals for REV Fire Group: 2019 = \$0.00; 2020 = \$873,240; 2021 YTD = \$5,283,681</p> <p>NPPGOV - Totals for REV Fire Group - No sales</p> <p>Ohio STS - Totals for REV Fire Group - 2019 = \$10,021,008; 2020 = \$4,573,412; 2021 YTD = \$7,485,321</p> <p>PA Costars - Totals for REV Fire Group - 2019 = \$528,482; 2020 = \$4,927,186; 2021 YTD = \$1,620,885</p> <p>Texas Buy Board - Totals for REV Fire Group: 2019 = \$3,831,135; 2020 = Zero Sales; 2021 YTD = No Sales</p>
<p>22</p>	<p>List any GSA contracts or Standing Offers and Supply Arrangements (SOSA) that you hold. What is the annual sales volume for each of these contracts over the past three years?</p>	<p>Not all brands participate in GSA pricing. Ferrara and KME currently have GSA schedules while E-ONE and KME have DLA Troop contracts.</p> <p>For E-ONE: USAF, Georgia, Fire Apparatus, 16 vehicles on 5 separate PO, \$8,635,579 total; US Army, Washington DC, Fire Apparatus, 9 vehicles on 2 separate PO, \$4,160,375 total; US Navy, Washington DC, Fire Apparatus. 2 vehicles on 1 PO, \$1,532,942 total; New Hampshire Training Academy, NH, 1 vehicle, \$845,726.00</p> <p>For KME: US Army National Guard, Military, Washington, DC, (20) Type 3 Wildland vehicles \$359,052 each or \$7,181,055.92 total; US Army, Military, Washington, DC, (7) Water Tankers \$317,153.89 each or \$2,220,077.29 total; USMC, Military, Washington, DC, (5) Water Tankers \$313,626.60 each or \$1,568,183.00 total; US Army National Guard, Military, Washington, DC. (8) Wildland vehicles \$296,264.50 each or \$2,370,116.00 total; USMC, Military, Washington, DC. (4) Wildland vehicles, \$496.260.00 each or \$1,985,040.00 total.</p> <p>For Spartan (Top States); State of TX (pumpers, aerials, platforms) = 43 Units/ \$24,158,085 State of PA (pumpers, tillers, water towers) = 27 Units/\$18,451,964 State of NC (pumpers, aerials, platforms) = 23 Units/\$17,218,037 State of CA (pumpers) = 24 Units/\$14,684,004 State of MI (pumpers, aerials) = \$13,731,604</p>

Table 4: References/Testimonials

Line Item 23. Supply reference information from three customers who are eligible to be Sourcewell participating entities.

Entity Name *	Contact Name *	Phone Number *
City of Albuquerque, NM	Nathaniel Meisner	505-934-8721
County of San Diego, CA	Jimmy Steel	619-851-5722
Fire Department of New York, NY	Mark Aronberg	718-784-6500
City of Asheville Fire Department, NC	Jeremy Knighton	828-552-2071
City of Atlanta Fire Department, GA	Derek Harris	404-597-0418

Table 5: Top Five Government or Education Customers

Line Item 24. Provide a list of your top five government, education, or non-profit customers (entity name is optional), including entity type, the state or province the entity is located in, scope of the project(s), size of transaction(s), and dollar volumes from the past three years.

Entity Name	Entity Type *	State / Province *	Scope of Work *	Size of Transactions *	Dollar Volume Past Three Years *
City of Baton Rouge	Government	Louisiana - LA	Pumpers, Rescues, and Aerials	10 Units	\$7,270,787.00
City of Birmingham	Government	Alabama - AL	Pumper and Aerials	12 Units	\$8,647,814.00
City of San Francisco	Government	California - CA	Pumpers and Aerials	8 Units	\$6,144,801.00
U. S. Army	Government	District of Columbia - DC	Wildlands	20 Units	\$7,181,055.92
U. S. Air Force	Government	Georgia - GA	Misc Vehicles	16 Units	\$8,635,579.00

Table 6: Ability to Sell and Deliver Service

Describe your company's capability to meet the needs of Sourcewell participating entities across the US and Canada, as applicable. Your response should address in detail at least the following areas: locations of your network of sales and service providers, the number of workers (full-time equivalents) involved in each sector, whether these workers are your direct employees (or employees of a third party), and any overlap between the sales and service functions.

Line Item	Question	Response *
25	Sales force.	The REV Fire Group have a confirmed 533 full time sales associates and another 223 part time sales associates. There were however several dealers who did not provide this additional information so the number would be higher. This accounts for all reported brands, dealers, service centers, and Spartan OEMs within the U.S. and Canada.
26	Dealer network or other distribution methods.	<p>The REV Fire Group has 36 dealers representing the E-ONE brand, 20 dealer representing the Ferrara Fire brand, 30 dealers representing the KME Fire brand, 28 dealers representing the Spartan Fire, LLC brand, and 37 OEMs representing the Spartan Chassis brand. Several dealers represent two or more brands but usually specialize in one brand over the other due to their past experience.</p> <p>The 37 OEMs will play a key part in adding Spartan chassis as a new product offering for the REV Group/REV Fire Group. Spartan chassis has never been offered on any other cooperative purchasing contract. These 37 OEMs will be able to work with members to provide chassis pricing for apparatus re-chassis, accident repairs, apparatus upgrades, or body remounts.</p> <p>See the attached dealer list/dealer survey results.</p>
27	Service force.	The REV Fire Group have a confirmed 519 Emergency Vehicle Technicians (EVTs) and another 665 non-EVT technicians. As stated above, not all dealers responded to our survey so the number is actually higher. This accounts for all reported brands, dealers, service centers, and Spartan OEMs within the U.S. and Canada.

28	Describe the ordering process. If orders will be handled by distributors, dealers or others, explain the respective roles of the Proposer and others.	The typical process if for the member to work with the local brand dealer/representative to configure the apparatus to meet their mission, their design requirements, and their budget. The configuration is normally sent for review by the engineering team for approval/changes. Once the member agrees on the configuration and the quoted amount they place the order with the brand dealer/representative. The order is accepted, the member works with the brand and dealer representative to set up a date for a pre-build conference. During the pre-build conference the member can voice concerns or needed changes. The configuration is tweaked to meet any required changes. The updated configuration/price/drawings are presented to the member for his approval. A purchase order is issued by the member to the brand dealer and the dealer submits the order to the brand manufacturer. If there is no dealer involved, then the transaction would be the same except directly with the brand manufacturer/sales representative. Terms are COD when the completed apparatus leaves the manufacturer to be delivered.	*
29	Describe in detail the process and procedure of your customer service program, if applicable. Include your response-time capabilities and commitments, as well as any incentives that help your providers meet your stated service goals or promises.	For service, parts, or customer service needs the member is always encouraged to first contact their local dealer representative. Most dealers and REV Group brands are open during normal daily business hours and respond quickly. Most offer after hour customer support should the member have an issue which needs to be addressed after normal business hours. Each brand and dealer have either toll free customer service numbers or an answer service able to get the correct person to respond.	*
30	Describe your ability and willingness to provide your products and services to Sourcewell participating entities in the United States.	The REV Group/REV Fire Group has a distribution channel eager to service Sourcewell members anywhere in North America. Our 151 dealers/OEMs are ready and willing to work the the members to meet apparatus and apparatus support needs. With out vast array of available products, we are sure we can match our offerings to the members wants and needs.	*
31	Describe your ability and willingness to provide your products and services to Sourcewell participating entities in Canada.	During our last contract with Sourcewell we have eagerly supported the Canadian market by attending Canadian conferences and meeting with procurement professionals at the Ontario/Sourcewell joint conference. We support the CANOE initiative to promote Sourcewell's U S contracts and to adopt them as theirs. Business wise, we will need to adjust our U. S. pricing to reflect differences in currency, provide the additional testing for Canadian compliance, and collect for recycle fees imposed on batteries and tires.	*
32	Identify any geographic areas of the United States or Canada that you will NOT be fully serving through the proposed contract.	While some areas can be very remote, we have always entertained answering the call where there is a need.	*
33	Identify any Sourcewell participating entity sectors (i.e., government, education, not-for-profit) that you will NOT be fully serving through the proposed contract. Explain in detail. For example, does your company have only a regional presence, or do other cooperative purchasing contracts limit your ability to promote another contract?	There are no entity sectors we will not serve and we have nothing limiting our participation in the Sourcewell contract.	*
34	Define any specific contract requirements or restrictions that would apply to our participating entities in Hawaii and Alaska and in US Territories.	We currently serve both areas. One key difference would be delivery cost when shipment of an apparatus is needed. Our estimated driveway cost is to deliver the vehicle to the port. Cost to prepare and ship the vehicle over water or via airlines is at the members expense in addition to our normal driveway expense.	*

Table 7: Marketing Plan

Line Item	Question	Response *
35	Describe your marketing strategy for promoting this contract opportunity. Upload representative samples of your marketing materials (if applicable) in the document upload section of your response.	<p>The REV Fire Group recently hired Natalie Childress as Senior Director of Marketing. She will partner with REV Fire Group's Vice President of Sales, Mike Virnig, and divisional teams to evolve brand strategy and consumer experience for the group's fire truck brands. Childress has more than nine years of marketing and brand experience, including five years of marketing and business development leadership experience.</p> <p>She most recently served as the Business Strategy Manager for Mastercraft Boat Company, driving global brand building and strategy. Prior to, Childress held progressive roles with a focus on cross-functional branding, product marketing and owners' experience within Sea Ray, part of Brunswick Corporation. She was recognized as a 40 Under 40 Marine Industry Leader this year by Boating Industry.</p> <p>She will be instrumental in leading us during our transition from a single brand within the Sourcewell contract to a multi-brand contractor. It will be important Sourcewell members understand REV Fire Groups capabilities and how each brand has responded as part of the RFP. Our goal would be for each brand to be linked from the Sourcewell awarded contract so members can view each brands product and service offerings versus only seeing an overview of all the brands as one.</p>
36	Describe your use of technology and digital data (e.g., social media, metadata usage) to enhance marketing effectiveness.	Social media and digital advertising will be key to communicating to Sourcewell members our capabilities, our products, our services, and our brands.
37	In your view, what is Sourcewell's role in promoting contracts arising out of this RFP? How will you integrate a Sourcewell-awarded contract into your sales process?	It is important Sourcewell and the REV Fire Group brands work jointly to promote our partnership to serve the needs of the member base, and to recruit new members as we go forward. We currently promote Sourcewell and encourage our dealer partners to actively discuss all the opportunities for providing products and services to their organization under a single contract umbrella.
38	Are your products or services available through an e-procurement ordering process? If so, describe your e-procurement system and how governmental and educational customers have used it.	At this time only our parts procurement system provides e-procurement. The complexity of custom designing a fire apparatus is a programmers nightmare as the number of engineering rules has to change as each option is chosen. The programming must look for multiple options being selected for the same space, components hitting each other due to their movement, and another set of complicated rules to govern operation safety.

Table 8: Value-Added Attributes

Line Item	Question	Response *
39	Describe any product, equipment, maintenance, or operator training programs that you offer to Sourcewell participating entities. Include details, such as whether training is standard or optional, who provides training, and any costs that apply.	<p>As part the REV Group/REV Fire Group proposal, we are offering the following solutions in addition to our fire apparatus:</p> <p>Leasing - with REV Finance, other third party leasing companies within our industry, local banks or other third party financial institutions the member wishes to pursue.</p> <p>Parts contracts.</p> <p>Service contracts.</p> <p>Accident repairs.</p> <p>Apparatus refurb/upgrades.</p> <p>Vehicle trade-ins. This could be thru REV, the local dealer, or a third party vendor willing to purchase the vehicle.</p> <p>Maintenance contracts.</p> <p>Brand specific extended warranties.</p> <p>Vendor specific extended warranties.</p> <p>Training located at the brand's facilities or remotely offered at a location designated by the member. Training can be based on maintenance of the vehicle, operation of the vehicle, or as a refresher course where maintenance, safety, and operation are covered. Three days of training is standard and required to be performed by factory trainers on all aerials, industrial pumpers, and ARFF vehicles.</p>

40	Describe any technological advances that your proposed products or services offer.	<p>As part of the REV Group our other divisions are making great strides in electric vehicle (EV). For example:</p> <p>ENC® DEBUTS THE AXESS BATTERY ELECTRIC BUS (BEB) AT APTA EXPO THE FIRST EV BUS THAT IS ZERO EMISSIONS AND ZERO CORROSION. October 25, 2021 Link: https://www.revgroup.com/blog-single/enc-debuts-the-axess-battery-electric-bus-beb-at-apta-expo-the-first-ev-bus-that-is-zero-emissions-and-zero-corrosion</p> <p>REV GROUP'S COLLINS BUS ENTERS MULTIYEAR AGREEMENT WITH LIGHTNING EMOTORS FOR ELECTRIC SCHOOL BUSES. August 31st, 2021 Link: https://www.revgroup.com/blog-single/rev-groups-collins-bus-enters-multiyear-agreement-with-lightning-emotors-for-electric-school-buses</p> <p>CAPACITY TRUCKS® INTRODUCES FIRST NORTH AMERICAN HYDROGEN FUEL CELL ELECTRIC HYBRID TRUCK BUILT FROM THE GROUND UP. August 26th, 2021 Link:https://www.revgroup.com/blog-single/capacity-trucks-introduces-first-north-american-hydrogen-fuel-cell-electric-hybrid-truck-built-from-the-ground-up</p> <p>REV FIRE GROUP® TO SHOWCASE LATEST IN FIRE APPARATUS AND UNVEIL WORLD OF INNOVATION AND PROTECTION AT FDIC 2021. August 5th, 2021 Link: https://www.revgroup.com/blog-single/rev-fire-group-to-showcase-latest-in-fire-apparatus-and-unveil-world-of-innovation-and-protection-at-fdic-2021</p> <p>This showcase included the following:</p> <ol style="list-style-type: none"> 1. Smart Reach™ Multi-Stance™ System: Through augmented reality, attendees can experience firsthand this patented new Smeal ladder and outrigger control system that offers 360-degree, no dead-zone functionality on aerials that can be adapted to the scene while maintaining full reach. The Smart Reach control console provides real-time data, and its electric and hydraulic aerial controls offer the ultimate in smooth operation. It also offers Advance Rung Lighting, a series of RGB LED light strips that can have customized patterns running the length of the ladder. 2. Smart Flo™: This integrated pressure governor system for fire apparatus allows control of both water flow and foam from one location. It features a one-button pump shift for ease of operation, automatic pump protection and a camera display of the officer's side, offering firefighters total control at any fire scene. 3. ECO IDLE-TEC™: This idle reduction system specifically designed for fire apparatus shuts off the main engine during EMS and rescue calls, eliminating loud diesel engine noise and exhaust while maintaining power for lighting, air conditioning and more. This reduces operating costs, protects the environment, and improves driver safety and comfort. 4. Active Air Purification System: Designed with advanced Photohydroionization® (PHI Cell) and UV technology, these units kill 99 percent of pathogens, including the virus which causes COVID-19, in the air and on surfaces delivering better air quality and a safer cab environment for your crew. <p>This technology has been recently expanded with the introduction of E-ONE's newest product, the industries first all electric fire truck. Press release link: https://www.revgroup.com/blog-single/rev-fire-group-receives-order-from-the-mesa-fire-and-medical-department-for-an-eone-vector-north-americas-first-fully-electric-fire-truck-</p>
41	Describe any "green" initiatives that relate to your company or to your products or services, and include a list of the certifying agency for each.	<p>The REV Group is a leader in providing new products and technology which contribute to the green footprint needed to protect our environment. We promote recycling of all that is possible. REV recently released an occupant air purification and filtration systems to help reduce risk to toxins and viruses. This can be retrofitted to any vehicle manufactured. It removes 99% of impurities and treats the air for bacteria such as Covid 19.</p>
42	Identify any third-party issued eco-labels, ratings or certifications that your company has received for the equipment or products included in your Proposal related to energy efficiency or conservation, life-cycle design (cradle-to-cradle), or other green/sustainability factors.	<p>We do not have any 3rd party issued eco-labels. We do not see much of this in our industry even though you may provide the latest in technology such as our all electric fire truck.</p>
43	Describe any Women or Minority Business Entity (WMBE), Small Business Entity (SBE), or veteran owned business certifications that your company or hub partners have obtained. Upload documentation of certification (as applicable) in the document upload section of your response.	<p>We do not tract this. We do however look to do business with those companies which provide value for our customers. REV Group rewards women for doing a great job by promoting them as managers. REV Group honors our vets by having yearly luncheons and acknowledging their service to our country.</p>

44	What unique attributes does your company, your products, or your services offer to Sourcewell participating entities? What makes your proposed solutions unique in your industry as it applies to Sourcewell participating entities?	I think we have the best cradle to grave offering for your members. With the REV Group/REV Fire Group providing options from 7 fire apparatus brands, we are sure your members can find what they need. As custom builders we pride ourselves in exceeding the members expectations. Our total solutions include parts contracts, service contracts, training, accident repairs, apparatus refurb, upgrades, and remount. The addition of adding the Spartan chassis separately from a complete apparatus should provide your members one additional solution if they are looking to extend the life expectancy of their current vehicles.	*
----	--	--	---

Table 9: Warranty

Describe in detail your manufacturer warranty program, including conditions and requirements to qualify, claims procedure, and overall structure. You may upload representative samples of your warranty materials (if applicable) in the document upload section of your response in addition to responding to the questions below.

Line Item	Question	Response *	
45	Do your warranties cover all products, parts, and labor?	Yes with limited time periods	*
46	Do your warranties impose usage restrictions or other limitations that adversely affect coverage?	Since warranty is a legal document with legal responsibilities, we do provide specifics related to lack of maintenance, abuse, neglect, misuse, and/or failure to notify. In some cases there may be certain inspections which must be performed to keep the warranty in force.	*
47	Do your warranties cover the expense of technicians' travel time and mileage to perform warranty repairs?	Yes	*
48	Are there any geographic regions of the United States or Canada (as applicable) for which you cannot provide a certified technician to perform warranty repairs? How will Sourcewell participating entities in these regions be provided service for warranty repair?	Typically the selling dealer will service their sales territories. Each brand does support the distribution channel with factory based technicians. In cases where a problem is hard to remedy, both the dealer and the manufacture will team up to resolve the issue.	*
49	Will you cover warranty service for items made by other manufacturers that are part of your proposal, or are these warranties issues typically passed on to the original equipment manufacturer?	It depends on the severity and the approval extended by the supplier. We prefer to be a one stop shop for the member if he has a problem. In many cases the supplier requires the failure to be repaired by their technicians at their location.	*
50	What are your proposed exchange and return programs and policies?	Please see the attached document for this section.	*
51	Describe any service contract options for the items included in your proposal.	Service contract will normally be between the member and the selling dealer. In some cases service contracts can be thru the manufacturer. This scenario could be an option where there is a highly technical component of the apparatus the dealer may not have the expertise to correct. We offer extended warranties, drive train warranties, vendor component extended warranties, and third party extended warranties.	*

Table 10: Payment Terms and Financing Options

Line Item	Question	Response *	
52	Describe your payment terms and accepted payment methods.	Payment terms are COD at the time the apparatus leaves the plant for delivery to the customer. The selling dealer however may provide additional times based on the contract with the member. This could range from COD to 30+ days.	*
53	Describe any leasing or financing options available for use by educational or governmental entities.	The REV Group has our own internal finance company. We also use third part providers when asked to provide leasing quotes. We also recommend the member check with local lending institutions to make sure they are taking advantage of all resources to obtain the most competitive rates.	*
54	Describe any standard transaction documents that you propose to use in connection with an awarded contract (order forms, terms and conditions, service level agreements, etc.). Upload a sample of each (as applicable) in the document upload section of your response.	All brands would provide a quote to the member based on their custom configured apparatus. There would be contract between the selling dealer/manufacture and the member. Worksheets are typically used to calculate the agreed discount and the customer should receive a customer summary sheet if requested.	*
55	Do you accept the P-card procurement and payment process? If so, is there any additional cost to Sourcewell participating entities for using this process?	Most of our brands do accept P cards with no additional cost involved. We do however have some brands who do not.	*

Table 11: Pricing and Delivery

Provide detailed pricing information in the questions that follow below. Keep in mind that reasonable price and product adjustments can be made during the term of an awarded Contract as described in the RFP, the template Contract, and the Sourcewell Price and Product Change Request Form.

Line Item	Question	Response *
56	Describe your pricing model (e.g., line-item discounts or product-category discounts). Provide detailed pricing data (including standard or list pricing and the Sourcewell discounted price) on all of the items that you want Sourcewell to consider as part of your RFP response. If applicable, provide a SKU for each item in your proposal. Upload your pricing materials (if applicable) in the document upload section of your response.	Our pricing model discounts are based off MSRP minus a percentage or a flat discount on certain market specific products where discount are not normally offered. The pricing includes up to \$5,000 for driveway, PDI, and dealer delivery and training. Taxes, trips, pre-pay discounts, multiple quantity discounts, and trade-ins are not included in these prices but will change the price to the member if part of the order.
57	Quantify the pricing discount represented by the pricing proposal in this response. For example, if the pricing in your response represents a percentage discount from MSRP or list, state the percentage or percentage range.	Pricing discounts range from 3% to 20% depending on the brand and the product offered. In some cases a flat fee discount is offered which ranges from \$5,000 to \$15,000.
58	Describe any quantity or volume discounts or rebate programs that you offer.	Depending on the model of the apparatus and the overall deal, multiple unit discounts could be offered starting at around 1% more per unit. This would be affected by the mix and the quantity of the apparatus purchased.
59	Propose a method of facilitating "sourced" products or related services, which may be referred to as "open market" items or "nonstandard options". For example, you may supply such items "at cost" or "at cost plus a percentage," or you may supply a quote for each such request.	If the sourced items are items supplied by the brand, these would be treated as a part of the apparatus and the same discount would apply based on the model of the apparatus. For items purchased as loose equipment or customer requested items, these would be provide at cost with a 30% or less markup.
60	Identify any element of the total cost of acquisition that is NOT included in the pricing submitted with your response. This includes all additional charges associated with a purchase that are not directly identified as freight or shipping charges. For example, list costs for items like pre-delivery inspection, installation, set up, mandatory training, or initial inspection. Identify any parties that impose such costs and their relationship to the Proposer.	Driveway up to \$5,000 is included and will be adjusted up or down based on the actual cost plus a \$200 admin fee. For shipments where the apparatus has to be shipped or flown to it's destination, these additional cost over and above getting the vehicle to the port would be the responsibility of the member. Pre-build and inspection trips are not included. Taxes are not included. NFPA requires we provide 3 days of training on all aerials, industrial pumpers, and ARFFs which is include in the quote. All other training is provided by the selling dealer.
61	If freight, delivery, or shipping is an additional cost to the Sourcewell participating entity, describe in detail the complete freight, shipping, and delivery program.	As stated above, we have included up to \$5,000 allowance for delivery on each unit. If the actual price to deliver is less, the member will receive a credit. If the actual price is more, the member will be responsible for the added expense. This is also true for PDI and Dealer Delivery and training. We have included values within the quote for different models but the member could be billed more or provided a credit depending on the actual cost.
62	Specifically describe freight, shipping, and delivery terms or programs available for Alaska, Hawaii, Canada, or any offshore delivery.	As stated above, our standard quote includes delivering the apparatus to the port. Cost associated with completing the delivery is on a case by case basis depending on the additional requirements set by the member. We would provide a quote for their approval.
63	Describe any unique distribution and/or delivery methods or options offered in your proposal.	Nothing unique. We provide delivery of the vehicle as requested by the end user. If the apparatus is being shipped on a boat, the member might request the apparatus be wrapped and/or loaded in a container. The expense for these items would be based on a case by case basis and would differ based on the type vehicle, weight, size, and market price at the time of the shipment.

Table 12: Pricing Offered

Line Item	The Pricing Offered in this Proposal is: *	Comments
64	b. the same as the Proposer typically offers to GPOs, cooperative procurement organizations, or state purchasing departments.	While we must be competitive on all cooperative procurement contracts, ultimately the market and the competition drive our pricing to your members. The key is which contract you use, its simplicity, and the support from the management team with the respective contract. Sourcewell is our go to contract.

Table 13: Audit and Administrative Fee

Line Item	Question	Response *
65	Specifically describe any self-audit process or program that you plan to employ to verify compliance with your proposed Contract with Sourcewell. This process includes ensuring that Sourcewell participating entities obtain the proper pricing, that the Vendor reports all sales under the Contract each quarter, and that the Vendor remits the proper administrative fee to Sourcewell. Provide sufficient detail to support your ability to report quarterly sales to Sourcewell as described in the Contract template.	We use a self audit spreadsheet which gives the selling dealer a go/no go visual indicator of their compliance to the contract. The goal of the spreadsheet was to communicate how the numbers were calculated and to show the customer we met or exceeded the contracted discounts within the RFP. *
66	If you are awarded a contract, provide a few examples of internal metrics that will be tracked to measure whether you are having success with the contract.	We track sales proposed as Sourcewell contracted business versus actual booked business. Currently this information can be sorted by quote number, truck number, customer, state/province, apparatus model, date sold, delivered/not delivered, and/or selling dealer. *
67	Identify a proposed administrative fee that you will pay to Sourcewell for facilitating, managing, and promoting the Sourcewell Contract in the event that you are awarded a Contract. This fee is typically calculated as a percentage of Vendor's sales under the Contract or as a per-unit fee; it is not a line-item addition to the Member's cost of goods. (See the RFP and template Contract for additional details.)	.75% of the contracted amount with admin fee ceilings based on the following: All commercial chassis products (except aerials) = \$1500.00 max All custom chassis products (except aerials) = \$1750.00 max All aerials = \$2000.00 max All apparatus accident repairs/re-chassis/body remount, apparatus upgrades, and Spartan chassis quotes = \$1750.00 max Combinations of multiple apparatus purchased via the same purchase order = \$2000.00 max. * The above admin fees were chosen to compete with the many other cooperative contracts the member would have at their disposal. If you use a straight percentage of 1% the admin fee will be too high and the member will move to the more competitive contract. Thus, the purchase will not be booked thru Sourcewell. Parts and service programs/contracts as per the following:

Table 14A: Depth and Breadth of Offered Equipment Products and Services

Line Item	Question	Response *
68	Provide a detailed description of the equipment, products, and services that you are offering in your proposal.	<p>As it relates to fire apparatus: The REV Group and its multiple fire apparatus brands (REV Fire Group) offer Sourcewell members a wide variety of models. These include brush trucks, urban interface units, crew haulers, air and light units, light rescues, medium rescues, heavy rescues, combo rescues, walk-in/walk around rescues, command vehicles, hazmat vehicles, pumpers, rescue pumpers, wet side tankers, dry side tankers, vacuum tankers, elliptical tankers, aerial booms, aerial ladders, aerial platforms, ARFF units, ARFF foam testing units, and Rhino turrets. In addition to apparatus, we offer service/maintenance, parts, training, refurbishment/upgrades, accident repair services, and any other new/product or service agreed upon by the member and fits within the scope of the RFP.</p> <p>As it relates to Spartan Chassis - these chassis' are offered by many fire apparatus manufacturers which are not part of the REV GROUP/REV Fire Group. In most cases they are competitors of the REV Fire Group. That said, within the scope of the RFP, we wanted to provide our dealer partners and Spartan Chassis' OEMs the option to offer chassis upgrades, re-chassis options, wreck repairs, and body remounts on a new Spartan chassis via the Sourcewell contract, thus eliminate the requirement of going out to bid.. The agreed discount and admin fee would only be based on the chassis quote. All other expenses, labor, parts, and loose equipment would be listed separately from the chassis line item quote, must be approved by the Sourcewell member, and fit within the scope of the RFP.</p>
69	Within this RFP category there may be subcategories of solutions. List subcategory titles that best describe your products and services.	<p>For fire apparatus - we offer leasing, trade-ins, pre-pay discounts, and multiple unit discounts. For leasing this would be handled thru REV Leasing, one of many third party leasing companies within the industry, or through local institutions agreed upon by the member and fits within the scope of the RFP.</p> <p>For service/parts purchases - these would brand specific new parts, vendor supplied parts, brand/dealer supplied parts/loose equipment, brand/dealer supplied PPE/fire fighting support equipment, services (other-TBD) where the need expressed by the member fits within the scope of the RFP, and any volume discounts which may apply.</p> <p>For Product Life Cycle Extension Services - these would include wreck repairs, apparatus upgrades, apparatus refurb, dealer/third party annual aerial inspection/certification, dealer/third party annual pump testing, and dealer/third party contracted services (other-TBD) where the need expressed by the member fits within the scope of the RFP.</p> <p>For Extended Warranties - these would included warranties offered specifically by the brand (base warranty extensions and/or bumper to bumper warranties, third party drivetrain warranties, vendor supplied extended warranties, or additional warranties requested by the member and falls within the scope of the RFP.</p> <p>Contract Services - these would be brand provided service contracts, training offered by each brand, service contracts negotiated with our dealer partners, parts contracts negotiated with our dealer partners, training services negotiated with our dealer partners, or any added contract services agreed upon by the member and fits within the scope of the RFP.</p>

Table 14B: Depth and Breadth of Offered Equipment Products and Services

Indicate below if the listed types or classes of equipment, products, and services are offered within your proposal. Provide additional comments in the text box provided, as necessary.

Line Item	Category or Type	Offered *	Comments	
70	Firefighting apparatus and service vehicles, of all types, such as: pumper/engine, initial attack, mobile water supply, aerial, quint, special service, mobile foam, command and communications, and purpose-built firefighting or rescue trailers	<input checked="" type="radio"/> Yes <input type="radio"/> No	Do not offer rescue trailers.	*
71	Wildland fire apparatus, of all types, such as: fire suppression equipment, mobile water supply, and crew carriers	<input checked="" type="radio"/> Yes <input type="radio"/> No	All of the mentioned including brush trucks and initial attack vehicles.	*
72	Aircraft rescue and firefighting vehicles	<input checked="" type="radio"/> Yes <input type="radio"/> No	Also providing a mobile foam tester.	*
73	Purpose-built chassis and vehicle components for firefighting apparatus and fire service vehicles	<input checked="" type="radio"/> Yes <input type="radio"/> No	Offering brand specific chassis for wreck repair, refurb, and chassis upgrades. Also offering Spartan custom built chassis as additional option for re-chassis solutions.	*
74	Equipment, options, accessories, and supplies complementary or incidental to the purchase of a turnkey or complete unit of the types described in Lines 70-72 above	<input checked="" type="radio"/> Yes <input type="radio"/> No	Offered thru the manufacturing brand or selling dealer.	
75	Services related to the offering of the solutions described in Lines 70-74, including installation, customization, remount, refurbishment, inspection, repair, maintenance, training, and support	<input checked="" type="radio"/> Yes <input type="radio"/> No	All of the items are offered. Also offering accident repairs.	*

Table 15: Industry Specific Questions

Line Item	Question	Response *
76	Describe available service and repair options for the equipment and products offered in your proposal.	A list of dealers and service locations is provided. Depending on the dealer's capabilities added services may be available. This could include pump testing, aerial testing, air pack testing/repair, upfitting, and/or wreck repair.
77	Describe available remount or refurbishing services included within your proposal, the pricing method for such services, and any related order processes.	A list of dealers and service locations is provided. Depending on the dealer's capabilities these added services may be available. If not available at the dealer location the manufacturing brand could provide labor and material quotes based on the requested repairs.
78	Describe your compliance with US standards for the equipment and products offered in your proposal, including applicable federal and state requirements.	<p>Most of our manufacturing facilities are ISO9001 Quality Certified</p> <p>All vehicles must be built to NFPA 1901 or 1906. We provide the member a Letter of Compliance and any item requested not meeting these standards is listed as non-compliant whereas the member and/or dealer must sign and dictate who is responsible for correcting the deficiency prior to putting vehicle in service. See attachments.</p> <p>All ARFFs must meet NFPA 414 and NFPA 412 Standards.</p> <p>Some facilities undergo and pass the UL Inspection Program (VIP) for NFPA 1901. See attachments.</p> <p>Must meet FMVSS—Federal Motor Vehicle Safety Standards</p> <p>All custom cabs must meet the Economic Commission for Europe (ECE) R-29 cab crash testing.</p> <p>Society of Automotive Engineers (SAE) Standards where specified.</p> <p>Underwriters Laboratories (UL & ULC)</p> <p>Federal Aviation Administration (FAA) AC 150/5220-10 for ARFF</p>
79	Describe your compliance with Canadian standards for the equipment and products offered in your proposal, including applicable federal and provincial requirements.	<p>The same as U.S. built units but with the following additional testing requirements:</p> <p>Must meet ULC S515 for all apparatus sold in Canada.</p> <p>Must meet CMVSS—Canadian Motor Vehicle Safety Standards</p> <p>International Civil Aviation Organization (ICAO)</p> <p>Units delivered in Canada must also pass a required motor vehicle test prior to unit being put into service.</p>

Table 16: Exceptions to Terms, Conditions, or Specifications Form

Line Item 80. NOTICE: To identify any exception, or to request any modification, to the Sourcwell template Contract terms, conditions, or specifications, a Proposer must submit the exception or requested modification on the **Exceptions to Terms, Conditions, or Specifications Form** immediately below. The contract section, the specific text addressed by the exception or requested modification, and the proposed modification must be identified in detail. Proposer's exceptions and proposed modifications are subject to review and approval of Sourcwell and will not automatically be included in the contract.

Contract Section	Term, Condition, or Specification	Exception or Proposed Modification

Documents

Ensure your submission document(s) conforms to the following:

1. Documents in PDF format are preferred. Documents in Word, Excel, or compatible formats may also be provided.
2. Documents should NOT have a security password, as Sourcewell may not be able to open the file. It is your sole responsibility to ensure that the uploaded document(s) are not either defective, corrupted or blank and that the documents can be opened and viewed by Sourcewell.
3. Sourcewell may reject any response where any document(s) cannot be opened and viewed by Sourcewell.
4. If you need to upload more than one (1) document for a single item, you should combine the documents into one zipped file. If the zipped file contains more than one (1) document, ensure each document is named, in relation to the submission format item responding to. For example, if responding to the Marketing Plan category save the document as "Marketing Plan."
 - [Pricing](#) - REV Group_ E-ONE Apparatus Models_Pricing_Discounts Updated.pdf - Tuesday November 30, 2021 15:44:05
 - [Financial Strength and Stability](#) - REV GROUP (REV Fire Group) Financial Strength and Stability.pdf - Tuesday November 30, 2021 15:15:51
 - Marketing Plan/Samples (optional)
 - [WMBE/MBE/SBE or Related Certificates](#) - REV Fire Group Certifications.pdf - Tuesday November 30, 2021 15:47:00
 - [Warranty Information](#) - REV Fire Group Warranties.pdf - Tuesday November 30, 2021 16:05:38
 - [Standard Transaction Document Samples](#) - 20211110 Q113020 Mesa AZ, H & E (AZ) Custom Summary Report - Amended.pdf - Tuesday November 30, 2021 16:20:31
 - [Upload Additional Document](#) - REV Group Misc Files.pdf - Tuesday November 30, 2021 16:18:34

Addenda, Terms and Conditions

PROPOSER AFFIDAVIT AND ASSURANCE OF COMPLIANCE

I certify that I am the authorized representative of the Proposer submitting the foregoing Proposal with the legal authority to bind the Proposer to this Affidavit and Assurance of Compliance:

1. The Proposer is submitting this Proposal under its full and complete legal name, and the Proposer legally exists in good standing in the jurisdiction of its residence.
2. The Proposer warrants that the information provided in this Proposal is true, correct, and reliable for purposes of evaluation for contract award.
3. The Proposer, including any person assisting with the creation of this Proposal, has arrived at this Proposal independently and the Proposal has been created without colluding with any other person, company, or parties that have or will submit a proposal under this solicitation; and the Proposal has in all respects been created fairly without any fraud or dishonesty. The Proposer has not directly or indirectly entered into any agreement or arrangement with any person or business in an effort to influence any part of this solicitation or operations of a resulting contract; and the Proposer has not taken any action in restraint of free trade or competitiveness in connection with this solicitation. Additionally, if Proposer has worked with a consultant on the Proposal, the consultant (an individual or a company) has not assisted any other entity that has submitted or will submit a proposal for this solicitation.
4. To the best of its knowledge and belief, and except as otherwise disclosed in the Proposal, there are no relevant facts or circumstances which could give rise to an organizational conflict of interest. An organizational conflict of interest exists when a vendor has an unfair competitive advantage or the vendor's objectivity in performing the contract is, or might be, impaired.
5. The contents of the Proposal have not been communicated by the Proposer or its employees or agents to any person not an employee or legally authorized agent of the Proposer and will not be communicated to any such persons prior to Due Date of this solicitation.
6. If awarded a contract, the Proposer will provide to Sourcewell Participating Entities the equipment, products, and services in accordance with the terms, conditions, and scope of a resulting contract.
7. The Proposer possesses, or will possess before delivering any equipment, products, or services, all applicable licenses or certifications necessary to deliver such equipment, products, or services under any resulting contract.
8. The Proposer agrees to deliver equipment, products, and services through valid contracts, purchase orders, or means that are acceptable to Sourcewell Members. Unless otherwise agreed to, the Proposer must provide only new and first-quality products and related services to Sourcewell Members under an awarded Contract.
9. The Proposer will comply with all applicable provisions of federal, state, and local laws, regulations, rules, and orders.
10. The Proposer understands that Sourcewell will reject RFP proposals that are marked "confidential" (or "nonpublic," etc.), either substantially or in their entirety. Under Minnesota Statutes Section 13.591, subdivision 4, all proposals are considered nonpublic data until the evaluation is complete and a Contract is awarded. At that point, proposals become public data. Minnesota Statutes Section 13.37 permits only certain narrowly defined data to be considered a "trade secret," and thus nonpublic data under Minnesota's Data Practices Act.
11. Proposer its employees, agents, and subcontractors are not:
 1. Included on the "Specially Designated Nationals and Blocked Persons" list maintained by the Office of Foreign Assets Control of the United States Department of the Treasury found at: <https://www.treasury.gov/ofac/downloads/sdnlist.pdf>;
 2. Included on the government-wide exclusions lists in the United States System for Award Management found at: <https://sam.gov/SAM/>; or
 3. Presently debarred, suspended, proposed for debarment, declared ineligible, or voluntarily excluded from programs operated

by the State of Minnesota; the United States federal government or the Canadian government, as applicable; or any Participating Entity. Vendor certifies and warrants that neither it nor its principals have been convicted of a criminal offense related to the subject matter of this solicitation.

By checking this box I acknowledge that I am bound by the terms of the Proposer's Affidavit, have the legal authority to submit this Proposal on behalf of the Proposer, and that this electronic acknowledgment has the same legal effect, validity, and enforceability as if I had hand signed the Proposal. This signature will not be denied such legal effect, validity, or enforceability solely because an electronic signature or electronic record was used in its formation. - Fred Cureton, National Contract Manager, REV Group, INC.

The Proposer declares that there is an actual or potential Conflict of Interest relating to the preparation of its submission, and/or the Proposer foresees an actual or potential Conflict of Interest in performing the contractual obligations contemplated in the bid.

Yes No

The Bidder acknowledges and agrees that the addendum/addenda below form part of the Bid Document.

Check the box in the column "I have reviewed this addendum" below to acknowledge each of the addenda.

File Name	I have reviewed the below addendum and attachments (if applicable)	Pages
Addendum_4_Fire_Apparatus_RFP_113021 Sat November 20 2021 12:53 PM	<input checked="" type="checkbox"/>	5
Addendum_3_Fire_Apparatus_RFP_113021 Thu November 11 2021 02:09 PM	<input checked="" type="checkbox"/>	1
Addendum_2_Fire_Apparatus_RFP_113021 Fri October 29 2021 09:20 AM	<input checked="" type="checkbox"/>	1
Addendum_1_Fire_Apparatus_RFP_113021 Fri October 29 2021 09:20 AM	<input checked="" type="checkbox"/>	1



City of Galveston

ISLAND TRANSIT STAFF REPORT

Date February 18, 2025

To: City Manager
Mayor and City Council Members

From: David Smith, Executive Director
Fleet, Mass Transit and Special Events

James Oliver
Island Transit General Manager

Project location: N/A

Project: FTA Requirement of Legal Opinion
Resolution for Eligibility

Request: Consider for the approval of a prerequisite to be a recipient of FTA funding that is demonstrating the legal capacity to carry out the project(s) included in federal assistance awards and authorize the City Managers' staff to execute the subject item upon final approval by the City Attorney.

Prior Council Action No prior Council action.

Background

- A. The Federal Transit Administration (FTA) provides federal assistance awards for different project(s) in public transportation.
- B. A prerequisite to federal assistance awards is the demonstrated legal capacity to carry out the project(s).
- C. A recipient must be eligible and authorized under state or local law to request, receive and spend FTA funds to administer FTA-assisted projects.
- D. FTA has requested from each recipient the following:
 - **Opinion of Counsel:** Each recipient must be legally empowered to carry out the activities specified in the award.





City of Galveston

ISLAND TRANSIT STAFF REPORT

- **Authorizing Resolution:** Each recipient organization must have a resolution or equivalent, from the recipient's Board of Directors or equivalent Authorizing Official, to be responsible for applying for assistance legally committing the applicant or recipient to compliance with terms of an award.

Fiscal Impact Report

Approval of this item follows FTA requirements and allows Galveston to apply for and receive grant funding.

Alternatives

A. Approve.

1. Cost - None
2. Timing - As soon as possible.
3. Departmental Improvements - Will allow Island Transit to apply for and receive federal awards for public transportation.

B. Do not approve.

1. Cost - Loss of grant funding.
2. Timing - N/A
3. Departmental Improvements - Island Transit will be found in non-compliance and will lose eligibility to apply for and receive federal grant funding.

Staff Recommendation

Concur in *Alternative A*; *approve* a prerequisite to be a recipient of FTA funding that is demonstrating the legal capacity to carry out the project(s) included in federal assistance awards and authorize the City Managers' staff to execute the subject item upon final approval by the City Attorney.

Attachments





City of Galveston

OFFICE OF THE CITY ATTORNEY
PO Box 779 | Galveston, TX 77553-0779
legal@galvestontx.gov | 409-797-3530

LEGAL OPINION

DATE: January 31, 2025

TO: City Council
City Manager, Brian Maxwell

FROM: Donna Fairweather, Sr. Assistant City Attorney
CONCUR: Donald Glywasky, City Attorney

Name of Applicant: City of Galveston
Address: 823 Rosenberg
P.O. Box 779
Galveston, Texas 77553

RE: Federal Transit Administration – TrAMS, FTA’s grant management system

To Members of City Council and City Manager, Brian Maxwell,

To be a recipient of Federal Transit Administration (FTA) funding, the City is required to demonstrate its legal capacity to carry out the projects included in federal assistance awards. This communication will serve as the requisite Opinion of Counsel, to be filed with the FTA, United States Department of Transportation, in connection with the application of the City of Galveston for federal transportation assistance as authorized by 49 U.S.C., Chapter 53; title 23, United States Code; and other federal statutes, authorizing activities administered by the FTA.

The City of Galveston is the Designated Recipient, as defined by 49 U.S.C. 5307(a)(2), to apply for and receive Urbanized Area Formula Program assistance. 49 U.S.C. 5307 makes federal resources available to assist in financing transportation operations, maintenance, and capital projects through Urbanized Area Formula Funding grants.

Citations to laws, regulations, etc. establishing the legal authority of the City of Galveston to carry out transportation projects for which federal assistance is sought is set forth as follows. In accordance with the requirements of 49 U.S.C. 5307(a)(2), the City of Galveston qualifies as a small, urbanized area, having a population of a little more than 50,000, and less than 200,000. The

City of Galveston is authorized to provide and carry out public transportation and transportation projects for which the federal assistance is sought through the grant funding program.

The authority of the City of Galveston to provide funds for the local share of the project is set forth by adoption of the city's annual budget and the processes thereof. The City of Galveston adopted its Fiscal Year 2025 (FY 2025), budget on September 19, 2024, via Ordinance No. 24-058. The Ordinance adopted the city's annual governmental and Proprietary Funds budget, and its fiscal year Capital Funds budget. The approximate funding amount budgeted for FY 2025 is \$975,000.00 in General Funds.

Federal Formula Fund Awards available for FY 2025 are approximately 1.9 to 2 million dollars. The City of Galveston is a Direct Recipient of federal formula funding and has received a split letter award, submitted to the FTA, by the Department of Transportation (DOT).

I have reviewed the pertinent federal, state, and local laws, and I have concluded that there is no legal impediment to the City of Galveston filing an application for the project(s) for which the City of Galveston seeks assistance. Furthermore, as a result of my examination, I find that there is no pending or threatened litigation or other action which might in any way adversely affect the proposed project(s) or the capability of the City of Galveston to carry out the project(s).

Respectfully submitted,

Donna M. Fairweather,
Sr. Assistant City Attorney

Cc'd:
City Secretary, Janelle Williams
City Finance Director, Csilla Ludanyi
James Oliver, General Manager of Public Transportation

Enclosure: City of Galveston Resolution No. 25 - ____

RESOLUTION NO. 25 - ____

A RESOLUTION OF THE CITY COUNCIL OF THE CITY OF GALVESTON, TEXAS, AUTHORIZING THE CITY MANAGER OR DESIGNEE, TO EXECUTE THOSE DOCUMENTS NECESSARY AND RELATED TO THE APPLICATION FOR AND RECEIPT OF FTA FUNDING; ACCEPTING THE LEGAL OPINION OF THE CITY ATTORNEY AS TO THE CITY'S ELIGIBILITY AND AUTHORITY UNDER STATE OR LOCAL LAW TO REQUEST, RECEIVE AND SPEND FEDERAL TRANSIT AUTHORITY (FTA) FUNDS, AND ITS CAPACITY TO CARRY OUT FTA FUNDED PROGRAMS AND PROJECTS; AUTHORIZING THE CITY SECRETARY TO SEND A CERTIFIED COPY OF THIS RESOLUTION AND ACCOMPANYING LEGAL OPINION IN SATISFACTION OF THE REQUIREMENTS OF THE FTA'S "TRANSPORTATION AWARD MANAGEMENT SYSTEM" (TRAMS), PROGRAM; PROVIDING FOR FINDINGS OF FACT AND PROVIDING FOR AN EFFECTIVE DATE.

WHEREAS, the Federal Transit Authority (FTA) requires recipients of FTA funding to demonstrate their legal capacity to carry out project(s) included in their federal assistance awards. Recipients must be eligible and authorized under state or local law to request, receive, and spend FTA funds to administer FTA assisted projects; and,

WHEREAS, the FTA requires the City of Galveston to provide documentation and certification that the city has the legal capacity to carry out FTA funded programs and projects. This requirement is satisfied pursuant to a Legal Opinion from the City Attorney's office and a Resolution of City Council accepting the legal opinion and committing the city to compliance with the terms of any award received; and,

WHEREAS, the City Attorney has provided its opinion in the attachment labeled herein as "Legal Opinion", which is fully incorporated for all intents and purposes. The legal opinion affirms that the City of Galveston is a designated recipient and has the legal capacity to carry out FTA funded programs and projects and is eligible and authorized to request, receive and spend FTA funds to administer FTA assisted projects; and,

WHEREAS, the City Council of the City of Galveston has reviewed the City Attorney's Opinion and accepts and agrees with said opinion, that the City of Galveston has the legal capacity to carry out FTA funded programs and projects and is eligible and authorized to request, receive and spend FTA funds to administer FTA assisted projects; and,

WHEREAS, the City Council of the City of Galveston deems it in the public interest to accept the legal opinion of the City Attorney as to the city's eligibility and authority under state or local law to request, receive and spend Federal Transit Authority (FTA) funds, and its capacity to carry out FTA funded programs and projects.

NOW, THEREFORE, BE IT RESOLVED BY THE CITY COUNCIL OF THE CITY OF GALVESTON, TEXAS:

SECTION 1. The findings and recitations set out in the preamble of this Resolution are found to be true and correct and are hereby adopted by the City Council and made a part hereof for all purposes.

SECTION 2. The City Council of the City of Galveston hereby accepts the legal opinion of the City Attorney as to the city’s eligibility and authority under state or local law to request, receive and spend Federal Transit Authority (FTA) funds, and its capacity to carry out FTA funded programs and projects.

SECTION 3. The City Manager or designee is authorized, and upon final approval of the City Attorney, to execute those documents pertaining to the FTA funded grant applications, activities and programs.

SECTION 4. The City Secretary shall send a certified copy of this Resolution and accompanying legal opinion in satisfaction of the requirements of the FTA’s, “Transportation Award Management System” (TrAMS), program.

SECTION 5. This Resolution shall be and become effective from and after its adoption in accordance with the provisions of the Charter of the City of Galveston.

APPROVED AS TO FORM:

DONNA M. FAIRWEATHER
SR. ASSISTANT CITY ATTORNEY

I, Janelle Williams, Secretary of the City of Council of the City of Galveston, do hereby certify that the foregoing is a true and correct copy of a Resolution adopted by the City Council of the City of Galveston and its Regular meeting held on February 27, 2025, as the same appears in records of this office.

IN TESTIMONY WHEREOF, I subscribe my name hereto officially under the corporate seal of the City of Galveston this ___ day of _____, 2025.

Secretary for the City Council
of the City of Galveston

ATTACHMENT / EXHIBIT FOLLOWS



U.S. Department
of Transportation

**Federal Transit
Administration**

Headquarters

1200 New Jersey Avenue, SE
Washington, DC 20590

December 6, 2024

Dear Colleague:

FTA is pleased to announce the release of a recent enhancement in TrAMS, FTA's grants management system of record, specific to the organization and labeling of recipient documents. As you are aware, one of the prerequisites to be a recipient of FTA funding is demonstrating legal capacity to carry out the project(s) included in federal assistance awards. This is generally based on the review of the recipient organization's documentation and certification that it has the legal capacity to carry out FTA-funded programs and projects. Specifically, the recipient must be eligible and authorized under state or local law to request, receive, and spend FTA funds to administer FTA-assisted projects.

- **Opinion of Counsel:** Each recipient must be legally empowered to carry out the activities specified in the award.
- **Authorizing Resolution:** Each recipient organization must have a resolution or equivalent, from the recipient's Board of Directors or equivalent Authorizing Official, to be responsible for applying for assistance and legally committing the applicant or recipient to compliance with terms of an award.

This enhancement provides updated document labels within the Recipient Document profile module for these two required documents, as well as includes an enhanced search functionality for all users to find important documents that may be uploaded in their profile. In an effort to assist with the rollout of this enhancement, TrAMS has attempted to proactively label any documents that were named using these terms for the recipient. However, all recipients are asked to review and confirm that the correct document was properly labeled by the system. Additionally, if the system was unable to locate a document labeled using these terms, recipients must locate and properly identify both documents within their Recipient profile.

Beginning **March 5, 2025**, TrAMS will prevent any recipients that have not properly identified the Opinion of Counsel and Authorizing Resolution in their Recipient Document profile from transmitting or submitting new applications unless they have correctly labeled and/or uploaded their required legal documents.

To prevent any grant making delays please confirm and/or upload in TrAMS current copies of your Authorizing Resolution and Opinion of Counsel for your organization. This can be completed by selecting your organizations record using your Recipient ID under Recipient Organizations. Once your organization has been selected, next click on Related Actions and select the Recipient Documents field. Finally confirm or upload each document using the Opinion of Counsel and Authorizing Resolution Document Types. Information on this enhancement and a short tutorial video are available on [FTA's TrAMS webpage](#).

Sincerely,

Bruce Robinson

Bruce Robinson
Associate Administrator
Office of Program Management
Federal Transit Administration



City of Galveston

FLEET, MASS TRANSIT & SPECIAL EVENTS STAFF REPORT

Date February 18, 2025

To: City Manager
Mayor and City Council Members

From: David Smith, Executive Director
Fleet, Mass Transit and Special Events

Project location: N/A **Project:** Siddons Martin Emergency Group - Co-op

Request: Consider for the approval allowing the purchasing of parts and services utilizing the Buy Board Cooperative Purchasing contract with Siddons Martin Emergency Group (contract 698-23/746-24) and authorize the City Managers staff to execute the agreement upon final approval by the City Attorney.

Prior Council Action

No prior actions on this item.

Background

- A. The City of Galveston is a member of the Buy Board cooperative purchasing program, which allows the city to utilize contracts that have been competitively bid.
- B. The contracts were solicited and awarded by Buy Board and this allows the city to utilize contracts that have been competitively procured in compliance with state purchasing requirements.
- C. Texas Government Code Chapter 791 authorizes local governments to contract with each other and any agencies of the State of Texas.
- D. The objective of a cooperative purchasing program is to provide a mechanism for local governments to pool their collective purchasing power. Purchasing cooperatives save money in two ways: the price of the product and/or in the administrative cost savings from advertising for a formal solicitation.
- E. The services within the cooperative contract that will be utilized will be the annual purchase, installation, and repairing of emergency equipment on the city fleet. Other services will include parts and services to Fire Department vehicles.





City of Galveston

FLEET, MASS TRANSIT & SPECIAL EVENTS STAFF REPORT

Fiscal Impact Report

Requested by	David Smith Executive Director
Funding Source	Garage Parts and Outside Repairs Accounts
Cost	The estimated annual cost is \$50,000. #6401
Savings Estimation	Will reduce unit repair costs and reduce vehicle downtime.

Alternatives

- A. Approve the recommendation.
1. Cost - estimated to exceed \$15,000 annually. (City Charter)
 2. Timing - the contract is needed as soon as possible.
 3. Departmental Improvements - will provide the city with parts and services at the lowest contracted price and expedite the purchasing and delivery process.
- B. Do not approve the recommendation.
1. Cost - estimated to exceed \$15,000 annually. (City Charter)
 2. Timing - purchases made on an *as needed basis*.
 3. Departmental Improvements - will provide the city with parts and services at an increased price, plus delays in the approval and delivery process.

Staff Recommendation

Concur in *Alternative A* and approve allowing the purchasing of parts and services utilizing the Buy Board Cooperative Purchasing contract with Siddons Martin Emergency Group (contract 698-23/746-24) and authorize the City Managers staff to execute the agreement upon final approval by the City Attorney.

Attachments





Vendor Contract Information Summary

Vendor	Siddons Martin Emergency Group, LLC
Contact	Jeffrey Doran
Phone	1-800-784-6806
Email	omt@siddons-martin.com
Vendor Website	www.siddons-martin.com
TIN	27-4333590
Address Line 1	1362 East Richey
Vendor City	Houston
Vendor Zip	77073
Vendor State	TX
Vendor Country	USA
Delivery Days	10
Freight Terms	FOB Destination
Payment Terms	net due upon delivery
Shipping Terms	Freight prepaid by vendor and added to invoice
Ship Via	Other
Designated Dealer	No
EDGAR Received	Yes
Service-disabled Veteran Owned	No
Minority Owned	No
Women Owned	No
National	No
No Foreign Terrorist Orgs	Yes
No Israel Boycott	Yes
MWBE	No
ESCs	All Texas Regions
States	All States
Contract Name	Fire Service Apparatus Vehicles
Contract No.	746-24
Effective	10/01/2024
Expiration	09/30/2027
Accepts RFQs	Yes
Service Fee Note	Vehicle purchase orders are subject to a \$1500 service fee
Return Policy	Parts may be returned unused, and the vehicle may not be returned



Vendor Contract Information Summary

Vendor Siddons Martin Emergency Group, LLC
Contact Jeffrey Doran
Phone 800-784-6806
Email jdoran@siddons-martin.com
Vendor Website www.siddons-martin.com
TIN 27-4333590
Address Line 1 1362 East Richey
Vendor City Houston
Vendor Zip 77073
Vendor State TX
Vendor Country USA
Delivery Days 10
Freight Terms FOB Destination
Payment Terms net due upon delivery
Shipping Terms Freight prepaid by vendor and added to invoice
Ship Via Common Carrier
Designated Dealer No
EDGAR Received Yes
Service-disabled Veteran Owned No
Minority Owned No
Women Owned No
National No
No Foreign Terrorist Orgs Yes
No Israel Boycott Yes
MWBE No
ESCs All Texas Regions
States All States
Contract Name Public Safety and Firehouse Supplies and Equipment
Contract No. 698-23
Effective 04/01/2023
Expiration 03/31/2026
Accepts RFQs Yes
Return Policy Returns may incur restocking fees



City of Galveston

FLEET, MASS TRANSIT & SPECIAL EVENTS STAFF REPORT

Date	February 18, 2025
To:	City Manager Mayor and City Council Members
From:	David Smith, Executive Director Fleet, Mass Transit and Special Events
Project location:	N/A
Project:	Sun Coast Resources - Co-op Fuel Supply

Request: Consider allowing the purchasing of bulk fuel by the Fleet Facility utilizing the TASB Energy Cooperative Purchasing contract with Sun Coast Resources and authorize the City Managers staff to execute the agreement upon final approval by the City Attorney.

Prior Council Action

No prior actions on this item.

Background

- A. The City of Galveston is a member of the TASB Energy Cooperative Purchasing Program, which allows the city to utilize contracts that have been competitively bid.
- B. The contracts were solicited and awarded by TASB and this allows the city to utilize agreements that have been competitively procured in compliance with state purchasing requirements.
- C. Texas Government Code Chapter 791 authorizes local governments to contract with each other and any agencies of the State of Texas.
- D. The objective of a cooperative purchasing program is to provide a mechanism for local governments to pool their collective purchasing power. Purchasing cooperatives save money in two ways: the price of the product and/or in the administrative cost savings from advertising for a formal solicitation.
- E. The City of Galveston supplies fuel for its own fleet, and in addition, to outside organizations including the County, Sheriff's Department, Health District (EMS), Port of Galveston, Parks Board, Bayou Vista, Jamaica Beach, and the Navigation District.





City of Galveston

FLEET, MASS TRANSIT & SPECIAL EVENTS STAFF REPORT

- F. The City of Galveston currently has a contract for its wholesale bulk fuel supply with Petroleum Traders Corporation who subcontracts the deliveries utilizing Houston based fuel transport (tanker) companies. At certain periods of time, Petroleum Traders has not been able to deliver fuel, as well as our backup fuel suppliers who work under the same business model.
- G. Petroleum Traders is one of the largest wholesale fueling companies in the United States and does offer wholesale fuel at very low prices and was awarded the contract through the city's bidding process.
- H. Sun Coast Resources is a Houston based fuel supplier that has their own fuel supply, fleet of fuel transport tankers and drivers that are available 24/7 to provide emergency competitively bid fueling during troubled time periods such as natural disasters, shortages of products, shortage of tankers or drivers, and/or other various situations.

Fiscal Impact Report

Requested by	David Smith Executive Director
Funding Source	Fuel Accounts
Cost	\$15,000 plus (not to exceed budgeted amounts)
Savings Estimation	Will supply the city with emergency competitively bid fuel during troubled time periods.

Alternatives

- A. Approve the recommendation.
 - 1. Cost - estimated to exceed \$15,000 annually. (City Charter)
 - 2. Timing - agreement is needed as soon as possible.
 - 3. Departmental Improvements - will provide a backup fuel plan during troubled time periods.
- B. Do not approve the recommendation.





City of Galveston

FLEET, MASS TRANSIT & SPECIAL EVENTS STAFF REPORT

1. Cost - N/A
2. Timing - N/A
3. Departmental Improvements - none

Staff Recommendation

Concur in *Alternative A* and approve the purchasing of bulk fuel by the Fleet Facility utilizing the TABS Energy Cooperative Purchasing contract with Sun Coast Resources and authorize the City Managers staff to execute the agreement upon final approval by the City Attorney.



TASB Energy Cooperative Fuel Program

Enables Cooperative members to acquire unleaded gasoline, diesel, or propane through spot purchases or the fixed-rate fuel program (unleaded gasoline and diesel only).

Save money on the gasoline, diesel, and propane you use every day with TASB Energy Cooperative's fuel program. Members of the fuel program have three purchasing options:

1. Make spot purchases.
 - Rack-rate unleaded gasoline or diesel
 - OPIS-rate unleaded gasoline or diesel
 - Index rate propane
2. Participate in the fixed-rate fuel program.
 - Lock in fuel rates (unleaded gasoline and/or diesel) at a fixed rate for a specified period under a fuel purchase agreement with an awarded vendor of the Cooperative.
3. Combine both options.

Purchasing Power

The TASB Energy Cooperative offers fuel options based on your preferences, needs, and value. By combining purchasing power, members may receive bulk rates based on current market prices for fuel. Each year members purchase more than 15 million gallons of fuel through the Cooperative.

Stability and Budget Certainty

Under the Energy Cooperative's fixed-price fuel program, members can lock unleaded gasoline and diesel rates for a specified time under a purchase agreement with awarded vendors. Purchasing

fuel at a fixed rate decreases the effects of market volatility and assists with more accurate budgeting.

Fuel Pooling

The TASB Energy Cooperative's annual spring fuel pool is an opportunity to leverage our strength in numbers and secure the best price available for fuel purchases. As one of the biggest aggregators of fuel in Texas, the TASB Energy Cooperative offers our members an opportunity to take advantage of fixed-rate pricing that has been competitively bid. The volume of aggregation allows our vendors the ability to find the best price available for our participants. Gain peace of mind knowing that we award vendor contracts through a transparent and competitive procurement process to help you stay compliant with Texas local and state procurement requirements.

Members of TASB Energy Cooperative's fuel and electricity programs are eligible to participate. Even if you aren't enrolled in the fuel program currently, you're still eligible to participate as long as you have a signed Interlocal Participation Agreement (IPA) on file with us. Since the TASB Energy Cooperative is board-governed, each year the fuel pool must be approved by the board to move forward and execute the pool. To learn more about the fuel pool and if participation may benefit your organization, watch our collaborative webinar series, [Insights on Fuel Pooling](#). For questions, contact Adrian Porras at adrian.porras@tasb.org or 512-293-5086.

Awarded Fuel Providers

TASB Energy Cooperative has several awarded fuel vendors to provide members with competitive pricing and value on their fuel purchases.

Propane

- [AmeriGas Propane, L.P.](#)
- [Ferrell Gas](#)

Fuel: Fixed, Rack and OPIS

- [Colonial Oil Industries, Inc.](#)
- [Mansfield Energy](#)

Fuel: OPIS Only

- [Sun Coast Resources, Inc](#)

[Have Questions? Contact Us](#)

Membership Information

TASB Active Membership

Active Members consist of the boards of Texas public school districts and education service centers. They have voting privileges in the Association and may participate in all of TASB's services.

TASB Energy Cooperative Membership

Lock in budget certainty with competitive fixed rates on electricity, transportation fuels, and other types of commodities through TASB Energy Cooperative.

TASB Associate Membership

Associate Members consist of shared service arrangements, community colleges, and central appraisal districts.

TASB Affiliate Membership

Affiliate Members are open-enrollment and college/university charter schools in Texas.

Contact Information

TASB Energy Cooperative

energy@tasb.org

[800-580-8272 x2024](tel:800-580-8272)



City of Galveston

FLEET, MASS TRANSIT & SPECIAL EVENTS STAFF REPORT

Date February 18, 2025

To: City Manager
Mayor and City Council Members

From: David Smith, Executive Director
Fleet, Mass Transit and Special Events

Project location: City Fueling Sites

Project: Liberty Equipment Sales - Co-op

Request: Consider for the approval allowing the purchasing of fuel station parts and services utilizing the Choice Partners Cooperative Purchasing contract with Liberty Equipment Sales (contract 24/016MR-03) and authorize the City Managers staff to execute the agreement upon final approval by the City Attorney.

Prior Council Action

No prior actions on this item.

Background

- A. The City of Galveston is a member of the Choice Partners Cooperative purchasing program, which allows the city to utilize contracts that have been competitively bid.
- B. The contracts were solicited and awarded by Choice Partners Cooperative, and this allows the city to utilize contracts that have been competitively procured in compliance with state purchasing requirements.
- C. Texas Government Code Chapter 791 authorizes local governments to contract with each other and any agencies of the State of Texas.
- D. The objective of a cooperative purchasing program is to provide a mechanism for local governments to pool their collective purchasing power. Purchasing cooperatives save money in two ways: the price of the product and/or in the administrative cost savings from advertising for a formal solicitation.





City of Galveston

FLEET, MASS TRANSIT & SPECIAL EVENTS STAFF REPORT

- E. Liberty Equipment Sales is an authorized dealership for Fuel Force systems, which is the software and hardware that controls the fueling sites, pumps, tanks, and associated equipment.
- F. The services within the cooperative contract will include the repair and/or parts purchasing for fueling sites during the fiscal year.

Fiscal Impact Report

Requested by	David Smith Executive Director
Funding Source	Garage Parts and Outside Repairs Accounts
Cost	The estimated cost - \$50,000. #30819
Savings Estimation	Will reduce unit repair costs and equipment downtime.

Alternatives

- A. Approve the recommendation.
 - 1. Cost - estimated to exceed \$15,000 annually. (City Charter)
 - 2. Timing - the contract is needed as soon as possible.
 - 3. Departmental Improvements - will provide the city with parts and services at the lowest contracted price and expedite the purchasing and delivery process.
- B. Do not approve the recommendation.
 - 1. Cost - estimated to exceed \$15,000 annually. (City Charter)
 - 2. Timing - purchases made on an *as needed basis*.
 - 3. Departmental Improvements - will provide the city with parts and services at an increased price, plus delays in the approval and delivery process.





City of Galveston

FLEET, MASS TRANSIT & SPECIAL EVENTS STAFF REPORT

Staff Recommendation

Concur with *Alternative A* and approve allowing the purchasing of fuel station parts and services utilizing the Choice Partners Cooperative Purchasing contract with Liberty Equipment Sales (contract 24/016MR-03) and authorize the City Managers staff to execute the agreement upon final approval by the City Attorney.

Attachments





Choice Partners national purchasing coopera offers quality, legal procurement and contrac solutions to meet government purchasing requirements. We also meet all cooperative requirements of the **EDGAR/Uniform Guidance CFR 200!**

[Member Login](#)



[Vendor Login](#)

877.696.2122

[Home](#)

[About Us](#)

[Members](#)

[Vendors](#)

[Services](#)

[Bidders/RFPs](#)

[Vendors](#)

[Available Contracts](#)

[Liberty Equipment Sales, Inc](#)

[Print Info.](#)

Liberty Equipment Sales, Inc

Contract Category: Fuel and Lubricants

Contract Partner: Liberty Equipment Sales, Inc

Contract Number: 24/016MR-03

Contract Terms:

Initial Award Date: January 17, 2024

1st Renewal Start Date: January 17, 2025

Current Expiration Date: January 16, 2026

Renewal Options Remaining: 3

CP Contract Manager:

Michael Robles

Michael@choicepartners.org

713-316-4254



Contract Partner Web Site:

<http://www.libertyequipmentsales>

Approved Market Area: TX

APPROVED PRODUCT OR SERVICE: This vendor does not provide fuel. Only lubricants and equipment.

HUB Status: Yes

MWBE Status: Yes

SBE Status: No

VOB Status: No

ABOUT THIS PARTNER:

Liberty Equipment Sales, Inc. is a service station and petroleum equipment distributor based in Houston, TX. We are a small women-owned business committed to providing our services with your satisfaction in mind.

We specialize in offering a wide range of petroleum equipment and fueling systems services to our customers. Our technicians have extensive experience, certifications, and state licenses, making them more than qualified for the job.

To see contract information details, please login.

If you are a **Member**, [please login here](#).



City of Galveston

FLEET, MASS TRANSIT & SPECIAL EVENTS STAFF REPORT

Date February 17, 2025

To: City Manager
Mayor and City Council Members

From: David Smith, Executive Director
Fleet, Mass Transit and Special Events

Project location: N/A **Project:** GPD Unit Purchase Package - Silsbee

Request: Consider for the approval allowing the Fleet Facility to purchase the listed rolling stock (police service units) and associated equipment from Silsbee Ford through Tips Co-op for a total price of \$422,663.90 and authorize the City Managers staff to execute the contract upon final approval by the City Attorney.

Prior Council Action

No prior actions on this item.

Background

- A. Funding for new equipment has been identified and budgeted for the listed departments.
- B. These new vehicles will replace units which have been flagged by the Vehicle Replacement Program. Those units will be cleaned and auctioned off benefiting the city coffers. Some may be reclassified as pool units.
- C. The Vehicle Replacement Program scores vehicles by analyzing their age, mileage and operational costs and flags equipment that has reached preset limitations for its classification.
- D. TIPS is a cooperative purchasing organization that the city is a member of that performs large procurement bid packages for local governments. The contract number is 240907.
- E. The requested vehicle descriptions, price breakdown, assignments and the estimated delivery periods are listed below.
- F. The extended purchase price for this package is \$422,663.90.





City of Galveston

FLEET, MASS TRANSIT & SPECIAL EVENTS STAFF REPORT

- G. Additional equipment will be added by the dealer that was identified in the specification process as requested by the department.

Fiscal Impact Report

QUOTE	REPLACES UNIT	DESCRIPTION	DEPT	EST DELIVERY	FUND	QUOTE
A	1750	2025 FORD INTERCEPTOR	PATROL	3RD QUARTER (CALENDAR)	GEN FUND VCO	\$ 64,107.93
A	1914	2025 FORD INTERCEPTOR	PATROL	3RD QUARTER (CALENDAR)	GEN FUND VCO	\$ 64,107.93
A	2002	2025 FORD INTERCEPTOR	PATROL	3RD QUARTER (CALENDAR)	GEN FUND VCO	\$ 64,107.93
A	1916	2025 FORD INTERCEPTOR	PATROL	3RD QUARTER (CALENDAR)	GEN FUND VCO	\$ 64,107.93
A	1332	2025 FORD INTERCEPTOR	PATROL	3RD QUARTER (CALENDAR)	GEN FUND VCO	\$ 64,107.93
						\$320,539.65
B	2232	2024 FORD EXPEDITION	PATROL	IN STOCK	GEN FUND VCO + INS	\$ 60,643.00
C	1042	2024 EXPRESS 2500 VAN	SP SERVICE / PATROL	IN STOCK	GEN FUND VCO	\$ 41,481.25
					EXTENDED TOTAL	\$422,663.90

Alternatives

- A. The City Council approves the purchase.
- Cost - \$422,663.90
 - Timing - Delivery period listed above.
 - Divisional Improvements - Will provide the city with needed equipment to perform duties. Newer equipment will reduce fleet maintenance costs and will improve efficiency.
- B. The City Council does not approve the purchase.
- Cost - No additional cost at this time.
 - Timing - N/A
 - Divisional Improvements - City staff will not be able to function without needed equipment. Older equipment will take on a heavier load, which will increase maintenance costs and efficiencies will be reduced.

Staff Recommendation





City of Galveston

FLEET, MASS TRANSIT & SPECIAL EVENTS STAFF REPORT

Concur in Alternative A and approve allowing the Fleet Facility to purchase the listed rolling stock (service trucks) and associated equipment from Silsbee Ford through Tips Co-op for a total price of \$422,663.90 and authorize the City Managers staff to execute the contract upon final approval by the City Attorney.

Attachments





A

PRODUCT PRICING SUMMARY
TIPS USA 240901 TRANSPORTATION VEHICLES
VENDOR- Silsbee Ford, 1211 Hwy 96 N., Silsbee TX 77656

End User: <u>CITY OF GALVESTON</u>	Prepared by: <u>RICHARD HYDER</u>
Contact: <u>DAVID SMITH 409.789.0673</u>	Phone: <u>409.300.1385</u>
Email: <u>DSMITH@GALVESTONTX.GOV</u>	Email: <u>RHYDER.COWBOYFLEET@GMAIL.COM</u>
Product Description: <u>FORD INTERCEPTOR UTILITY GAS</u>	Date: <u>February 4, 2025</u>

A. Bid Item: 54 A. Base Price: \$ 47,395.00

B. Factory Options

Code	Description	Bid Price	Code	Description	Bid Price
K8A	2025 FORD INTERCEPTOR UTILITY AWD	\$ 1,595.00		REMOTE KEYLESS ENTRY FOBS	\$ -
99B	3.3L V6 GAS	\$ -		WIRELESS PHONE CONNECTIVITY	\$ -
51R	DRIVER SIDE LED SPOTLIGHT	\$ 400.00		GRILL/SIREN PREWIRE	\$ -
	FRONT HEADLAMP HOUSING	\$ -		REAR VIEW CAMERA	\$ -
	POLICE TAIL LAMP HOUSING	\$ -			
	REAR AIR CONDITIONING	\$ -			
YZ	EXTERIOR WHITE	\$ -			
96	CLOTH FRONT VINYL REAR SEATING	\$ -			

Total of B. Published Options: \$ 1,995.00

Published Option Discount (5%): \$ (99.75)

C. Unpublished Options

Description	Bid Price	Options	Bid Price
SILSBEE INSTALL GALVESTON 013025	\$ 13,257.68		
ALPHA GRAPHICS #4066	\$ 1,360.00		

Total of C. Unpublished Options: \$ 14,617.68

D. Floor Plan Interest (for in-stock and/or equipped vehicles):	\$ -
E. Lot Insurance (for in-stock and/or equipped vehicles):	\$ -
F. Contract Price Adjustment:	\$ -
G. Additional Delivery Charge: <u>100</u> miles	\$ 200.00
H. Subtotal:	\$ 64,107.93
I. Quantity Ordered <u>5</u> x H =	\$ 320,539.65
J. Trade in:	\$ -
K. Total Purchase Price	\$ 320,539.65

QUOTE

A

AGENCY
DATE QUOTED
SALESMAN

CITY OF GALVESTON
30-Jan-25
RICHARD HYDER

PART NUMBER		DESCRIPTION	UNIT PRICE	EXT PRICE
		2025 FORD PI UTILITY		
W.EB2SP3JPKG	1	LEGACY LIGHTBAR	\$ 2,395.00	\$ 2,395.00
W.C3997	1	CENCOM CORE W/21 PB CONTROLLER		INC
W.C399K1	1	OBD II CANPORT		INC
W.SA315U	1	100W SPEAKER	\$ 212.52	\$ 212.52
W.SAK1	1	SPEAKER BRACKET	\$ 31.12	\$ 31.12
W.CHWLF29	1	WECANX HOWLER	\$ 573.80	\$ 573.80
W.TLI3JC	2	T-SERIES ION RBW (NEAR HEADLAMP)	\$ 126.00	\$ 252.00
W.MCRNTJ	2	MICRON R/B (GRILL CUTOUT)	\$ 94.88	\$ 189.76
HAV.C-VS-1210-INUT	1	HAVIS CONSOLE	\$ 349.75	\$ 349.75
HAV.CUP2-1001	1	DUAL CUP HOLDER	\$ 45.77	\$ 45.77
HAV.C-ARM-102	1	ARM REST	\$ 64.21	\$ 64.21
HAV.C-LP2-USB-BL2	1	12V OUTLET/USB POWER FACEPLATE	\$ 106.56	\$ 106.56
HAV.C-MC	2	MIC CLIP	\$ 21.86	\$ 43.72
HAV.C-MCB	2	MIC CLIP BRACKET	\$ 25.96	\$ 51.92
HAV.C-EB30-MMT-1P	1	RADIO FACEPLATE		INC
HAV.C-EB40-CCS-1P	1	CENCOM FACEPLATE		INC
HAV.C-AP-0325-1	1	3" ACCESSORY POCKET	\$ 34.84	\$ 34.84
HAV.C-FP-3	2	3" BLANK		INC
HAV.C-HDM-303	1	HD TOP OFFSET PLATFORM FOR MDC	\$ 75.58	\$ 75.58
HAV.C-MD-204	1	8.5" TELESCOPING POLE ASSY	\$ 166.90	\$ 166.90
HAV.DS-PAN-432-2	1	DOCKING STATION	\$ 1,039.70	\$ 1,039.70
BRO.LB3692	1	PRINTER POWER CABLE	\$ 43.50	\$ 43.50
BRO.RJ4250WBL	1	BROTHER PRINTER	\$ 902.75	\$ 902.75
LI.PRKBTRJ42B	1	BROTHER PRINTER MOUNT BRACKET	\$ 149.11	\$ 149.11
SET.PK1126ITU20	1	SETINA PARTITION	\$ 789.56	\$ 789.56
SET.PK0123ITU202ND	1	CARGO BARRIER	\$ 435.81	\$ 435.81
SET.QK0634ITU20	1	PRISONER SEAT W/OSB	\$ 744.40	\$ 744.40
SET.WK0514ITU20	1	WINDOW ARMOR	\$ 247.64	\$ 247.64
911.CH15	1	911 15 CIRCUIT HARNESS	\$ 546.48	\$ 546.48
911.SAPD	1	PASS-THROUGH HARNESS	\$ 68.50	\$ 68.50
TES.453440	1	17' NMO COAX	\$ 18.90	\$ 18.90
TES.204468	1	800MHZ ANTENNA	\$ 46.69	\$ 46.69
TES.55279	1	ADAPTER	\$ 8.35	\$ 8.35
SS.26108	1	12V 100A BREAKER	\$ 57.84	\$ 57.84
SET.GK10342U	1	DUAL T-RAIL GUNLOCK	\$ 485.00	\$ 485.00
		PARTS		\$ 10,177.68
		INSTALLATION		\$ 2,880.00
		SHOP SUPPLIES		\$ 100.00
		FREIGHT		\$ 100.00
		TOTAL		\$ 13,257.68



B

PRODUCT PRICING SUMMARY
TIPS USA 240901 TRANSPORTATION VEHICLES
VENDOR- Silsbee Ford, 1211 Hwy 96 N., Silsbee TX 77656

End User: CITY OF GALVESTON

Prepared by: RICHARD HYDER

Contact: JOHN FESLER

Phone: 409.300.1385

Email: _____

Email: RHYDER.COWBOYFLEET@GMAIL.COM

Product Description: FORD EXPEDITION SSV

Date: February 5, 2025

A. Bid Item: 17

A. Base Price: \$ **54,195.00**

B. Factory Options

Code	Description	Bid Price	Code	Description	Bid Price
UIG	2024 FORD EXPEDITION SSV 4X4 REG LEV	\$ 3,000.00	18B	RUNNING BOARDS	\$ -
99T	3.5L V6 ECOBOOST	\$ -			
	EXTERIOR WHITE	\$ -			
CE	INTERIOR GRAY CLOTH BUCKETS FRON	\$ -			
	REMOTE KEYLESS ENTRY	\$ -			
	REAR AIR CONDITIONING	\$ -			
	NO CENTER CONSOLE	\$ -			
	VINYL FLOORING	\$ -			
102A	SSV SEATING FOR 5	\$ -			
Total of B. Published Options:					\$ 3,000.00

Published Option Discount (5%) \$ **(150.00)**

C. Unpublished Options

Description	Bid Price	Options	Bid Price
WHELEN AVENGER R/B PASS SIDE WINDSHIELD	\$ 375.00		
LIGHTED ROCKER SWITCH	\$ 5.00		
PROCELL 1/2 PARTITION W/ CARGO BARRIER	\$ 2,118.00		
INSTALLATION	\$ 900.00		
I LIKE THIS IN STOCK			
Total of C. Unpublished Options:			\$ 3,398.00

D. Floor Plan Interest (for in-stock and/or equipped vehicles): \$ -

E. Lot Insurance (for in-stock and/or equipped vehicles): \$ -

F. Contract Price Adjustment: \$ -

G. Additional Delivery Charge: 100 miles \$ **200.00**

H. Subtotal: \$ **60,643.00**

I. Quantity Ordered 1 x H = \$ **60,643.00**

J. Trade in: \$ -

K. Total Purchase Price \$ **60,643.00**



PRODUCT PRICING SUMMARY
TIPS USA 240901 TRANSPORTATION VEHICLES
VENDOR- 5426 LAKE COUNTRY CHEVROLET, 2152 N. WHEELER STREET JASPER, TX 75951

End User: CITY OF GALVESTON
Contact: DAVID SMITH 409.789.0673
Email: DSMITH@GALVESTONTX.GOV
Product Description: CHEVROLET EXPRESS CARGO

Prepared by: RICHARD HYDER
Phone: (409) 300-1385
Email: rhyder.cowboyfleet@gmail.com
Date: February 4, 2025

A. Bid Item: CG23405 17 **A. Base Price:** \$ 38,800.00

B. Factory Options

Code	Description	Bid Price	Code	Description	Bid Price
	2024 EXPRESS 2500 CARGO VAN	\$ 1,995.00		EXTERIOR - WHITE	
	135" WHEELBASE			INTERIOR - GRAY VINYL	\$ -
LV3	4.3L V6 ENGINE	\$ -			
	POWER WINDOWS / LOCKS	\$ -			
ZQ3	DRIVER CONVENIENCE PACKAGE	\$ 395.00			
ZW3	REAR DOOR GLASS	\$ 130.00			
UD7	REAR PARK ASSIST	\$ 295.00			
UFT	SIDE BLIND ZONE ASSIST	\$ 395.00			
ATG	KEYLESS ENTRY	\$ 125.00			
Total of B. Published Options:					\$ 3,335.00

Published Option Discount (5%): \$ (60.75)

C.

Description	Bid Price	Options	Bid Price
DARK WINDOW TINT REAR GLASS	\$ 95.00		
5 LIKE THIS IN STOCK			
Total of C. Unpublished Options:			\$ 95.00

D. Floor Plan Interest (for in-stock and/or equipped vehicles): \$ -

E. Lot Insurance (for in-stock and/or equipped vehicles): \$ -

F. Contract Price Adjustment: 2024 MODEL INCENTIVE \$ (1,000.00)

G. Additional Delivery Charge: 156 miles \$ 312.00

H. Subtotal: \$ 41,481.25

I. Quantity Ordered 1 x H = \$ 41,481.25

J. Trade in: \$ -

K. Total Purchase Price \$ 41,481.25

The Interlocal Purchasing System

Purchasing Made Personal



Printed 17 February 2025



Silsbee Fleet (4 locations) 1.Silsbee Ford 2.Silsbee Toyota 3.

B U AUTOMATED VENDOR /U (DO NOT SEND PO TO TIPS) EMAIL PURCHASE ORDER TO:
sgamblin.silsbeefleet@gmail.com

	<u>PAYMENT TO</u>	<u>TIPS CONTACT</u>
ADDRESS	1396 HWY 327 E	NAME Charlie Martin
CITY	SILSBEE	PHONE (866) 839-8477
STATE	TX	FAX (866) 839-8472
ZIP	77656	EMAIL tips@tips-usa.com

DISADVANTAGED/MINORITY/WOMAN BUSINESS ENTERPRISE: N

HUB: N

SERVING STATES

AL | AK | AZ | AR | CA | CO | CT | DE | DC | FL | GA | HI | ID | IL | IN | IA | KS | KY | LA | ME | MD | MA | MI | MN | MS | MO | MT | NE | NV | NH | NJ | NM | NY | NC | ND | OH | OK | OR | PA | RI | SC | SD | TN | TX | UT | VT | VA | WA | WI | WY | PR

Overview

FLEET VEHICLES

AWARDED CONTRACTS "View EDGAR Doc" on Website

Contract	Comodity	Exp Date	EDGAR
240902	Transportation Vehicle Parts and Services	11/30/2027	See EDGAR Certification Doc.
240901	Transportation Vehicles	11/30/2027	See EDGAR Certification Doc.

CONTACTS BY CONTRACTS

240901

SETH GAMBLIN Sales (512) 436-1313 sgamblin.silsbeefleet@gmail.com

240902

Seth Gamblin Sales (512) 436-1313 sgamblin.silsbeefleet@gmail.com



City of Galveston

DEPARTMENT OF ENGINEERING

Robert L. Winiecke, P.E., CFM, Director of Infrastructure & Engineering
rwiniecke@galvestontx.gov | Office Number: (409) 797-3664 | www.galvestontx.gov

Date February 27, 2025

To: Brian Maxwell, City Manager
Honorable Mayor and City Council Members

From: Robert L. Winiecke, P.E., CFM, Director of Infrastructure & Engineering

Project Location: Galveston Causeway

Project: Blanket Lighting Maintenance Agreement

Request: Consider Adopting Resolution #25-____ approving a Blanket Lighting Maintenance Agreement with the Texas Department of Transportation (TxDOT) for a Continuous Lighting System Installation project, regarding Installation and Continued Maintenance of a Continuous Lighting Systems in Areas within the City of Galveston; Authorizing the City Manager to execute the Agreement and all other necessary documents upon final approval by the City Attorney; Directing the City Secretary to send a certified copy of this resolution to the Texas Department of Transportation; providing for findings of fact and for an effective date.

Prior Council Action

A. There has been no prior City Council Action on this item.

Background

- A. The City has requested that TxDOT contribute financial aid in the construction, maintenance, and operation of a continuous highway lighting system on freeways and expressways as defined in Section 25.11, Texas Administrative Code.
- B. TxDOT will construct said highway lighting system, conditioned that the city, as provided in Section 25.11, Texas Administrative Code and Article 6673b, Vernon's Texas Civil Statutes, will maintain and operate said lighting system.

Fiscal Impact Report

Operation and maintenance costs of the continuous lighting system will be covered by the appropriate line items in the City's General Fund.



Alternatives

1. Adopt this Resolution authorizing the city to enter into a Blanket Lighting Agreement with the Texas Department of Transportation for maintaining the proposed highway lighting system to be installed by the TxDOT on the Galveston Causeway.
2. Do not Adopt this Resolution and reject the funding opportunity being offered for this project.

Staff Recommendation

Staff recommends adopting Resolution #25-__ approving the city enter into the requested Blanket Lighting Maintenance Agreement.

Respectfully Submitted,



Robert L. Winiecke

Director of Infrastructure & Engineering

Attachments

Resolution #25-__
Blanket Lighting Maintenance Agreement

RESOLUTION NO. 25 - _____

A RESOLUTION OF THE CITY COUNCIL OF THE CITY OF GALVESTON, TEXAS, APPROVING A BLANKET LIGHTING MAINTENANCE AGREEMENT WITH THE TEXAS DEPARTMENT OF TRANSPORTATION (TXDOT) FOR A CONTINUOUS LIGHTING SYSTEM INSTALLATION PROJECT, REGARDING INSTALLATION AND CONTINUED MAINTENANCE OF A CONTINUOUS LIGHTING SYSTEM IN AREAS WITHIN THE CITY OF GALVESTON; AUTHORIZING THE CITY MANAGER TO EXECUTE THE AGREEMENT AND ALL OTHER NECESSARY DOCUMENTS UPON FINAL APPROVAL BY THE CITY ATTORNEY; DIRECTING THE CITY SECRETARY TO SEND A CERTIFIED COPY OF THIS RESOLUTION TO THE TEXAS DEPARTMENT OF TRANSPORTATION; PROVIDING FOR FINDINGS OF FACT AND FOR AN EFFECTIVE DATE.

WHEREAS, the City of Galveston requested, and was granted from the State, contribution of financial aid in the construction, maintenance and operation of a continuous highway lighting system (*herein* “Blanket Lighting” or “Continuous Lighting” System), on freeways and expressways pursuant to Texas Administrative Code (TAC) Section 25.11; and,

WHEREAS, pursuant to TAC 25.11(e), in a 100% method of financing agreement, the Texas Transportation Commission will fund the total cost of designing and installing the continuous lighting system, provided that the local government agrees to assume all of the cost of subsequent operation and maintenance of the lighting system; and,

WHEREAS, a continuous lighting system provides uniform illumination of a continuous section of a segment of the state highway system. The continuous lighting system will be predominately located along the IH45 Causeway between the Mainland and Galveston Island, within the City; and,

WHEREAS, pursuant to TAC 25.11, this Blanket Lighting Maintenance Agreement requires the city to adopt, by Resolution, the understanding and obligations between the parties and submit the same to the Texas Transportation Commission; and,

WHEREAS, the City will be responsible for the subsequent maintenance and operation of the continuous lighting systems per the agreement; and,

WHEREAS, the City Council of the City of Galveston, Texas, deems it in the public interest to enter into a Blanket Lighting Maintenance Agreement regarding the construction, maintenance, and operation of continuous highway lighting systems within the city, and to authorize the City Manager to execute those documents as required by the state.

NOW, THEREFORE, BE IT RESOLVED BY THE CITY COUNCIL OF THE CITY OF GALVESTON, TEXAS:

SECTION 1. The findings and recitations set out in the preamble to this Resolution are found to be true and correct and are hereby adopted by the City Council and made a part hereof for all purposes.

SECTION 2. The City Council of the City of Galveston, Texas hereby approves entering into a Blanket Lighting Maintenance Agreement for a continuous lighting system with the Texas Department of Transportation (TxDot).

SECTION 3. The City Council of the City of Galveston, Texas, hereby authorizes the City Manager to execute the Agreement and all other documents necessary for the City to participate in the Agreement, upon final approval by the City Attorney.

SECTION 4. The City Council of the City of Galveston, Texas, hereby directs the City Secretary to provide a certified copy of this Resolution, to be attached to the Agreement with TxDOT, and as required by the state.

SECTION 5. This Resolution shall be and become effective from and after its adoption.

APPROVED AS TO FORM:

DONNA M. FAIRWEATHER
SR. ASSIST. CITY ATTORNEY

I, Janelle Williams, Secretary of the City Council of the City of Galveston, do hereby certify that the foregoing is a true and correct copy of a Resolution adopted by the City Council of the City of Galveston at its Regular Meeting held on February 27, 2025, as the same appears in records of this office.

IN TESTIMONY WHEREOF, I subscribe my name hereto officially under the corporate seal of the City of Galveston this _____ day of _____, 2025.

Secretary for the City Council
of the City of Galveston



P.O. Box 1386 | Houston, Texas 77251-1386
713.802.5000
txdot.gov

January 15, 2025

Mr. Brian Maxwell
City Manager, City of Galveston
823 Rosenberg
P.O. Box 779
Galveston, Texas 77553

9489 0090 0027 6427 0528 71

RE: Blanket Lighting Maintenance Agreement

Dear Mr. Maxwell:

We are in receipt of a blanket lighting maintenance agreement sent by your office with only the executed signature.

We will need an ordinance passed by the city which was not included. There are dates missing for passing of city ordinance on the agreement for TxDOT to fully execute. The witness block of this agreement was not filled out.

Please provide an ordinance by the city and fill out the dates on the agreement.

If you have any questions, please contact, Mr. Gaurang Pandit at (713) 802-5856 or via email at Gaurang.Pandit@txdot.gov.

Sincerely,

Ugonna U. Ughanze, P.E.
Director of Transportation Operations
Houston District

Attachments

CC: Dan Buckley, City of Galveston
Marissa Barnett – City of Galveston
Sylvester E. Onwas, P.E., District Traffic Engineer, HOU, TxDOT
Gaurang S. Pandit, P.E., Transportation Engineer Supervisor, HOU, TxDOT
Mohammadrza Molaei, P.E., Transportation Engineer, HOU, TxDOT



P.O. BOX 1386 | HOUSTON, TEXAS 77251-1386 | 713.802.5000 | WWW.TXDOT.GOV

March 14, 2023

Mr. Brian Maxwell
City Manager
City of Galveston
823 Rosenberg
P.O. Box 779
Galveston, Texas 77553

RE: Blanket Lighting Maintenance Agreement

Dear Mr. Maxwell:

This pertains to the Lighting System installed and will be installed within the city limits of the City of Galveston. It is necessary that we have an executed agreement with City of Galveston concerning the maintenance of these lighting systems in accordance with the Rule 25.11, Texas Administrative Code. The City of Galveston would be responsible for the maintenance and operation of these lights.

The agreement must be accompanied by an ordinance passed by the city and should be executed as soon as possible. Please submit to us two (2) original copies of the agreement, and we will return to you your counterpart once it is executed by our District Engineer.

If you have questions please contact our Transportation Engineer Supervisor, Mr. Gaurang Pandit, at (713) 802-5856 or our District Traffic Engineer, Mr. Sylvester Onwas, at (713) 802-5831.

Sincerely,

Ugonna U. Ughanze, P.E.
Director of Transportation Operations
Houston District

Attachments

cc: Dan Buckley- City of Galveston
Marissa Barnett- City of Galveston
Sylvester E. Onwas, P.E.
Gaurang S. Pandit, P.E.
Mohammadza Molaei, P.E.

OUR VALUES: People • Accountability • Trust • Honesty

OUR MISSION: Connecting You With Texas

An Equal Opportunity Employer

**AGREEMENT FOR CONSTRUCTION, MAINTENANCE
AND OPERATION OF CONTINUOUS HIGHWAY LIGHTING
SYSTEMS WITHIN A MUNICIPALITY
CITY OF GALVESTON**

STATE OF TEXAS §

COUNTY OF TRAVIS §

THIS AGREEMENT, dated this 15 day of JANUARY, 2025, by and between the State of Texas, hereinafter referred to as the "State," party of the first part, acting by and through the Texas Department of Transportation, and the City of Galveston, Galveston County, Texas, acting by and through its duly authorized officers under an ordinance or resolution passed the ___ day of _____, 20___, hereinafter called the "City," party of the second part, is made to become effective when fully executed by both parties.

WITNESSETH

WHEREAS, the City has requested the State to contribute financial aid in the construction, maintenance, and operation of a continuous highway lighting system on freeways and expressways as defined in Section 25.11, Texas Administrative Code. Within the City, said continuous lighting system hereinafter referred to as the "lighting system" is to consist of continuous lighting to be built in sections as financed and designated by the Texas Transportation Commission; and

WHEREAS, the Executive Director, acting for and in behalf of the Texas Transportation Commission, has made it known to the City that the State will construct said highway lighting system, conditioned that the City, as provided in Section 25.11, Texas

Administrative Code and Article 6673b, Vernon's Texas Civil Statutes, will maintain and operate said lighting system.

AGREEMENT

NOW THEREFORE, in consideration of the premises and of the mutual covenants and agreements of the parties hereto to be by them respectively kept and performed as hereinafter set forth, it is agreed as follows:

1. CONSTRUCTION RESPONSIBILITIES

A. The State will prepare or provide for the plans and specifications, advertise for bids, let the construction contract, or otherwise provide for the construction, and will supervise construction, reconstruction, or betterment work as required by said plans and specifications. As a project is developed to construction stage, either as a unit or in increments, the State will submit plans and specifications of the proposed work to the City and will secure the City's consent to construct the lighting system prior to awarding the contract, said City consent to be signified by the signatures of duly authorized City officers in the spaces provided on the title sheet of plans containing the following notation:

“Attachment No. _____ to special AGREEMENT FOR
CONSTRUCTION, MAINTENANCE, AND OPERATION OF
CONTINUOUS HIGHWAY LIGHTING SYSTEMS WITHIN
A MUNICIPALITY, dated _____ .

The City-State construction, maintenance and operation
responsibilities shall be as heretofore agreed to, accepted, and
specified in the Agreement to which these plans are made a part.”

B. All costs of constructing the standard lighting system will be borne by the State. Ornamental poles or other amenities as desired by the City, will be furnished by the City for approval by the State. All work, including work to be done by the representatives of the City, will be in accordance with the National Electric Code and State Standard.

2. MAINTENANCE AND OPERATION RESPONSIBILITIES

A. The City hereby agrees to furnish, at its expense, the electrical energy required for proper operation of the lighting system, such electrical energy to be provided at points on the lighting system as designated by the State. The City further agrees to maintain and operate the lighting system in accordance with the National Electric Code and State standard, in an efficient and sightly condition, including the furnishing of all equipment and labor and making any replacements, which may become necessary, without cost to the State.

B. The City shall assume maintenance and operation on a date to correspond with the date construction of the lighting system is completed and accepted by the State. The State will provide written notification to the City of such acceptance. The City hereby agrees to furnish at its expense the electrical energy consumed by the system during the period of trial operation prior to acceptance by the State. If the lighting system is constructed by sections, this provision shall apply to each such separately constructed section.

C. The City shall obtain approval of the Executive Director before making any major changes in the design and/or operation of the lighting system as designed and constructed by the State or before the removal of any part of the installation except for the purpose of replacement where identical or accepted equivalent equipment to that originally installed is used.

3. GENERAL

A. This Agreement shall remain in force for a period of two years from the date that maintenance and operation responsibilities are first assumed by the City and shall be automatically renewed for two-year periods unless modified by mutual agreement of both parties.

B. The State will not incur any financial obligation to the City as a result of this Agreement.

C. This Agreement may be terminated sixty (60) days after the filing of a written notice by either party of a desire for cancellation. The State reserves the right to remove the lighting system upon cancellation of the Agreement.

D. If, at any time, the City does not maintain and operate the lighting system in a satisfactory manner, the State reserves the right to either arrange for maintenance at the expense of the City or to remove the lighting system. Should the lighting system be removed due to lack of maintenance, the City hereby agrees to reimburse the State for the cost of removal.

E. Should disputes arise as to the parties' obligations under this Agreement, the State's decision shall be final and binding.

F. The City shall comply with all federal, state, and local laws, statutes, ordinances, rules and regulations, and the orders and decrees of any court or administrative bodies or tribunals in any matter affecting the performance of this Agreement.

G. Changes in time frame, character, cost, or obligations authorized herein shall be enacted by written amendment. Any amendment to this Agreement must be executed by both parties within the contract period.

H. This Agreement shall bind and shall be for the sole and exclusive benefit of the respective parties and their legal successors. The City shall not assign or transfer its interest in this Agreement without written consent of the State.

I. In case any one or more of the provisions contained in this Agreement shall, for any reason, be held invalid, illegal, or unenforceable in any respect, such invalidity, illegality or unenforceability shall not affect any other provision thereof, and this Agreement shall be construed as if such invalid, illegal, or unenforceable provision had never been contained herein.

J. This Agreement constitutes the sole and only agreement for lighting at the location described herein of the parties hereto and supersedes any prior understandings or written or oral agreement between the parties respecting the within subject matter.

4. INDEMNIFICATION

The City acknowledges that it is not an agent, servant, or employee of the State and, thus, is responsible for its own acts and deeds and for those of its agents or employees during the performance of the work defined in this Agreement.

IN WITNESS WHEREOF, the parties have thereunto affixed their signatures, the
City of GALVESTON on the ___ day of _____, 20___, and
the Texas Department of Transportation on the 15 day of January, 2025.

ATTEST:

CITY OF: GALVESTON

By: [Signature]

City Manager
(Title of Signing Official)

10/15/24

(Date)

THE STATE OF TEXAS

Executed by and approved for the
Texas Transportation Commission
for the purpose and effect of
activating and/or carrying out the
orders, established policies or work
programs heretofore approved and
authorized by the Texas
Transportation Commission.

APPROVED:

By: [Signature]

District Engineer

Houston District

Date: 1-15-25



City of Galveston

DEPARTMENT OF ENGINEERING

Robert L. Winiecke, P.E., CFM, Director of Infrastructure & Engineering
rwiniecke@galvestontx.gov | Office Number: (409) 797 - 3664 | www.galvestontx.gov

Date: February 27, 2025

To: Brian Maxwell, City Manager
Honorable Mayor and City Council Members

From: Robert L. Winiecke, P.E., CFM, Director of Infrastructure & Engineering

Project Location: Isla Del Sol EST Site

Project: Isla Del Sol Pump Station & 0.5 MG
GST (CIP #W2501)

Request: Consider for approval a professional services contract with Freese & Nichols, Inc. (FNI) to conduct the engineering design of the Isla Del Sol Pump Station & 0.5 MG Ground Storage Tank (GST) project for the City of Galveston in the amount of \$829,688.00; Authorizing the City Manager to execute all necessary documents upon final approval by the City Attorney.

Prior Council Action:

A. There has been no prior City Council action taken on this item.

Current Situation:

- A. The city undertook the development of a new Water Master Plan in 2023 and is working with the consultant towards completing a DRAFT of this report.
- B. During the summer of 2023, Municipal Utilities staff experienced difficulties filling the existing Elevated Storage Tank (EST) at Isla Del Sol during the dry summer months due to customer usage.
- C. Staff had the engineering team preparing the Water Master Plan model the existing system and utilized the observed daily flow data available during this time frame to identify potential engineering solutions to resolve this matter.
- D. Based upon the modeling efforts, the engineering team recommended installing a pump station at the Isla Del Sol site to provide the necessary pumping capacity onsite, to allow for more efficient filling of the existing EST.
- E. The existing EST, at Isla Del Sol, does not have direct pumping capacity located onsite, and therefore its elevation floats based upon system pressure.
- F. During the engineering team's review of the existing water system, they identified that the current feed configuration for the existing EST which is fed directly from the existing water transmission line, does not meet the Texas Commission of Environmental Quality (TCEQ) standards. Therefore, the engineering team recommended that a new Ground Storage Tank (GST) feed tank be installed at this site to provide additional storage for pilling the existing EST utilizing the proposed pump station.
- G. Given recent experience with receiving low bid turnout, navigating high construction costs in an ever-fluctuating heavy civil industry,



and the critical nature of this project, staff believes that it is in the City's best interest to consider delivering this project through the utilization of the Alternative Project Delivery Method known as Construction Manager at Risk (CMAR) as opposed to our traditional delivery methodology of Design-Bid-Build (DBB).

- H. Following is a list of advantages for each party involved in the CMAR process:
 - a. Owners establish a Guaranteed Maximum Price (GMP) for the project, potentially limiting risk during the bidding and construction phase of the project.
 - b. Designers work collaboratively with contractors from an early stage to ensure the feasibility of the design documents.
 - c. Construction managers get to provide input and solicit bids earlier in the project, possibly improving the schedule and budget along the way.
- I. Staff is aware of other communities in our region utilizing CMAR and believes that this project presents a good opportunity for the City to start utilizing this project delivery method.

Fiscal Impact Report:

This project is identified in the FY2025-FY2029 Capital Improvement Plan (CIP) as Project No. W2501, and the following table shows the funding allocation for this project:

Funding Source	Amount
2022 Water CO's	\$829,688.00
Total:	\$829,688.00

Alternatives:

- 1. Approve this request and authorize Staff to begin the engineering design phase of the Isla Del Sol Pump Station & 0.5 MG GST project for the city.
- 2. Instruct Staff to seek out another firm to prepare the engineering design for the city and delay this project.

Staff Recommendation:

Staff recommends approving the professional services contract with FNI to prepare the engineering design for the Isla Del Sol Pump Station & 0.5 MG GST for the City of Galveston.

Respectfully Submitted,



Robert Winiecke, P.E., CFM
Director of Infrastructure and Engineering

Attachments:

Contract # COG-CON-25-____
Pre-Qualified Engineer's List



City of Galveston

DEPARTMENT OF ENGINEERING

Robert L. Winiecke, P.E., CFM, Director of Infrastructure & Engineering
rwiniecke@galvestontx.gov | Office Number: (409) 797-3664 | www.galvestontx.gov

PRE-QUALIFIED ENGINEERING FIRMS*

NO. ¹	FIRM NAME	STREET ¹ / TRAFFIC ²	DRAINAGE	WATER - DISTRIBUTION	WATER - PLANT, STORAGE, PUMPING	SEWER - COLLECTIONS	WASTEWATER - TREATMENT	GEOTECH ¹ / STRUCTURAL ² / FACILITY ³ / ELECTRICAL ⁴	CONST. ENGINEERING MGMT
1	Alliance Geotechnical Group, Inc.							X	
2	Ally General Services, LLC	X ¹²	X						X
3	Alpha Testing, LLC							X	
4	Arceneaux Wilson & Cole, LLC	X ¹²	X	X	X	X	X		X
5	Ardurra Group	X ¹²	X	X	X	X	X	X ²³	X
6	Arredondo, Zepeda & Brunz, LLC	X ¹²	X	X	X	X	X		X
7	Binkley & Barfield, Inc.	X ¹	X	X		X	X		X
8	Blackline Engineering, LLC	X ¹	X	X		X			X
9	CivilTech Engineering, Inc.,	X ¹²	X	X		X		X ²	X
10	CSRS, LLC	X ¹²	X						X
11	Dally + Associates							X ²³	X
12	DE Corp	X ¹	X	X	X	X	X		X
13	Earth Engineering, Inc.							X ¹	
14	EHRA Engineering	X ¹²		X	X	X	X	X ²	X
15	EJES, Inc.	X ¹²	X	X		X		X ¹	X
16	Eustis Engineering, LLC							X ¹	
17	Freese and Nichols, Inc.	X ¹²	X	X	X	X	X	X ³	X
18	GC Engineering, Inc.	X ¹²	X	X		X		X ²	X
19	Halff Associates, Inc.	X ¹²	X	X	X	X	X	X ²³⁴	X
20	HDR Engineering, Inc.	X ¹²	X	X	X	X	X	X ¹²³⁴	X
21	HR Green	X ¹²	X	X	X	X	X		X
22	HT&J, LLC		X						
23	Huitt-Zollars, Inc.	X ¹	X	X		X		X ³	X
24	HVJ Associates, Inc.	X ¹		X	X	X	X	X ¹	X
25	IDS Engineering Group	X ¹	X	X	X	X			
26	Infrastructure Associates, Inc.		X				X		
27	Intercoastal Consultants, LLC		X						
28	Kimley-Horn & Associates, Inc.	X ¹²	X	X	X	X	X		
29	Lockwood, Andrews and Newman	X ¹²	X	X	X	X	X	X ²³⁴	
30	McDonough Engineering Corporation	X ¹	X	X	X	X			X
31	Millennium Engineers Group, inc.							X ¹	
32	Pape-Dawson Engineering, Inc.	X ¹	X			X	X		
33	Professional Service Industries, Inc.							X ¹	
34	Raba Kistner, Inc.							X ¹	
35	Riner Engineering, Inc.							X ¹	
36	RJN Group, Inc.	X ¹		X	X	X			X
37	Stantec Consulting Services, Inc.	X ¹²	X	X	X	X	X	X ¹²³⁴	X
38	T. Baker Smith, LLC	X ¹	X	X	X	X	X	X ²	X
39	Terracon Consultants, LLC							X ¹	
40	Tetra Tech, Inc.			X	X	X	X		
41	The Goodman Corporation	X ¹²							
42	Walter P Moore	X ¹²	X	X	X	X		X ²³	
43	WGI, Inc.	X ¹²	X	X		X		X ¹²⁴	X
44	Zarinkelk Engineering Services, Inc.	X ¹²	X	X		X	X	X ²³	
45	Zero/Six Consulting, LLC							X ³	





City of Galveston

DEPARTMENT OF ENGINEERING

Robert L. Winiecke, P.E., CFM, Director of Infrastructure & Engineering
rwiniecke@galvestontx.gov | Office Number: (409) 797 - 3664 | www.galvestontx.gov

Date: February 27, 2025

To: Brian Maxwell, City Manager
Honorable Mayor and City Council Members

From: Robert L. Winiecke, P.E., CFM, Director of Infrastructure & Engineering

Project Location: Karankawa Beach & Gulf
Palms Subdivisions

Project: Karankawa Beach & Gulf Palms
Drainage Improvements (CIP #D2501)

Request: Consider for approval a professional services contract with Pape-Dawson Engineers (Pape-Dawson) to conduct the engineering design of the Karankawa Beach & Gulf Palms Drainage Improvement project for the City of Galveston in the amount of \$969,555.00; Authorizing the City Manager to execute all necessary documents upon final approval by the City Attorney.

Prior Council Action:

A. There has been no prior City Council action taken on this item.

Current Situation:

- A. The city undertook the development of a new Stormwater Master Plan in 2022 and is working with the Consultant to finalize this report.
- B. The Stormwater Master Plan identifies eighteen (18) problem zones on Galveston Island that exhibit similar drainage characteristics, sewer connectivity, and overland flow drainage area boundaries. These problem zones were developed to understand the physical infrastructure and then identify deficiencies that are potential causes of the flooding issues in the given problem zone.
- C. Problem Zone 6 – Indian Beach was identified in the Stormwater Master Plan which includes the Karankawa Beach & Gulf Palms Subdivisions as an area of concern.
- D. Prior to the Stormwater Master Plan undertaking, through Work Order tracking and prior discussions with residents, Staff was already aware of flooding complaints and drainage issues in these subdivisions.
- E. These two subdivisions are located south of FM3005 and previously drained towards the Gulf facing beaches.
- F. The streets in the Karankawa Beach Subdivision (Habla and Gleis) hold water during rainfall events, high tide events, and tropical events.
- G. In the past, the City's Draining Division regularly dispatched a crew and mobile trash pump to the Karankawa Beach Subdivision to pump water from the roads to reduce the duration of water ponding on the roadways.



- H. The outfall of these subdivisions is located at the northwest corner of the Karankawa Beach Subdivision adjacent to FM3005, and the land in the subdivision is lower than the roadside ditches along FM3005, therefore runoff is unable to evacuate from the neighborhood.
- I. These subdivisions are also served by privately owned and maintained sanitary waste disposal systems (e.g., septic tanks).
- J. The lack of positive drainage in these subdivisions has the potential to reduce the functionality of these waste disposal systems that rely on bacteriological processes and the environment for filtering.

Fiscal Impact Report:

This project is identified in the FY2025-FY2029 Capital Improvement Plan (CIP) as Project No. D2501, and the following table shows the funding allocation for this project:

Funding Source	Amount
IDC	\$969,555.00
Total:	\$969,555.00

Alternatives:

1. Approve this request and authorize Staff to begin the engineering design phase of the Karankawa Beach & Gulf Palms Drainage Improvement project for the city.
2. Instruct Staff to seek out another firm to prepare the engineering design for the city and delay this project.

Staff Recommendation:

Staff recommends approving the professional services contract with Pape-Dawson to prepare the engineering design for the Karankawa Beach & Gulf Palms Drainage Improvements for the City of Galveston.

Respectfully Submitted,

Robert Winiecke, P.E., CFM
 Director of Infrastructure and Engineering

Attachments:

- Contract # COG-CON-25-___
- Problem Zone 6 – Indian Beach description from the DRAFT Stormwater Master Plan Report
- Karankawa Beach & Gulf Palms Drainage Improvements, Project Summary from DRAFT SWMP Report
- Karankawa Beach & Gulf Palms Drainage Improvements, Project Exhibits from DRAFT SWMP Report
- Pre-Qualified Engineer’s List

The area of Problem Zone 4 south of FM 3005 should drain north towards the road and eventually outfall to the West Bay. However, there are raised areas along the southern corridor of FM 3005 that prevent sheet flow from reaching the roadside ditches and cross culverts, so instead flow is redirected south towards the Gulf of Mexico via overland swales and beach access roadways.

In the 5-year storm event, portions of Sandhill Drive, Sunset Bay Drive, and Sea Grass Lane are subject to ponding depth greater than 1.0' and ponding durations greater than 6 hours. The eastern portion of Sandhill Drive experiences ponding depth less than 0.5', and the remaining roads in Problem Zone 4 generally experience ponding less than 0.25'. North of FM 3005, ponding extents are contained to public ROW and low-lying undeveloped areas. South of FM 3005, the ponding extents are not contained to public ROW due to water flowing towards the beach. Several structures have ponding underneath them; however, since the structures are elevated in this area, there is minimal structural risk. These trends continue in the 10-, 25-, and 100-year storm events, with minimal changes in ponding extents but increases in ponding depth and duration for the larger storm events. There are approximately 3 FEMA repetitive loss structures located within Problem Zone 4.

10.5 Problem Zone 5 – Maggie's Cove

Problem Zone 5 is roughly bound by the West Bay on the north, Gulf of Mexico on the south, Kiva Road on the east, and Sunset Bay Drive on the west. Problem Zone 5 is served primarily by roadside ditches along FM 3005 that drain into the bay.

Problem Zone 5 has a topographic high point along FM 3005 that separates the low-lying residential areas to the south, and open space to the north that drains directly to the bay via sheetflow and ditches. The subdivisions south of FM 3005 are restricted by the elevated ridge of FM 3005. While there are culvert crossings that allow the subdivisions to drain north (underneath FM 3005), the existing ditch slopes and grading do not effectively get water to, and through, these culverts.

The subdivisions south of FM 3005 exhibit progressively severe parcel and roadway ponding as storm event return periods increase due to sheetflow being limited by the poor grading of open ditches and the inability for water to drain north. Kahala Beach experiences long duration ponding in the road throughout each storm event and widespread structure flooding. The Dunes of West Beach subdivision also experience long duration road ponding as storm intensity increases. There is minimal development, with public drainage infrastructure, north of FM 3005 for flooding to impact in Problem Zone 5 other than the Seaside Resort private development.

Problem Zone 5 has zero FEMA repetitive loss structures, so structural damages due to flooding does not appear to be a major concern in this area.

10.6 Problem Zone 6 – Indian Beach

Problem Zone 6 is roughly bound by the West Bay on the north, Gulf of Mexico on the south, Jamaica Beach on the east, and Kiva Road on the west. Problem Zone 6 is served primarily by roadside ditches and cross culverts. This area includes the Indian Beach and Karankawa Beach subdivisions. The Karankawa Beach subdivision, located between FM 3005 and the beach, drains north towards the FM 3005 cross culverts via minor roadside ditches.

Due to the low topography and poor grading of the internal drainage systems within the Karankawa Beach neighborhood, water is unable to fully drain across FM 3005. While there are culverts intended to drain this area, the 5-year storm event shows ponding well outside of the public ROW along Habla Drive and Bristow Drive. This area is known to have flooding issues that cause significant impacts to the residents' ability to access their properties.

Indian Beach consists of minor roadside ditches connected via driveway culverts that meander towards the West Bay. A portion of the Indian Beach subdivision is located south of FM 3005 and experiences similar deficiencies as Karankawa Beach, with the exception that long duration ponding following intense storm events. West De Vaca Lane and East De Vaca Lane experience significant ponding for all storm events due to the insufficient capacity and poor grading of the systems connected through FM 3005. The portion of Indian Beach north of FM 3005 does not experience significant roadway flooding for the 5-year storm, with most ponding being in low-lying open spaces with no structures.

The 100-year storm event causes significant flooding impacts to the subdivisions south of FM 3005, with widespread roadway and parcel ponding that exceeds 1.0'. Additionally, the 100-year storm event begins to cause roadway flooding in the northern section of Indian Beach along Warrior Court and Kiva Road. Shallow ponding outside of the public ROW is present across most of Problem Zone 6, with occasional damage possible to structures that are not significantly elevated. There are approximately 12 FEMA repetitive loss structures located within Problem Zone 6.

10.7 Problem Zone 7 – Galveston Country Club (Lake Como)

Problem Zone 7 is roughly bound by the West Bay on the north, FM 3005 on the south, Pabst Road on the east, and Jamaica Beach on the west. Problem Zone 7 is served primarily by roadside ditches and natural, meandering channels that drain directly north towards the West Bay through a series of wetlands, coves, lakes, and bayous. Residential subdivisions around the Galveston Country Club drain directly off elevated roadway centerlines to roadside ditch systems that carry flow to their respective outfalls into the West Bay. In some instances, runoff drains directly off roadways, through residential properties, and directly into Lake Como, Delehide Cove, or Eckert Bayou. Some of the primary subdivisions located in Problem Zone 7 are Pirate's Cove, Lafitte's Cove, and Palm Beach. The Galveston Island State Park is located along the western side of Problem Zone 7 and is made up of mainly undeveloped land with several narrow, developed ditches to convey water away from FM 3005.

Approximately 12 separate culvert crossings convey offsite flow from south of FM 3005 (Problem Zone 8) to Problem Zone 7. This flow is discharged either directly into the undeveloped land of Galveston Island State Park or into the ditches located along the northern ROW of FM 3005.

The 5-year storm event does not significantly impact Problem Zone 7 with flooding issues beyond localized roadway ponding along Eckert Drive, and Stewart Road between El Lago Street and Pirates Beach Circle.

The 100-year storm event causes widespread flooding issues along, and around, Stewart Road between 12 Mile Road and 13 Mile Road. Depths exceed 1.0' along Stewart Road and shallow ponding extends outside of the public ROW onto residential properties; however, the risk of structural flooding in Problem Zone 7 is generally low relative to other parts of the City. There are approximately four FEMA repetitive loss structures located within Problem Zone 7. Roadway ponding depth along El Lago Street, Las Palmas Street, Marina Boulevard, and Pirates Beach Circle exceed 2.0' along the full span of those streets from Stewart Road near FM 3005, resulting in significant mobility impacts to the area.

10.8 Problem Zone 8 – Pirates Beach

Problem Zone 8 is roughly bound by the West Bay on the northeast and FM 3005 on the northwest, Gulf of Mexico on the south, Millie's Road on the east, and Jamaica Beach on the west. South of FM 3005, Problem Zone 8 includes Galveston State Park and the Pirate's Beach, Bermuda Beach, and Spanish Grant subdivisions which are all served fully by roadside ditches and minor cross culverts that drain directly to FM 3005. North of

15.3.4 Karankawa Beach and Gulf Palms Subdivisions

15.3.4.1 Area of Influence

For the Karankawa Beach and Gulf Palms subdivisions, the area of influence covers Problem Zone 6 and is roughly bound by Termini San Luis Pass Road on the north, the Gulf of Mexico on the south, 16 Mile Road on the east, and Antigua Drive on the west. The modeled area of influence for the Karankawa Beach & Gulf Palms Subdivision improvement is shown on **Exhibit 448**.

15.3.4.2 Baseline Conditions

Existing Drainage Infrastructure

The existing Karankawa Beach & Gulf Palms subdivisions’ drainage system consists of small diameter driveway culverts directing water north into the roadside ditch along FM 3005 to ultimately drain into the Bay.

System Deficiencies

The Karankawa Beach and Gulf Palms drainage system only consists of driveway culverts draining into FM 3005’s roadside ditch causing extended duration roadway flooding and occasional structural flooding. The Karankawa Beach and Gulf Palms drainage system improvements are intended to target the identified damage center for the Karankawa Beach & Gulf Palms area.

Within Karankawa Beach and Gulf Palms, areas along Glei Street and Bristow Drive have poorly graded, maintained, and missing ditches and culverts. The sedimentation and clogging exacerbate ponding along Glei Street, Habla Street, Bristow Drive, and 16 Mile Rd. FM 3005’s roadside ditch and elevation limits drainage to the north causing extensive flooding duration.

Performance Metrics

Table 44 contains the performance metrics for each storm event for Karankawa Beach & Gulf Palms Subdivision.

Table 44. Baseline Performance Metrics – Karankawa Beach & Gulf Palms Subdivision

Recurrence Interval	Parcels	Roadway Ponding (miles)		Number of Intersections		Number of Structures
	< 1 acre & > 50% Ponded	Depth (above 6")	Duration (> 3hrs)	Depth (above 6")	Duration (> 3hrs)	Depth (above 6")
5-Year	35	0	0	2	2	12
10-Year	44	0	0	2	2	15
25-Year	51	0	0	4	2	17
100-Year	65	0	0	5	4	25
Total in AOI	143	1		5		99

15.3.4.3 Project Description

The Karankawa Beach and Gulf Palms drainage improvements involve the deepening and re-grading of existing roadside ditches within both subdivisions and along FM 3005, an improved outfall channel west of Kiva Road, new storm sewer along FM 3005, Antigua Drive, Habla Drive, Bristow Drive, and 16 Mile Road, and a pump associated with the FM 3005 cross culvert between Antigua Drive and Habla Drive. The pump will allow water in the two subdivisions to drain north across FM 3005 and west towards the outfall channel. The project also involves the replacement of water and sewer lines impacted by the improved ditches and new storm sewer. As shown on **Exhibit 448**, the Karankawa Beach & Gulf Palms drainage improvements include approximately:

- 13,700 linear feet of roadside ditch re-grading
- 2,100 linear feet of open channel widening.
- 7,600 linear feet of storm sewer ranging from 3’x2’ RCB to 9’x5’ RCB
- 31 culvert crossings

An alternative configuration for this improvement was considered which would shorten the overall distance from the Karankawa Beach subdivision. However, ROW acquisition would be required as the alternative alignment would need to extend directly north from FM 3005 to a new outfall into the Bay. The proposed alignment stays mostly within publicly-owned ROW and does not require substantial ROW acquisition.

15.3.4.4 Phasing Considerations

The Karankawa Beach and Gulf Palms drainage improvements do not require phasing with other proposed improvements. However, if the limits of the improvements developed in this master plan are subdivided into smaller project phases, it is recommended to start at the storm sewer or ditch outfalls and work upstream.

15.3.4.5 Proposed Performance Metrics

Table 45 contains the proposed depth and duration reductions for the performance metrics of all storm events for Karankawa Beach and Gulf Palms Subdivision. **Exhibits 449-471** show the corresponding layout of these benefits for all evaluated storm events and associated performance metrics. The percent reductions represent the share of the respective infrastructure and metric that is brought below the measured threshold from baseline to proposed conditions within the project area of influence. For example, 56% of roadway miles that experienced a flood depth above 6 inches within the AOI under 10-year baseline conditions have been reduced to a depth below 6 inches under the 10-year proposed conditions. The proposed performance metrics are intended to quantify project benefits and allow for the prioritization and scoring of all capital projects outlined in this plan.

Table 45. Proposed Performance Metrics Reductions – Karankawa Beach and Gulf Palms Subdivision

Recurrence Interval	Scoring Weight					
	15%	20%	5%	25%	10%	25%
	Parcels	Roadway Ponding (miles)		Number of Intersections		Number of Structures
	< 1 acre & > 50% Ponded	Depth (above 6")	Duration (> 3hrs)	Depth (above 6")	Duration (> 3hrs)	Depth (above 6")
5-Year	54%	46%	46%	0%	0%	67%
10-Year	55%	56%	53%	0%	0%	67%
25-Year	37%	41%	56%	0%	0%	59%
100-Year	35%	36%	44%	0%	25%	56%

15.3.4.6 Cost Estimate

An opinion of probable construction cost (OPCC) was developed for the Karankawa Beach and Gulf Palms Subdivision Improvement Project. The individual items included in the cost estimates can be found in **Appendix J**. A summary of the OPCC estimates are shown below in **Table 46**.

Table 46. Cost Estimate – Karankawa Beach & Gulf Palms Subdivision

Easements & ROW	Engineering & Design	Construction	Construction Contingency	Constr. Mgmt & Testing	Grant Administration	Total Cost (2024):
\$143,000	\$850,000	\$4,250,000	\$1,276,000	\$567,000	\$0	\$7,086,000

15.3.4.7 Benefit-Cost Analysis

A benefit cost analysis (BCA) was performed to quantify the economic impacts from structural flood damages for the 5-year, 10-year, 25-year, and 100-year design storm event within the project’s area of influence. Existing and proposed damages were calculated and annualized to determine the economic benefit provided by the proposed improvements for each design storm event. Annualization of damages refers to applying different weights to each design storm’s calculated damages based on the probability of a given storm’s chance of occurring in any given year. The annualized damage reduction value (benefit) and annualized cost value are utilized to generate the project’s benefit-cost ratio (BCR).

Social benefits were calculated based on the magnitude of residents that live and work within the project’s area of influence. As outlined by FEMA, social benefits refer to the dollar value attributed to the mental stress and anxiety of all impacted residents and the lost wages and productivity of all impacted workers that are benefitted by the proposed improvement. **Table 47** shows the social and structural benefits, project cost, and resulting BCR.

Table 47. Benefit-Cost Analysis – Karankawa Beach & Gulf Palms Subdivision

Social Benefits	Structural Benefits	Project Cost	BCR
\$15,467	\$1,507,258	\$7,086,000	0.21

The detailed BCA process is shown in **Appendix K** and calculates a BCR of 0.21 for the Karankawa Beach & Gulf Palms Subdivision drainage improvement project. A BCR lower than 0.5 indicates that the project is not cost-effective, and it should be expected that the City will be responsible for the full cost without partners unless funding opportunities are identified without minimum BCR requirements.

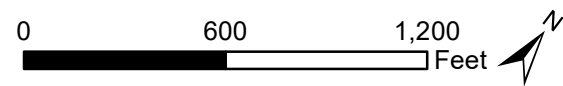
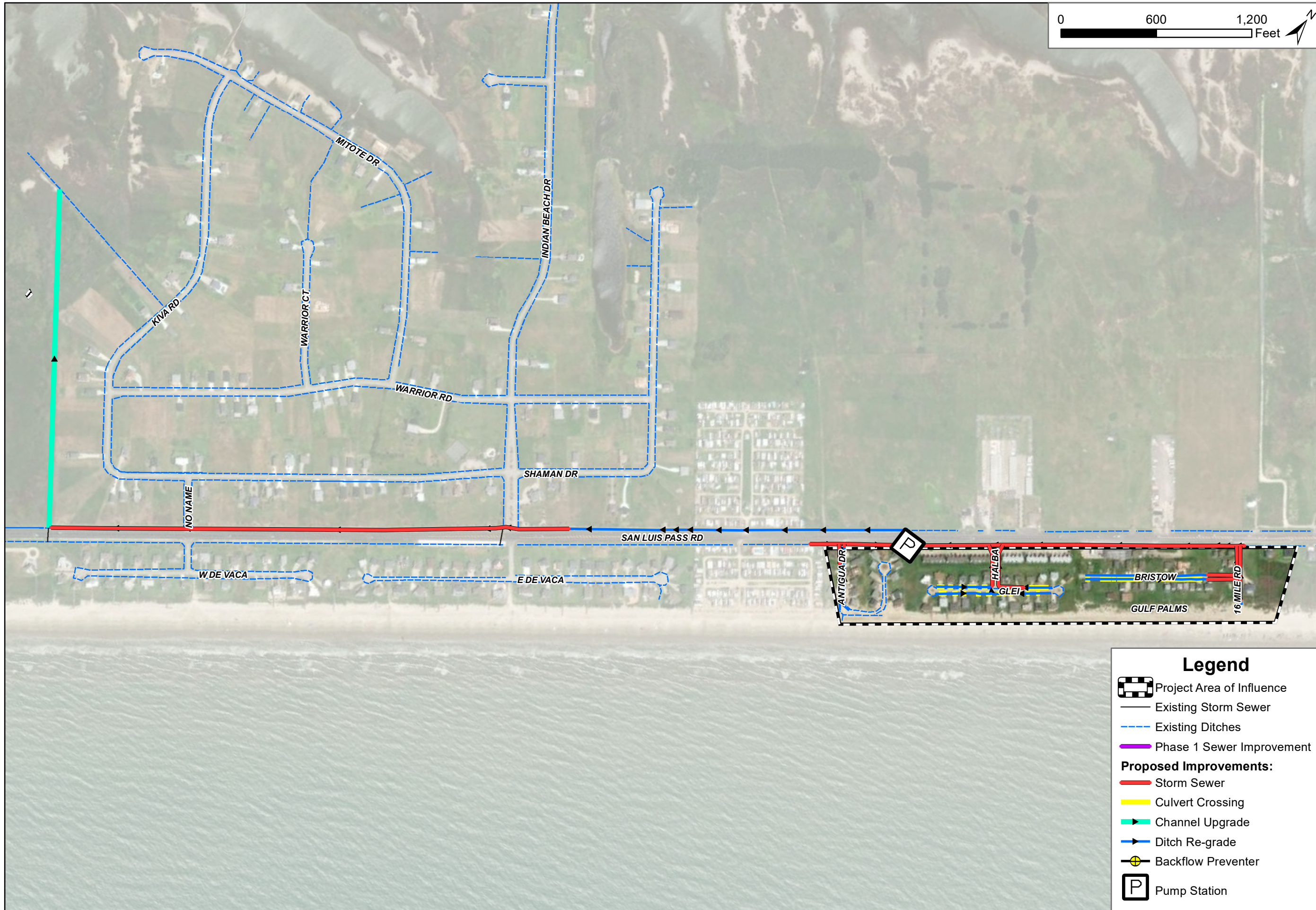

CITY OF GALVESTON
STORMWATER MASTER PLAN (SWMP)
KARANKAWA BEACH & GULF PALMS
PROPOSED DRAINAGE IMPROVEMENT PROJECT
SCHEMATIC LAYOUT

PREPARED: JKB	CHECKED: AEP	APPROVED: MJM
---------------	--------------	---------------



DATE: JAN 2024
 SCALE: AS NOTED

EXHIBIT 448

- Legend**
- Project Area of Influence
 - Existing Storm Sewer
 - Existing Ditches
 - Phase 1 Sewer Improvement
 - Proposed Improvements:**
 - Storm Sewer
 - Culvert Crossing
 - Channel Upgrade
 - Ditch Re-grade
 - Backflow Preventer
 - Pump Station

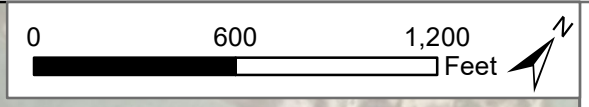

CITY OF GALVESTON
 STORMWATER MASTER PLAN (SWMP)
 KARANKAWA BEACH & GULF PALMS
 PROPOSED DRAINAGE IMPROVEMENT PROJECT
 5-YEAR PONDING REDUCTION

PREPARED: JKB
 CHECKED: AEP
 APPROVED: MJM

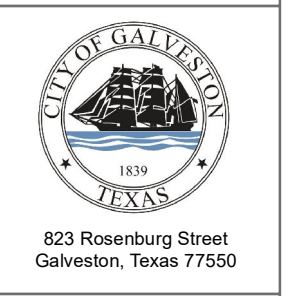

DATE: JAN 2024
 SCALE: AS NOTED

EXHIBIT 449

Legend

Project Area of Influence	Existing 5-Year Ponding Depth	Proposed 5-Year Ponding Depth
Phase 1 Sewer Improvement	0.25' - 0.5'	0.25' - 0.5'
Proposed Improvements:	0.5' - 0.75'	0.5' - 0.75'
Storm Sewer/Culvert	0.75' - 1.0'	0.75' - 1.0'
Open Ditch/Channel	1.0' - 2.0'	1.0' - 2.0'
Pump Station	2.0' - 3.0'	2.0' - 3.0'
	> 3.0'	> 3.0'

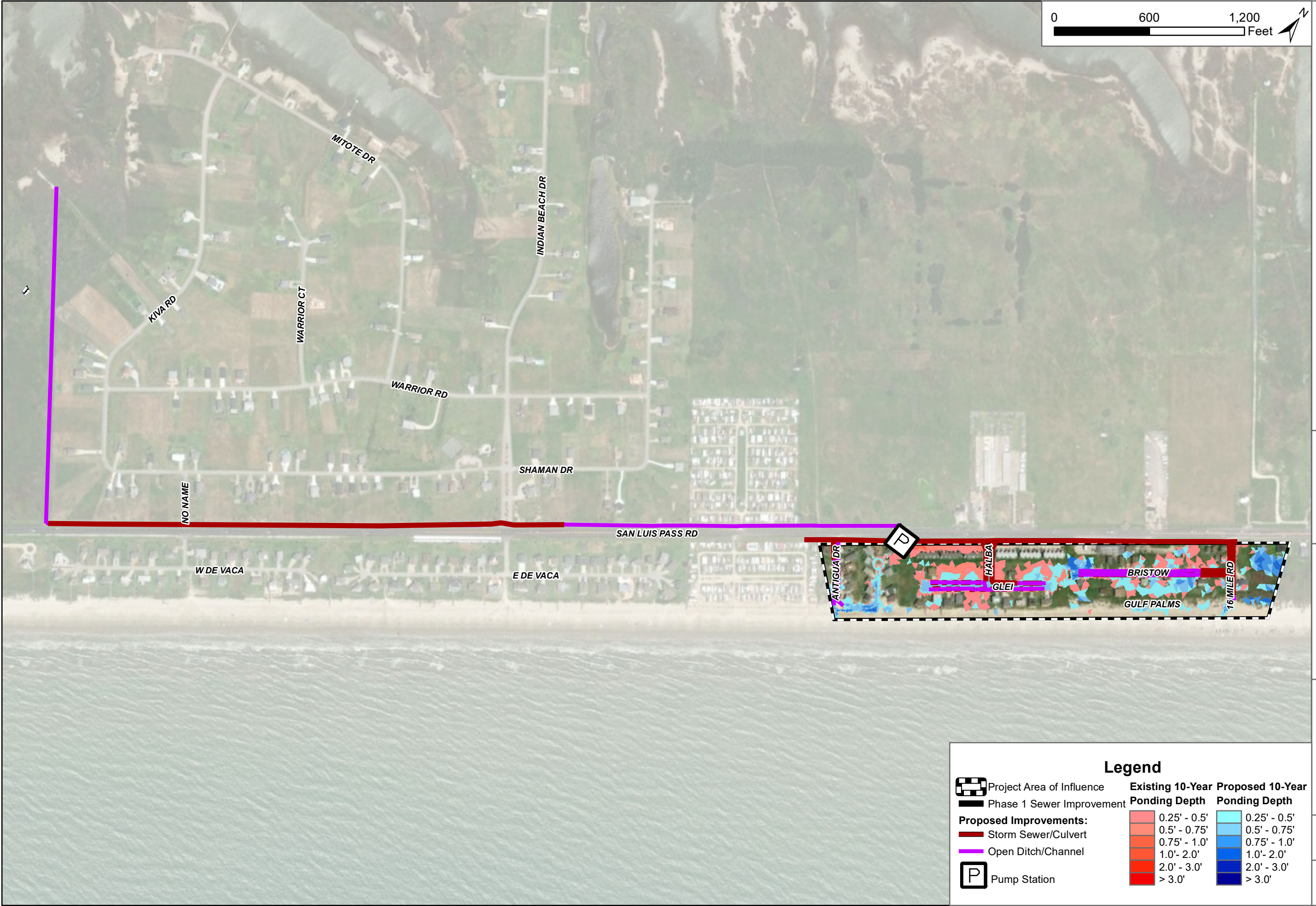
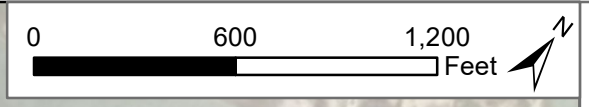

CITY OF GALVESTON
 STORMWATER MASTER PLAN (SWMP)
 KARANKAWA BEACH & GULF PALMS
 PROPOSED DRAINAGE IMPROVEMENT PROJECT
 10-YEAR PONDING REDUCTION

PREPARED: JKB
 CHECKED: AEP
 APPROVED: MJM



823 Rosenberg Street
 Galveston, Texas 77550

DATE: JAN 2024
 SCALE: AS NOTED

EXHIBIT 450

Legend

Project Area of Influence	Existing 10-Year Ponding Depth	Proposed 10-Year Ponding Depth
Phase 1 Sewer Improvement	0.25' - 0.5'	0.25' - 0.5'
Storm Sewer/Culvert	0.5' - 0.75'	0.5' - 0.75'
Open Ditch/Channel	0.75' - 1.0'	0.75' - 1.0'
Pump Station	1.0' - 2.0'	1.0' - 2.0'
	2.0' - 3.0'	2.0' - 3.0'
	> 3.0'	> 3.0'

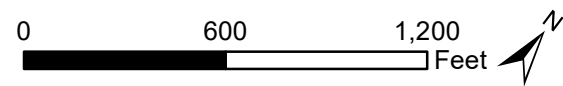

CITY OF GALVESTON
STORMWATER MASTER PLAN (SWMP)
KARANKAWA BEACH & GULF PALMS
PROPOSED DRAINAGE IMPROVEMENT PROJECT
25-YEAR PONDING REDUCTION

PREPARED: JKB
 CHECKED: AEP
 APPROVED: MJM



DATE: JAN 2024
 SCALE: AS NOTED

EXHIBIT 451

Legend

Project Area of Influence	Existing 25-Year Ponding Depth	Proposed 25-Year Ponding Depth
Phase 1 Sewer Improvement	0.25' - 0.5'	0.25' - 0.5'
Proposed Improvements:	0.5' - 0.75'	0.5' - 0.75'
Storm Sewer/Culvert	0.75' - 1.0'	0.75' - 1.0'
Open Ditch/Channel	1.0' - 2.0'	1.0' - 2.0'
Pump Station	2.0' - 3.0'	2.0' - 3.0'
	> 3.0'	> 3.0'

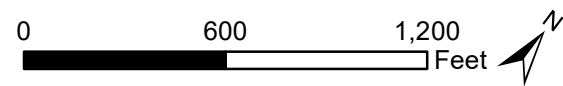

**CITY OF GALVESTON
STORMWATER MASTER PLAN (SWMP)**

**KARANKAWA BEACH & GULF PALMS
PROPOSED DRAINAGE IMPROVEMENT PROJECT
100-YEAR PONDING REDUCTION**

PREPARED: JKB	CHECKED: AEP	APPROVED: MJM
---------------	--------------	---------------



DATE: JAN 2024
SCALE: AS NOTED

EXHIBIT 452

Legend		
	Project Area of Influence	
	Phase 1 Sewer Improvement	
Proposed Improvements:		
	Storm Sewer/Culvert	
	Open Ditch/Channel	
	Pump Station	
Existing 100-Year Ponding Depth		
	0.25' - 0.5'	
	0.5' - 0.75'	
	0.75' - 1.0'	
	1.0' - 2.0'	
	2.0' - 3.0'	
> 3.0' color swatch"/>	> 3.0'	
Proposed 100-Year Ponding Depth		
	0.25' - 0.5'	
	0.5' - 0.75'	
	0.75' - 1.0'	
	1.0' - 2.0'	
	2.0' - 3.0'	
	> 3.0'	

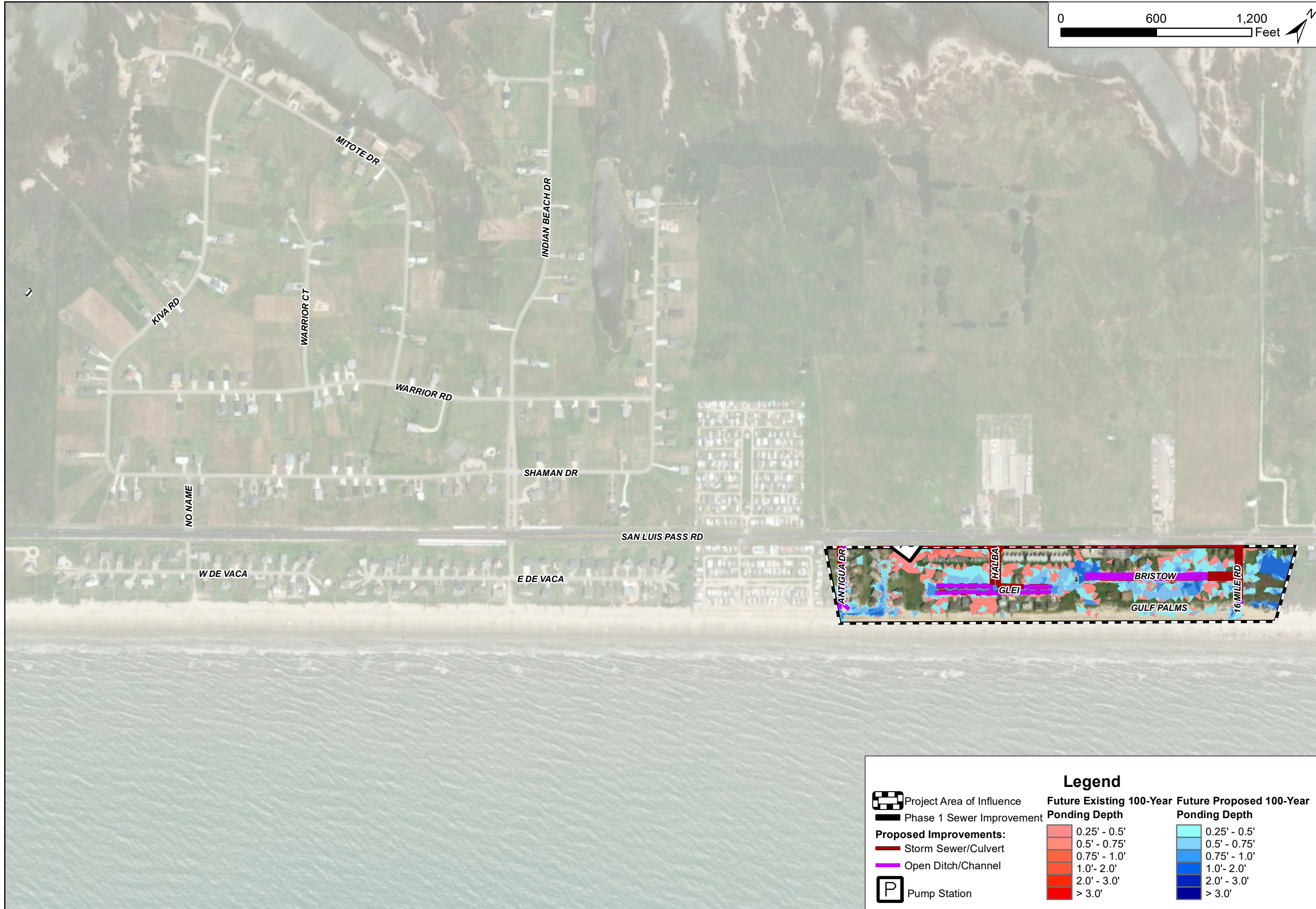

CITY OF GALVESTON
 STORMWATER MASTER PLAN (SWMP)
 KARANKAWA BEACH & GULF PALMS
 PROPOSED DRAINAGE IMPROVEMENT PROJECT
 FUTURE 100-YEAR PONDING REDUCTION

PREPARED: JKB
 CHECKED: AEP
 APPROVED: MJM



DATE: JAN 2024
 SCALE: AS NOTED

EXHIBIT 453

Legend

Project Area of Influence	Future Existing 100-Year Ponding Depth	Future Proposed 100-Year Ponding Depth
Phase 1 Sewer Improvement	0.25' - 0.5'	0.25' - 0.5'
Proposed Improvements:	0.5' - 0.75'	0.5' - 0.75'
Storm Sewer/Culvert	0.75' - 1.0'	0.75' - 1.0'
Open Ditch/Channel	1.0' - 2.0'	1.0' - 2.0'
Pump Station	2.0' - 3.0'	2.0' - 3.0'
	> 3.0'	> 3.0'



**CITY OF GALVESTON
STORMWATER MASTER PLAN (SWMP)**

**KARANKAWA BEACH & GULF PALMS
PROPOSED DRAINAGE IMPROVEMENT PROJECT
5-YEAR DEPTH REDUCTION**

PREPARED: JKB
CHECKED: AEP
APPROVED: MJM

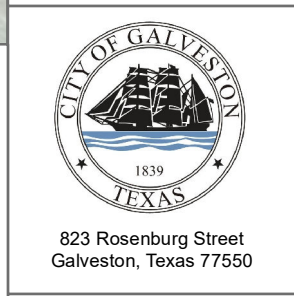

DATE: JAN 2024
SCALE: AS NOTED

EXHIBIT 454

Legend

- Project Area of Influence
- Phase 1 Sewer Improvement
- Proposed Improvements:**
 - Storm Sewer/Culvert
 - Open Ditch/Channel
- Pump Station
- Depth Reduction Point

5-Year Ponding Depth Reduction

- < 0.1'
- 0.1' - 0.25'
- 0.25' - 0.50'
- 0.50' - 0.75'
- 0.75' - 1.0'
- > 1.0'



CITY OF GALVESTON
 STORMWATER MASTER PLAN (SWMP)
 KARANKAWA BEACH & GULF PALMS
 PROPOSED DRAINAGE IMPROVEMENT PROJECT
 10-YEAR DEPTH REDUCTION

PREPARED: JKB
 CHECKED: AEP
 APPROVED: MJM

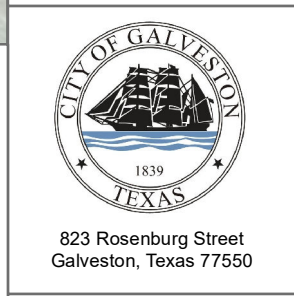

DATE: JAN 2024
 SCALE: AS NOTED

EXHIBIT 455

Legend

- Project Area of Influence
- Phase 1 Sewer Improvement
- Proposed Improvements:**
 - Storm Sewer/Culvert
 - Open Ditch/Channel
- Pump Station
- Depth Reduction Point

10-Year Ponding Depth Reduction

- < 0.1'
- 0.1' - 0.25'
- 0.25' - 0.50'
- 0.50' - 0.75'
- 0.75' - 1.0'
- > 1.0'



CITY OF GALVESTON
 STORMWATER MASTER PLAN (SWMP)
 KARANKAWA BEACH & GULF PALMS
 PROPOSED DRAINAGE IMPROVEMENT PROJECT
 25-YEAR DEPTH REDUCTION

PREPARED: JKB
 CHECKED: AEP
 APPROVED: MJM



823 Rosenberg Street
 Galveston, Texas 77550

DATE: JAN 2024
 SCALE: AS NOTED

EXHIBIT 456

Legend

- Project Area of Influence
- Phase 1 Sewer Improvement
- Proposed Improvements:**
 - Storm Sewer/Culvert
 - Open Ditch/Channel
- Pump Station
- Depth Reduction Point

25-Year Ponding Depth Reduction

- < 0.1'
- 0.1' - 0.25'
- 0.25' - 0.50'
- 0.50' - 0.75'
- 0.75' - 1.0'
- > 1.0'



CITY OF GALVESTON
STORMWATER MASTER PLAN (SWMP)
 KARANKAWA BEACH & GULF PALMS
 PROPOSED DRAINAGE IMPROVEMENT PROJECT
 100-YEAR DEPTH REDUCTION

PREPARED: JKB
 CHECKED: AEP
 APPROVED: MJM



823 Rosenberg Street
 Galveston, Texas 77550

DATE: JAN 2024
 SCALE: AS NOTED

EXHIBIT 457

Legend

Project Area of Influence	100-Year Ponding Depth Reduction
Phase 1 Sewer Improvement	
Proposed Improvements:	
Storm Sewer/Culvert	< 0.1'
Open Ditch/Channel	0.1' - 0.25'
Pump Station	0.25' - 0.50'
Depth Reduction Point	0.50' - 0.75'
	0.75' - 1.0'
	> 1.0'



CITY OF GALVESTON
 STORMWATER MASTER PLAN (SWMP)
 KARANKAWA BEACH & GULF PALMS
 PROPOSED DRAINAGE IMPROVEMENT PROJECT
 FUTURE 100-YEAR DEPTH REDUCTION

PREPARED: JKB
 CHECKED: AEP
 APPROVED: MJM

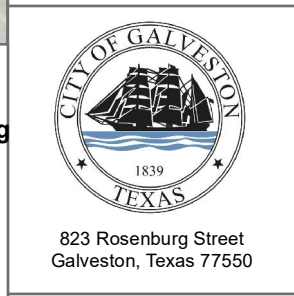

DATE: JAN 2024
 SCALE: AS NOTED

EXHIBIT 458

Legend

- Project Area of Influence
- Phase 1 Sewer Improvement
- Proposed Improvements:**
 - Storm Sewer/Culvert
 - Open Ditch/Channel
- Pump Station
- Depth Reduction Point

Future 100-Year Ponding Depth Reduction

- < 0.1'
- 0.1' - 0.25'
- 0.25' - 0.50'
- 0.50' - 0.75'
- 0.75' - 1.0'
- > 1.0'



CITY OF GALVESTON
 STORMWATER MASTER PLAN (SWMP)
 KARANKAWA BEACH & GULF PALMS
 PROPOSED DRAINAGE IMPROVEMENT PROJECT
 5-YEAR DURATION REDUCTION

PREPARED: JKB
 CHECKED: AEP
 APPROVED: MJM



823 Rosenberg Street
 Galveston, Texas 77550

DATE: JAN 2024
 SCALE: AS NOTED

EXHIBIT 459

Legend

- Project Area of Influence
- Phase 1 Sewer Improvement
- Proposed Improvements:**
 - Storm Sewer/Culvert
 - Open Ditch/Channel
- Pump Station
- Duration Reduction Point

5-Year Ponding Duration Reduction

- < 0.1 hr
- 0.1 - 1.0 hr
- 1.0 - 2.0 hrs
- 2.0 - 4.0 hrs
- 4.0 - 6.0 hrs
- > 6.0 hrs

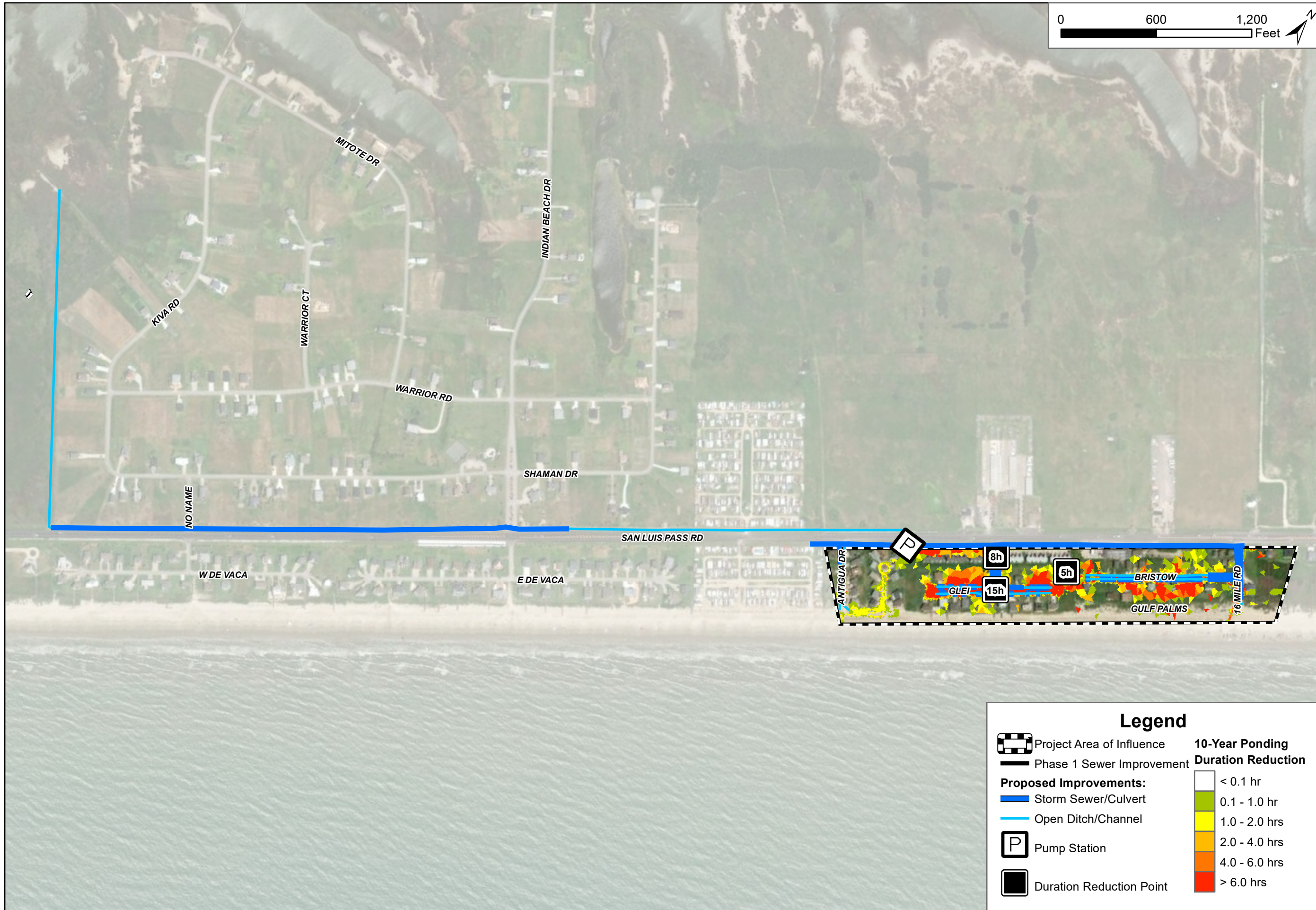

CITY OF GALVESTON
 STORMWATER MASTER PLAN (SWMP)
 KARANKAWA BEACH & GULF PALMS
 PROPOSED DRAINAGE IMPROVEMENT PROJECT
 10-YEAR DURATION REDUCTION

PREPARED: JKB
 CHECKED: AEP
 APPROVED: MJM



823 Rosenberg Street
 Galveston, Texas 77550

DATE: JAN 2024
 SCALE: AS NOTED

EXHIBIT 460

Legend

- Project Area of Influence
- Phase 1 Sewer Improvement
- Proposed Improvements:**
 - Storm Sewer/Culvert
 - Open Ditch/Channel
- Pump Station
- Duration Reduction Point

10-Year Ponding Duration Reduction

- < 0.1 hr
- 0.1 - 1.0 hr
- 1.0 - 2.0 hrs
- 2.0 - 4.0 hrs
- 4.0 - 6.0 hrs
- > 6.0 hrs

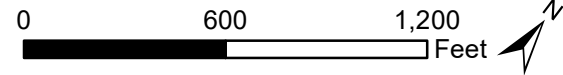

CITY OF GALVESTON
STORMWATER MASTER PLAN (SWMP)
 KARANKAWA BEACH & GULF PALMS
 PROPOSED DRAINAGE IMPROVEMENT PROJECT
 25-YEAR DURATION REDUCTION

PREPARED: JKB	CHECKED: AEP	APPROVED: MJM
---------------	--------------	---------------



DATE: JAN 2024
 SCALE: AS NOTED

EXHIBIT 461

Legend

Project Area of Influence	25-Year Ponding Duration Reduction
Phase 1 Sewer Improvement	
Proposed Improvements:	
Storm Sewer/Culvert	< 0.1 hr
Open Ditch/Channel	0.1 - 1.0 hr
Pump Station	1.0 - 2.0 hrs
Duration Reduction Point	2.0 - 4.0 hrs
	4.0 - 6.0 hrs
	> 6.0 hrs

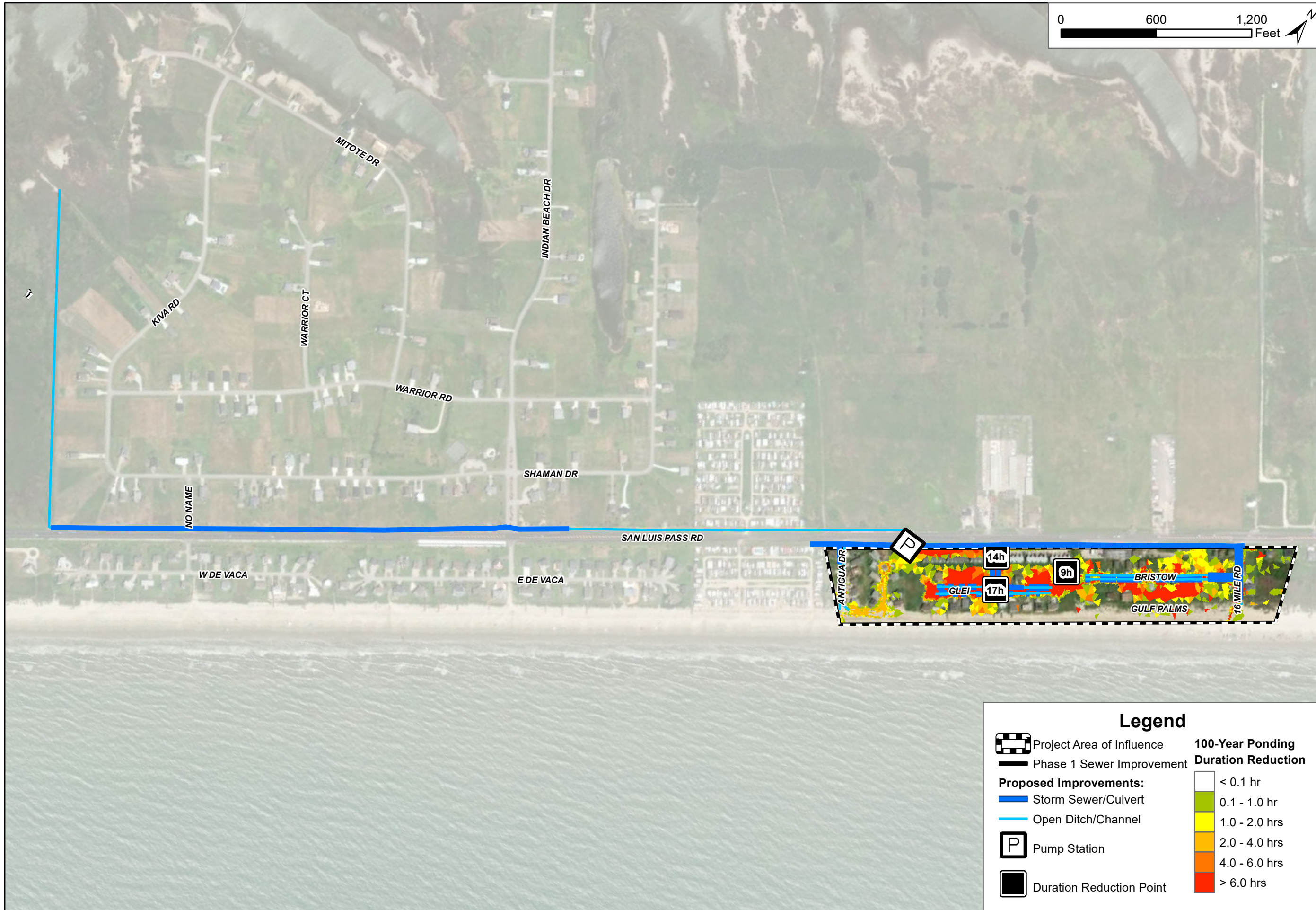

CITY OF GALVESTON
 STORMWATER MASTER PLAN (SWMP)
 KARANKAWA BEACH & GULF PALMS
 PROPOSED DRAINAGE IMPROVEMENT PROJECT
 100-YEAR DURATION REDUCTION

PREPARED: JKB
 CHECKED: AEP
 APPROVED: MJM

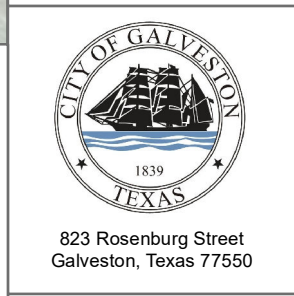

DATE: JAN 2024
 SCALE: AS NOTED

EXHIBIT 462

Legend

- Project Area of Influence
- Phase 1 Sewer Improvement
- Proposed Improvements:**
 - Storm Sewer/Culvert
 - Open Ditch/Channel
- Pump Station
- Duration Reduction Point

100-Year Ponding Duration Reduction

- < 0.1 hr
- 0.1 - 1.0 hr
- 1.0 - 2.0 hrs
- 2.0 - 4.0 hrs
- 4.0 - 6.0 hrs
- > 6.0 hrs

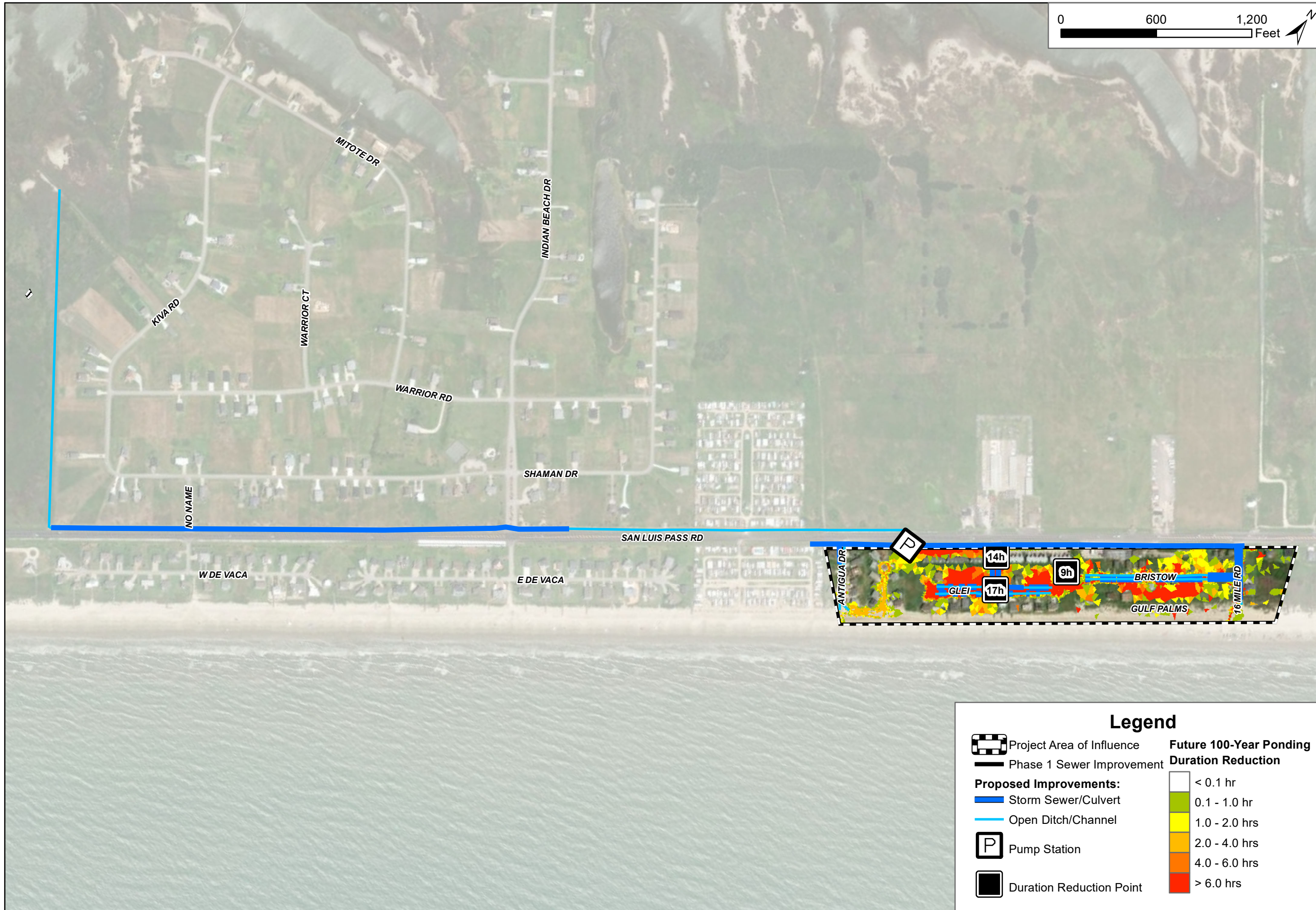

CITY OF GALVESTON
 STORMWATER MASTER PLAN (SWMP)
 KARANKAWA BEACH & GULF PALMS
 PROPOSED DRAINAGE IMPROVEMENT PROJECT
 FUTURE 100-YEAR DURATION REDUCTION

PREPARED: JKB
 CHECKED: AEP
 APPROVED: MJM



823 Rosenberg Street
 Galveston, Texas 77550

DATE: JAN 2024
 SCALE: AS NOTED

EXHIBIT 463

Legend

Project Area of Influence	Future 100-Year Ponding Duration Reduction
Phase 1 Sewer Improvement	< 0.1 hr
Proposed Improvements:	0.1 - 1.0 hr
Storm Sewer/Culvert	1.0 - 2.0 hrs
Open Ditch/Channel	2.0 - 4.0 hrs
Pump Station	4.0 - 6.0 hrs
Duration Reduction Point	> 6.0 hrs

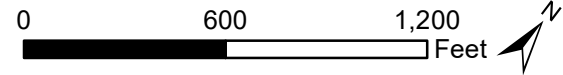

CITY OF GALVESTON
STORMWATER MASTER PLAN (SWMP)
 KARANKAWA BEACH & GULF PALMS
 DRAINAGE IMPROVEMENT PROJECT
 5-YEAR ROADWAY BENEFIT METRICS

PREPARED: JKB
 CHECKED: AEP
 APPROVED: MJM



823 Rosenberg Street
 Galveston, Texas 77550

DATE: JAN 2024
 SCALE: AS NOTED

EXHIBIT 464

Legend

Project Area of Influence

Ponded Intersections (> 0.5')

- Existing
- Removed

Ponded Roadway (> 0.5')

- Existing
- Removed

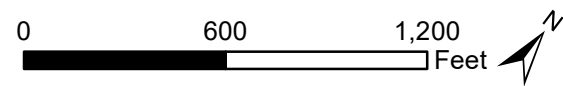

CITY OF GALVESTON
STORMWATER MASTER PLAN (SWMP)
 KARANKAWA BEACH & GULF PALMS
 PROPOSED DRAINAGE IMPROVEMENT PROJECT
 10-YEAR ROADWAY BENEFIT METRICS

PREPARED: JKB
CHECKED: AEP
APPROVED: MJM

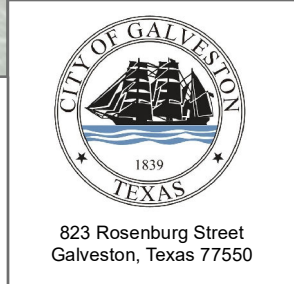

DATE: JAN 2024
 SCALE: AS NOTED

EXHIBIT 465

Legend

Project Area of Influence

Pondered Intersections (> 0.5')

- Existing
- Removed

Pondered Roadway (> 0.5')

- Existing
- Removed

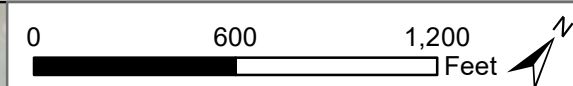

CITY OF GALVESTON
STORMWATER MASTER PLAN (SWMP)
 KARANKAWA BEACH & GULF PALMS
 PROPOSED DRAINAGE IMPROVEMENT PROJECT
 25-YEAR ROADWAY BENEFIT METRICS

PREPARED: JKB
 CHECKED: AEP
 APPROVED: MJM



823 Rosenberg Street
 Galveston, Texas 77550

DATE: JAN 2024
 SCALE: AS NOTED

EXHIBIT 466

Legend

- Project Area of Influence
- Ponded Intersections (> 0.5')**
- Existing
- Removed
- Ponded Roadway (> 0.5')**
- Existing
- Removed

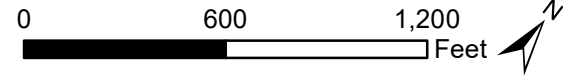

CITY OF GALVESTON
STORMWATER MASTER PLAN (SWMP)
 KARANKAWA BEACH & GULF PALMS
 PROPOSED DRAINAGE IMPROVEMENT PROJECT
 100-YEAR ROADWAY BENEFIT METRICS

PREPARED: JKB
 CHECKED: AEP
 APPROVED: MJM

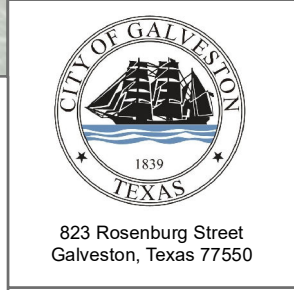

DATE: JAN 2024
 SCALE: AS NOTED

EXHIBIT 467

Legend

Project Area of Influence

Ponded Intersections (> 0.5')

- Existing
- Removed

Ponded Roadway (> 0.5')

- Existing
- Removed



Legend

Project Area of Influence

Structure Flood Depth (> 0.5')

- Existing
- Removed

Flooded Parcel Area (> 50%)

- Existing
- Removed

CITY OF GALVESTON
STORMWATER MASTER PLAN (SWMP)

KARANKAWA BEACH & GULF PALMS
 DRAINAGE IMPROVEMENT PROJECT
 5-YEAR STRUCTURE & PARCEL BENEFIT METRICS

PREPARED: JKB
 CHECKED: AEP
 APPROVED: MJM

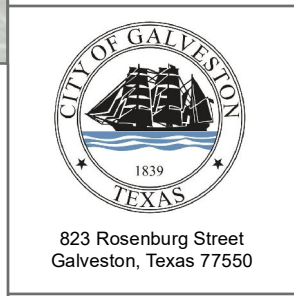

DATE: JAN 2024
 SCALE: AS NOTED

EXHIBIT 468



Legend

Project Area of Influence

Structure Flood Depth (> 0.5')

- Existing
- Removed

Flooded Parcel Area (> 50%)

- Existing
- Removed

CITY OF GALVESTON
STORMWATER MASTER PLAN (SWMP)

KARANKAWA BEACH & GULF PALMS
 PROPOSED DRAINAGE IMPROVEMENT PROJECT
 10-YEAR STRUCTURE & PARCEL BENEFIT METRICS

PREPARED: JKB
CHECKED: AEP
APPROVED: MJM

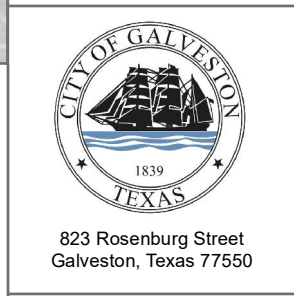

DATE: JAN 2024
SCALE: AS NOTED

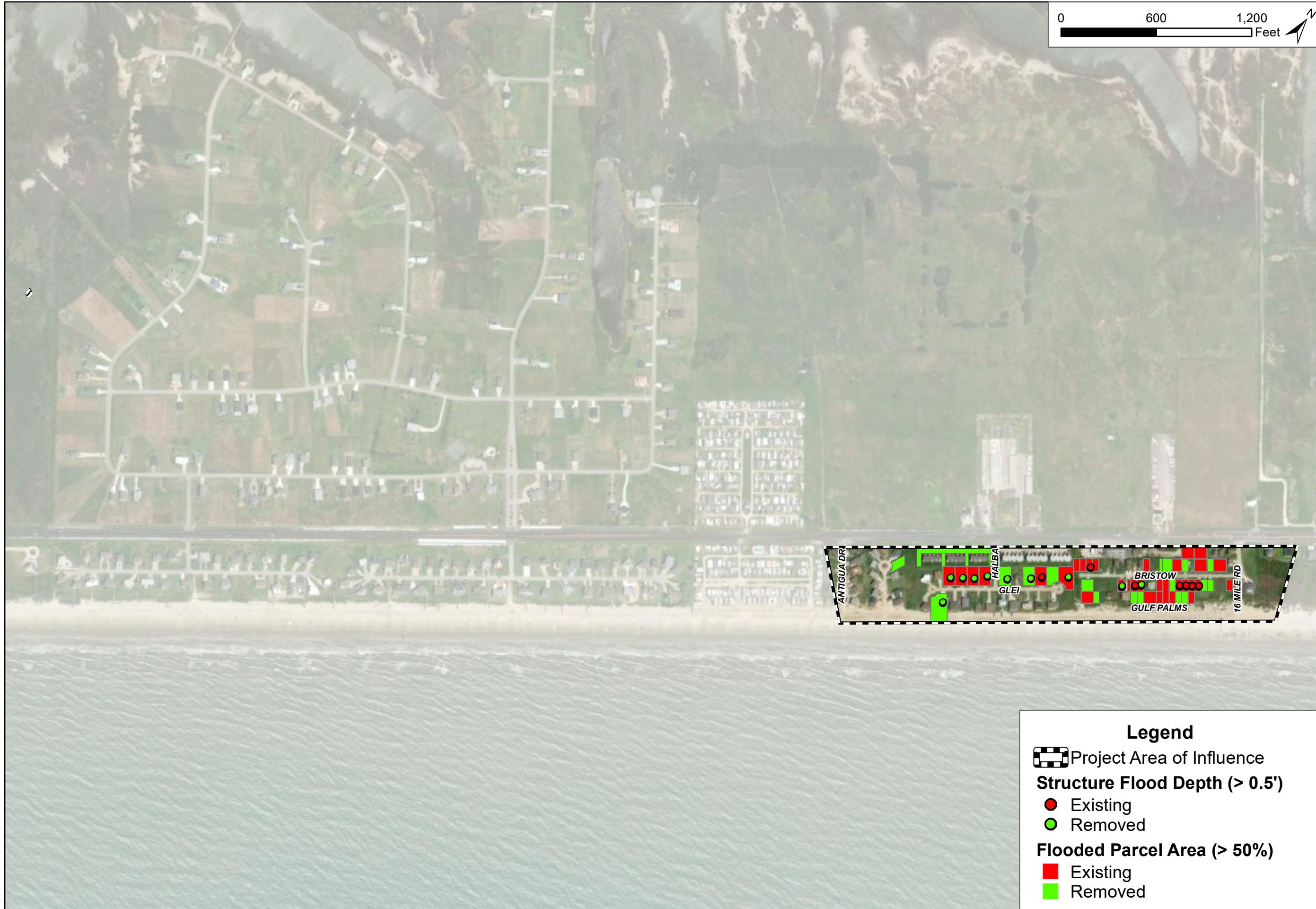

EXHIBIT 469





Legend

 Project Area of Influence

Structure Flood Depth (> 0.5')

-  Existing
-  Removed

Flooded Parcel Area (> 50%)

-  Existing
-  Removed

CITY OF GALVESTON
STORMWATER MASTER PLAN (SWMP)

KARANKAWA BEACH & GULF PALMS
 PROPOSED DRAINAGE IMPROVEMENT PROJECT
 25-YEAR STRUCTURE & PARCEL BENEFIT METRICS

PREPARED: JKB
 CHECKED: AEP
 APPROVED: MJM

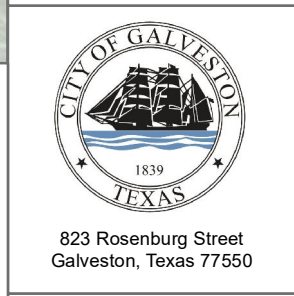

DATE: JAN 2024
 SCALE: AS NOTED

EXHIBIT 470

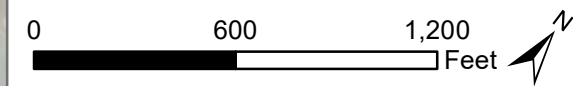
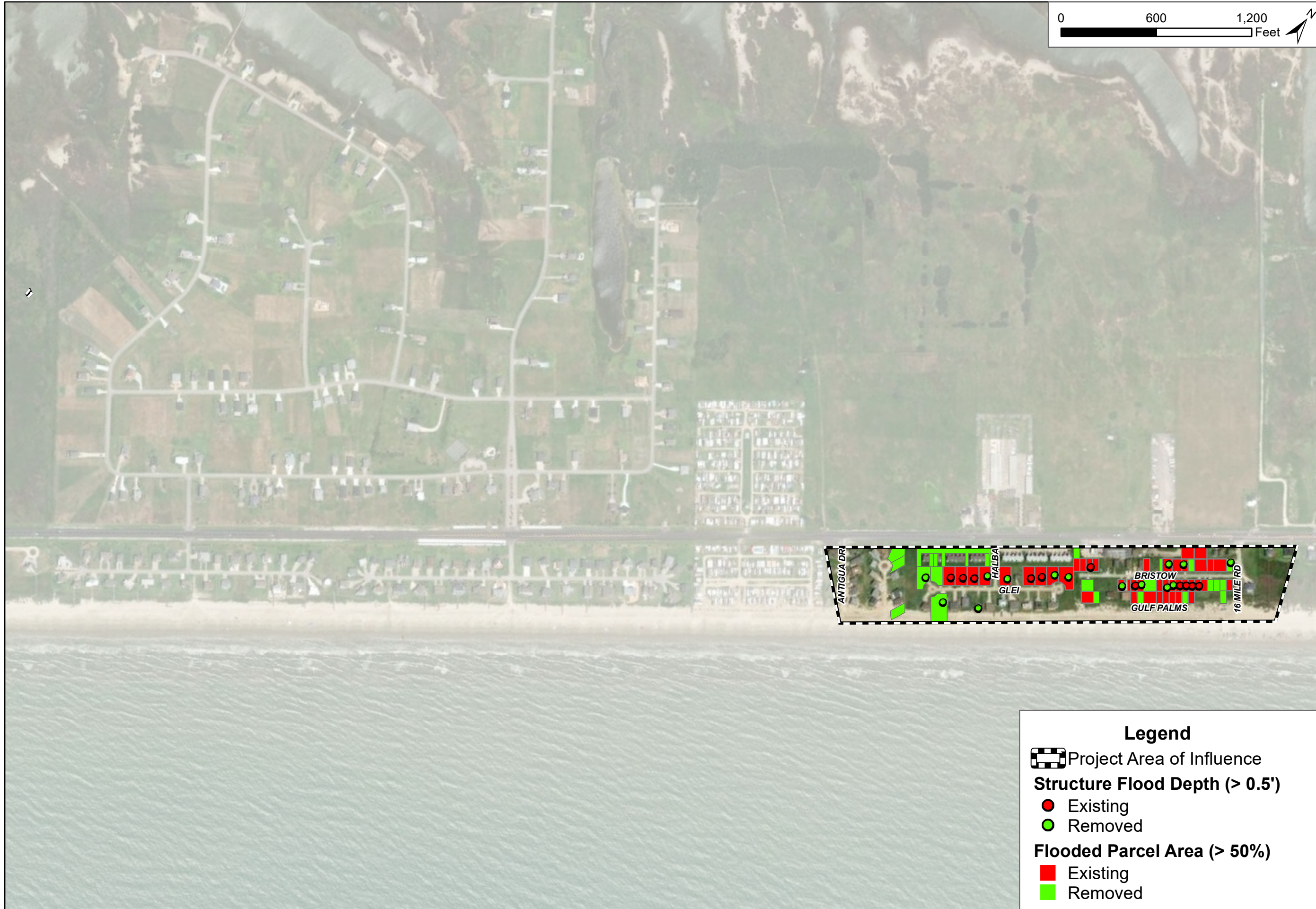

CITY OF GALVESTON
STORMWATER MASTER PLAN (SWMP)

KARANKAWA BEACH & GULF PALMS
PROPOSED DRAINAGE IMPROVEMENT PROJECT
100-YEAR STRUCTURE & PARCEL BENEFIT METRICS

PREPARED: JKB
CHECKED: AEP
APPROVED: MJM



823 Rosenberg Street
Galveston, Texas 77550

DATE: JAN 2024
SCALE: AS NOTED

EXHIBIT 471

Legend

Project Area of Influence

Structure Flood Depth (> 0.5')

- Existing
- Removed

Flooded Parcel Area (> 50%)

- Existing
- Removed



City of Galveston

DEPARTMENT OF ENGINEERING

Robert L. Winiecke, P.E., CFM, Director of Infrastructure & Engineering
rwiniecke@galvestontx.gov | Office Number: (409) 797-3664 | www.galvestontx.gov

PRE-QUALIFIED ENGINEERING FIRMS*

NO. ¹	FIRM NAME	STREET ¹ / TRAFFIC ²	DRAINAGE	WATER - DISTRIBUTION	WATER - PLANT, STORAGE, PUMPING	SEWER - COLLECTIONS	WASTEWATER - TREATMENT	GEOTECH ¹ / STRUCTURAL ² / FACILITY ³ / ELECTRICAL ⁴	CONST. ENGINEERING MGMT
1	Alliance Geotechnical Group, Inc.							X	
2	Ally General Services, LLC	X ¹²	X						X
3	Alpha Testing, LLC							X	
4	Arceneaux Wilson & Cole, LLC	X ¹²	X	X	X	X	X		X
5	Ardurra Group	X ¹²	X	X	X	X	X	X ²³	X
6	Arredondo, Zepeda & Brunz, LLC	X ¹²	X	X	X	X	X		X
7	Binkley & Barfield, Inc.	X ¹	X	X		X	X		X
8	Blackline Engineering, LLC	X ¹	X	X		X			X
9	CivilTech Engineering, Inc.,	X ¹²	X	X		X		X ²	X
10	CSRS, LLC	X ¹²	X						X
11	Dally + Associates							X ²³	X
12	DE Corp	X ¹	X	X	X	X	X		X
13	Earth Engineering, Inc.							X ¹	
14	EHRA Engineering	X ¹²		X	X	X	X	X ²	X
15	EJES, Inc.	X ¹²	X	X		X		X ¹	X
16	Eustis Engineering, LLC							X ¹	
17	Freese and Nichols, Inc.	X ¹²	X	X	X	X	X	X ³	X
18	GC Engineering, Inc.	X ¹²	X	X		X		X ²	X
19	Halff Associates, Inc.	X ¹²	X	X	X	X	X	X ²³⁴	X
20	HDR Engineering, Inc.	X ¹²	X	X	X	X	X	X ¹²³⁴	X
21	HR Green	X ¹²	X	X	X	X	X		X
22	HT&J, LLC		X						
23	Huitt-Zollars, Inc.	X ¹	X	X		X		X ³	X
24	HVJ Associates, Inc.	X ¹		X	X	X	X	X ¹	X
25	IDS Engineering Group	X ¹	X	X	X	X			
26	Infrastructure Associates, Inc.		X				X		
27	Intercoastal Consultants, LLC		X						
28	Kimley-Horn & Associates, Inc.	X ¹²	X	X	X	X	X		
29	Lockwood, Andrews and Newman	X ¹²	X	X	X	X	X	X ²³⁴	
30	McDonough Engineering Corporation	X ¹	X	X	X	X			X
31	Millennium Engineers Group, inc.							X ¹	
32	Pape-Dawson Engineering, Inc.	X ¹	X			X	X		
33	Professional Service Industries, Inc.							X ¹	
34	Raba Kistner, Inc.							X ¹	
35	Riner Engineering, Inc.							X ¹	
36	RJN Group, Inc.	X ¹		X	X	X			X
37	Stantec Consulting Services, Inc.	X ¹²	X	X	X	X	X	X ¹²³⁴	X
38	T. Baker Smith, LLC	X ¹	X	X	X	X	X	X ²	X
39	Terracon Consultants, LLC							X ¹	
40	Tetra Tech, Inc.			X	X	X	X		
41	The Goodman Corporation	X ¹²							
42	Walter P Moore	X ¹²	X	X	X	X		X ²³	
43	WGI, Inc.	X ¹²	X	X		X		X ¹²⁴	X
44	Zarinkelk Engineering Services, Inc.	X ¹²	X	X		X	X	X ²³	
45	Zero/Six Consulting, LLC							X ³	





City of Galveston

DEPARTMENT OF ENGINEERING

Robert L. Winiecke, P.E., CFM, Director of Infrastructure & Engineering
rwiniecke@galvestontx.gov | Office Number: (409) 797 - 3664 | www.galvestontx.gov

Date: February 27, 2025

To: Brian Maxwell, City Manager
Honorable Mayor and City Council Members

From: Robert L. Winiecke, P.E., CFM, Director of Infrastructure & Engineering

Project Location: Seawolf Park

Project: Seawolf Park WWTP (CIP #S2402)

Request: Consider for approval a professional services contract with Arceneaux Wilson & Cole, LLC. (AWC) to conduct the engineering design of the Seawolf Park Wastewater Treatment Plant (WWTP) project for the City of Galveston in the amount of \$199,615.00; Authorizing the City Manager to execute all necessary documents upon final approval by the City Attorney.

Prior Council Action:

A. There has been no prior City Council action taken on this item.

Current Situation:

- A. The city has had plans to replace the existing Wastewater Treatment Plant (WWTP) located at Seawolf Park for many years.
- B. In 2018, a design was prepared to build a new fixed placement WWTP at this site.
- C. The project was released for proposals in 2015 and came in over budget.
- D. The design package for this project was revised in 2018 and released for proposals a second time and came in over budget again.
- E. The Utilities Director desires to go in a new direction than previously planned, in which the city would procure a portable package plant system that can be removed from the site in the wake of a pending natural disaster.
- F. Utilizing a portable package plant will allow for a more cost-effective installation.
- G. The new WWTP will be sized for a flow of 15,000 GPD which is sufficient to handle the flows generated by the equivalent of one hundred (100) single-family residences.

Fiscal Impact Report:

This project is identified in the FY2025-FY2029 Capital Improvement Plan (CIP) as Project No. S2402, and the following table shows the funding allocation for this project:

Funding Source	Amount
2022 Wastewater CO's	\$199,615.00
Total:	\$199,615.00



Alternatives:

1. Approve this request and authorize Staff to begin the engineering design phase of the Seawolf Park WWTP project for the city.
2. Instruct Staff to seek out another firm to prepare the engineering design for the city and delay this project.

Staff Recommendation:

Staff recommends approving the professional services contract with AWC to prepare the engineering design for the Seawolf Park WWTP for the City of Galveston.

Respectfully Submitted,



Robert Winiecke, P.E., CFM
Director of Infrastructure and Engineering

Attachments:

Contract # COG-CON-25-319
Pre-Qualified Engineer's List



City of Galveston

Purchasing Division

purchasing@galvestontx.gov | 409.797.3579 | www.galvestontx.gov

1/29/2025

Arceneaux Wilson & Cole LLC
3120 Central Mall Drive
Port Arthur, Texas, 77642
keith.zotzky@awceng.com

RE: IDIQ

Dear Sir/Madam:

The City of Galveston is pleased to inform you that your company has been selected to receive a contract for the above item. No contract is awarded until such time as approved by the City Council of the City of Galveston. Staff anticipates the City of Galveston Council to approve the award on 2/20/2025. This is a multi vendor award contract and payment will be made by a purchase order issued by the City of Galveston. The City appreciates the time and effort given to your solicitation.

The State of Texas adopted a required form through House Bill 1295. It is called the Disclosure of Interested Parties – Form 1295. It is required for all of our vendors with contracts of at least \$1,000,000.00 or that have gone before and been approved by Galveston's City Council. Please visit https://www.ethics.state.tx.us/whatsnew/elf_info_form1295.htm to fill out the required document. You will need to print, sign, as an unsworn declaration, before filing with the City.

Your contract number from the City of Galveston is COG-CON-25-319; you will need this number when filling out the form online. Please include the following documents with your signed and notarized contract: completed Form 1295, and Certificate of Insurance, naming the City of Galveston as the additional insured. Return all originals to the address above, or you may scan a color copy of the documents listed above to purchasing@galvestontx.gov, no later than 5 business days. Please contact us if you have any questions.

Sincerely,

Michael Caruso – CTCD
Purchasing Manager
Finance Department - Purchasing



AGREEMENT FOR PROFESSIONAL SERVICES

This Agreement (the "Agreement") is made and entered into this 20th day of February 2025, by and between:

The Owner: **City of Galveston ("CITY" or "Owner")**
823 Rosenberg Street
Galveston, Texas 77550

and

The Service Provider: **Arceneaux Wilson & Cole LLC ("Service Provider")**
3120 Central Mall Drive
Port Arthur, TX 77642

for

The Project: RFQ 22-03 IDIQ
Engineering Services for Seawolf Park Wastewater Treatment Plant

The Owner and the Service Provider agree as follows:

1. SERVICE PROVIDER SERVICES

The Service Provider agrees to perform the services specifically described in Exhibit 1 (and any applicable exhibits attached herein), and all other professional services reasonably inferable from Exhibit 1 (and any applicable exhibits attached herein), and necessary for complete performance of the Service Provider's obligations under this Agreement. To the extent of any conflict between the terms in Exhibit 1 (and any applicable exhibits attached herein), and this Agreement, the terms of this Agreement shall prevail.

2. TERM:

Agreement shall be effective upon execution by the Owner for three (3) years, unless sooner terminated under the terms set forth herein.

3. COMPENSATION

The Service Provider compensation for professional services shall be as described in Exhibit 1.

The City shall not be responsible for payment to the Service Provider for any additional services or expenses, except upon an agreement for additional services.

Prior to commencing any additional service, the Service Provider shall prepare an additional proposal detailing the scope of the additional services and the proposed fee for those services. The Service Provider shall proceed to perform additional services only after written acceptance of the additional service and fee by Owner.

Each additional service accepted by Owner and performed by the Service Provider shall become part of this agreement and shall be subject to all the terms and conditions of this agreement.

4. SERVICE PROVIDER RESPONSIBILITIES

The Service Provider agrees and acknowledges that Owner is entering into this Agreement in reliance on the Service Provider's represented professional abilities with respect to performing professional services, duties, and obligations under this Agreement.

The Service Provider shall perform its Services:

- (1) Standard of Care - with the professional skill and care ordinarily provided by competent engineers practicing in the same or similar locality and under the same or similar circumstances and professional license; and
- (2) Expeditiously in accordance with the usual and customary professional standards of care, skill and diligence consistent with good engineering practices for firms in Texas that provide professional design services for projects that are similar in size, and scope, to the Project, and
- (3) in compliance with all applicable federal, municipal, and State of Texas laws, regulations, codes, ordinances, orders and with those of any other body having jurisdiction.

The Service Provider agrees and acknowledges that there are no obligations, commitments, or impediments of any kind known to the Service Provider that will limit or prevent performance by the Service provider of its services. Also, the Service Provider shall not engage in any activity that would reasonably appear to compromise the Service Provider's professional standard of care.

The Service Provider hereby agrees to correct, at its own cost, any of its services, and the services of its consultants, that do not meet the standard of care.

The Service Provider shall at all times provide sufficient personnel to accomplish all services in a timely manner. The Service Provider shall manage its services, administer the Project and coordinate other professional services as necessary for the complete performance of the Service Provider's obligations under this Agreement.

The Service Provider shall designate a representative primarily responsible for Services under this Agreement. The designated representative shall act on behalf of the Service Provider with respect to all phases of the Service Provider's Services and shall be available as required for the benefit of the Project and Owner. The designated representative shall not be changed without prior approval of the Owner, which approval shall not be unreasonably withheld.

Services shall be accurate and free from material errors or omissions. The Service Provider shall promptly correct any known or discovered error, omission, or other defect in the plans, drawings, specifications, or other services provided by the Service Provider without any additional cost or expense to Owner.

The Service Provider shall furnish all the respective executed Appendices as required in Exhibit 3.

5. THE OWNER'S RESPONSIBILITIES

The Owner shall provide the Service Provider with a full description of the requirements of the Project.

The Owner shall furnish surveys, geotechnical reports or other special investigations of the Project site as requested by the Service Provider and as reasonably necessary for the completion of services. The Owner shall furnish structural, mechanical, chemical and other laboratory tests as reasonably required. The Service Provider shall provide prompt written notice to the Owner if the Service Provider becomes aware of any error, omission or inconsistency in the information provided.

Access to Information - It is agreed that all information, data, reports and records and maps as are existing, available and necessary for the carrying out of the work outlined above shall be furnished to the Service Provider by the Owner and its agencies. The Owner and its agencies will cooperate with the Service Provider in every way possible to facilitate the performance of the work described in the Agreement.

The Owner will review the Service Provider's drawings, specifications and other documents of service produced by the Service Provider (collectively the "Design Documents") in the performance of its obligations under this agreement as required. Owner will notify the Service Provider of any design fault or defect in services or Design Documents of which Owner becomes aware.

The Owner designates Robert Winiecke P.E. as its representative authorized to act in the Owner's behalf with respect to the Project. The Service Provider designates Keith Zotzky P.E., as it representative authorized to act in the Service Provider's behalf with respect to the Project. Any change or addition of representative of either party shall be provided to the other in writing.

6. INDEPENDENT CONTRACTOR

The parties are independent contractors as to each other. Nothing in this Agreement shall be construed as creating any agency or employment relationship. Neither party shall make any representations tending to create an apparent or implied agency or employment relationship. Neither party has the authority to act for the other or to create obligations or debts binding on the other. Neither party shall be responsible for any obligations or expenses incurred by the other.

7. PAYMENTS TO SERVICE PROVIDER

The Service Provider shall present monthly Applications for Payment to the Owner detailing the Services and approved Additional Services performed and the approved Reimbursable Expenses incurred for the Project in the previous month. With each application for payment, the Service Provider shall submit payroll information, receipts, invoices and any other evidence of payment which Owner or its designated representatives shall deem necessary to support the amount requested.

Owner shall promptly review the Application for Payment and notify the Service Provider whether the Application is approved or disapproved, in whole or in part. Owner shall promptly pay the Service Provider for all approved services and expenses. For purposes of Texas Government Code § 2251.021(a)(2), the date performance of services is completed is the date when the Owner's representative approves the Application for Payment.

Owner shall have the right to withhold from payments due to the Service Provider such sums as are necessary to protect Owner against any loss or damage which may result from negligence by the Service Provider or failure of the Service Provider to perform its obligations under this Agreement.

8. DIRECT SALARY EXPENSE

Direct Salary Expense ("DSE") is defined as the actual salaries of the Service Provider's personnel directly engaged on the Project, expressed on an hourly wage basis prior to deductions for employment taxes and employee-paid benefits. DSE shall not include the costs of mandatory and customary employer provided contributions and employee benefits, overhead expenses or profit relating to the Project. Any multiplier applied to the DSE shall be for the purpose of covering all employer provided contributions and employee benefits, overhead expenses, and profits.

Prior to commencing Services, Service Provider shall identify all personnel who will be assigned to the Project along with their titles and DSE hourly wage. Refer to Exhibit 2.

9. ACCOUNTING RECORDS

Records of the Service Provider's costs, reimbursable expenses pertaining to the Project, and payments shall be available to Owner or its authorized representative during business hours and shall be retained for three years after final Payment or abandonment of the Project, unless Owner otherwise instructs the Service Provider in writing. The Service Provider's records shall be kept in generally accepted accounting principles.

10. OWNERSHIP AND USE OF DOCUMENTS

The Design Documents prepared by the Service Provider as instruments of service are and shall remain the property of the Owner whether the Project for which they are created is executed or not. The Service Provider shall be permitted to retain copies, including reproducible copies, of the Design Documents for information and reference in connection with the Project.

The Owner shall have an irrevocable, perpetual license and right, which shall survive the termination of this Agreement, to use the Design Documents and the ideas and designs contained in them for any purpose, with or without participation of the Service Provider.

Except for such license(s) granted herein, no other license or right shall be deemed granted or implied under this agreement.

In the event the Owner uses the instruments of service without the participation of the Service Provider, the Owner releases the Service Provider from all claims and causes of action arising from such uses. Any unauthorized use of the instruments of service shall be at the Owner's sole risk.

11. COPYRIGHT

No report, maps, or other documents produced in whole or in part under this Agreement shall be the subject of an application for copyright by or on behalf of the Service Provider.

12. DISPUTE RESOLUTION

Parties shall attempt to resolve any payment disputes within sixty (60) days or the matter may be submitted to mediation.

Nothing herein shall hinder, prevent, or be construed as a waiver of Owner's right to seek redress on any disputed matter in a court of competent jurisdiction.

Nothing herein shall waive or be construed as a waiver of the Owner's sovereign immunity.

Neither the occurrence of an event giving rise to a breach of contract claim nor the pendency of a claim constitute grounds for the suspension of performance by the Service Provider, in whole or in part. Owner and Service Provider agree that any periods set forth in this Agreement for notice and cure of defaults are not waived, delayed, or suspended.

Except in the case of a breach of contract or termination for cause, in the event there is a dispute concerning this Agreement, each party shall be responsible for its own costs and expenses including attorneys' fees and court costs incurred in the course of any dispute, mediation, or legal proceeding.

13. TERMINATION FOR CAUSE

If, through any cause, the Service Provider shall fail to fulfill in a timely and proper manner their obligations under this Agreement, or if the Service Provider shall violate any of the covenants, agreements, or stipulations of this Agreement, the Owner shall thereupon have the right to terminate this Agreement by giving written notice to the Service Provider of such termination and specifying the effective date thereof, at least five (5) days before the effective date of such termination. In such event, all finished or unfinished documents, data, studies, surveys, drawings, maps, models, photographs and reports prepared by the Service Provider under this Agreement shall, at the option of the Owner, become property of the Owner and the Service Provider shall be entitled to receive just and equitable compensation for any work satisfactorily completed hereunder. Notwithstanding the above, the Service Provider shall not be relieved of liability to the Owner for damages sustained by the Owner by virtue of any breach of the Contract by the Service Provider, and the Owner may withhold any payments to the Service Provider for the purpose of set-off until such time as the exact amount of damages due the Owner from the Service Provider is determined.

14. TERMINATION FOR CONVENIENCE

The Owner may terminate this Agreement at any time by giving at least ten (10) days' notice in writing to the Service Provider. In the event of termination not the fault of the Service Provider, the Service Provider shall be entitled to compensation for all services satisfactorily performed to the termination date provided the Service Provider delivers to Owner statements, accounts, reports and other materials as required for payment along with all reports, documents and other materials prepared by Service Provider prior to termination. If this Agreement is terminated due to the fault of the Service Provider, paragraphs relative thereto shall apply.

15. INSURANCE

15.01 Insurance Coverage. The Service Provider, consistent with its status as an independent contractor, will carry and will cause its consultants to also carry, at least the following insurance, with companies authorized to do insurance business in the State of Texas or eligible surplus lines insurers operating in accordance with the *Texas Insurance Code*, having an A.M. Best Rating of B+ or better, and in amounts not less than the minimum limits of coverage described below. The costs of such insurance will be at the expense of the Service Provider.

- a) Professional Liability Insurance (errors and omissions), acceptable to and approved by the Owner, with a limit of no less than:

\$1,000,000 each claim/\$2,000,000 aggregate for projects with total project cost less than \$50,000,000;

\$2,000,000 each claim/\$2,000,000 aggregate for projects with total project costs between \$50,000,000 and \$100,000,000;

\$5,000,000 each claim/\$5,000,000 aggregate for projects with total project cost greater than \$100,000,000.

For consultants, Professional Liability Insurance (errors and omissions) limits shall be not less than \$1,000,000 each claim/\$2,000,000 aggregate.

Such insurance shall provide coverage for claims arising out of an error, omission or negligent act in the performance of professional services by or on behalf of the Service Provider. Coverage shall not be limited to bodily injury and property damage, but shall also include economic loss. Policy shall not include pollution, mold or asbestos exclusions. Claims-made coverage is acceptable, as long as the retroactive date on the policy predates the date that professional services are first performed under this Agreement. The policy must provide for the reporting of circumstances that may give rise to a claim. The policy must be continuously renewed for at least five (5) years following project completion. If coverage is allowed to lapse or the retroactive date on the policy is advanced, then Service Provider or consultant shall purchase an extended reporting period of five (5) years, or the longest extended reporting period commercially available and any physical property damage, including the loss of use thereof, bodily injury or death resulting there from.

- b) Commercial General Liability \$1,000,000 each occurrence
\$2,000,000 aggregate

The required Commercial General Liability policy will be issued on a form that insures liability for bodily injury (including death), property damage, and personal and advertising injury assumed under the terms of this Agreement.

- c) On Site Insurance: If any services are performed on Owner's premises, the Service Provider will carry and will cause its consultants also to carry the following additional insurance. The Service Provider shall furnish to Owner Certificates of Insurance as set forth below prior to the performance of any work hereunder and shall maintain such coverage during the full term of the Agreement.

Worker's Compensation	Statutory Limits
Employer's Liability	
Bodily Injury by Accident	\$100,000 each accident
Bodily Injury by Disease	\$100,000 each employee
Bodily Injury by Disease	\$100,000 policy limit
Business Auto Liability	
Single Limit	\$1,000,000 each occurrence

*** If a separate Business Auto Liability policy is not available, coverage for hired and non-owned auto liability may be endorsed on the Commercial Liability Policy.

15.01.01 Evidence of all required insurance shall be provided on a Texas Department of Insurance approved certificate form (Acord Form is a Texas Department of Insurance pre-approved form) verifying the existence of all insurance after the execution and delivery of this Agreement and prior to the performance of any services by the Service Provider under this Agreement. Additional evidence of insurance will be provided on a Texas Department of Insurance approved certificate verifying the continued existence of all required insurance no later than 30 days after each annual insurance policy renewal. All insurance policies, with the exception of worker's compensation, employer's liability and professional liability will be endorsed and name The City of Galveston, as Additional Insured for activities arising out of this Agreement on an ISO (CG 20 10 0704) or equivalent form. Workers compensation insurance policies will be endorsed to provide a waiver of subrogation in favor of The City of Galveston. Commercial General Liability and Business Auto Liability insurance policies will be endorsed to provide primary and non-contributory coverage.

15.01.02 Notice of Cancellation: Required insurance shall not be cancelable without thirty (30) days' prior written notice to Owner.

15.01.03 Service Provider is responsible for any self-insured retentions, or deductibles that apply to any policy limit required herein.

15.01.04 Certificates of Insurance. Approved Texas Department of Insurance certificates will be mailed, faxed, or emailed to the following Owner contact.

City of Galveston
ATTN: Purchasing Contract Administrator
823 Rosenberg Street
Galveston, Texas 77550
Email: Purchasing@Galvestontx.gov

Service Provider is responsible for obtaining and maintaining evidence of all required insurance from consultants and will provide copies to Owner upon request.

15.01.05 The insurance policies required in this Agreement will be kept in force for the periods specified below:

Required coverages will be kept in force until receipt of Final Payment to the Service Provider by Owner;

Workers' Compensation Insurance and Employer's Liability insurance will be kept in force until the Work has been fully performed and accepted by Owner in writing.

Professional Liability insurance (errors and omissions) shall be maintained in accordance with Section 13.01 a).

15.01.06 If Owner is damaged by failure of Service Provider (or consultant) to maintain insurance as required herein, then Service Provider shall bear all reasonable costs properly attributable to that failure.

16. INDEMNITY

FOR CONSIDERATION RECEIVED, The Service Provider shall, to the extent allowable, indemnify, save and hold OWNER of Galveston harmless, including OWNER's officers, agents, employees and servants, from any claims, actions, lawsuits, proceedings, damages, loss, judgments, liabilities or expense on account of damage to property and injuries, including death, to the extent caused by any negligent act, intentional tort, intellectual property infringement, or failure to pay a subcontractor or supplier of the Service Provider or those acting under The Service Provider's supervision or control. The Service Provider shall not be responsible, however, for any loss, damage, liability or expense on account of damage to property and injuries, including death, by which may arise from the negligence of OWNER. Service Provider shall comply with the requirements of all current applicable laws, rules and regulations and shall indemnify and hold harmless OWNER and its agency members from and against the failure to comply with those laws, and shall assume full responsibility for payments of Federal, State and local taxes on contributions imposed or required under the Social Security, worker's compensation and income tax laws.

17. ASSIGNABILITY

Service Provider shall not assign any interest in this Agreement, and shall not transfer any interest in the same (whether by assignment or novation), without the prior written consent of the Owner. Unless specifically stated to the contrary in any written consent to assignment, no assignment will release or discharge the assignor from any duty or responsibility under this Agreement.

18. VENUE, GOVERNING LAW

This Agreement shall be construed under and in accord with the laws of the State of Texas, and all obligations of the parties created hereunder are performable in Galveston County, Texas.

19. WAIVER

A delay or omission by either party in exercising any right or power under the Agreement shall not be construed as a waiver of that right or power. A waiver by either party of any term or condition of the Agreement shall not be construed as a waiver of any subsequent breach of that term or condition or of any other term or condition of the Agreement.

20. SEVERABILITY

If any provision of this Agreement is determined to be invalid or unenforceable in any respect, that determination shall not affect any other provision of this Agreement which shall be interpreted as if the invalid or unenforceable provision had not been included.

21. PROPRIETARY INTERESTS

All information owned, possessed or used by Owner which is communicated to, learned, developed or otherwise acquired by the Service Provider in the performance of services for Owner, which is not generally known to the public, shall be confidential and Service Provider shall not disclose any such confidential information, unless required by law. The Service Provider shall

not announce or advertise its engagement by Owner in connection with the Project or publicly release any information regarding the Project without the prior written approval of Owner.

22. MODIFICATION

No change in the terms of this Agreement shall be binding unless it is in writing and signed by an authorized representative of both parties.

23. FORCE MAJEURE

No party to this agreement shall be deemed in violation if it is prevented from timely performing any of its obligations by reason of labor disputes, acts of God, Pandemic, acts of the public enemy, acts of superior governmental authority, or other circumstances for which the party is not responsible or which is not in its control.

24. REPORTS AND INFORMATION

The Service Provider, at such times and in such forms as the Owner may require, shall furnish the Owner such periodic reports as it may request pertaining to the work or services undertaken pursuant to this Agreement, the costs and obligations incurred or to be incurred in connection therewith, and any other matters covered by this Agreement.

25. NOTICES

All notices permitted or required hereunder shall be in writing and shall be transmitted via certified United States mail, return receipt requested, facsimile or electronic delivery, or by private delivery service and shall be addressed as follows or to such different addresses as the Parties may from time to time designate by giving written notice to the other party of such change:

If to the City:
City of Galveston
Attn: City Manager and City Attorney
823 Rosenberg,
Galveston, TX 77550
Telephone 409-797-3520
Email: Citymanager@galvestontx.gov

If to Service Provider:
Arceneaux Wilson & Cole LLC
Attn: Keith Zotzky
3120 Central Mall Drive
Telephone: 409-724-7888
Email: keith.zotzky@awceng.com

Notices shall be deemed effective upon receipt.

26. CYBERSECURITY PLAN

The Vendor shall establish, implement, and maintain a Cybersecurity Plan. This plan shall describe the processes and procedures that will be followed to ensure the appropriate security of IT resources that are developed, processed, or used under this contract. The Vendor Cybersecurity Plan shall comply with applicable laws.

27. EXHIBITS

All Exhibits attached hereto are incorporated herein by reference for all purposes as part of this Agreement. To the extent of any conflict, this Agreement will control.

- Exhibit 1 – Scope of Services and Compensation
- Exhibit 2 – Direct Salary Expense (DSE) Rates
- Exhibit 3 – Appendix A – Proposal Document
 - Appendix B – Conflict of Interest Form Executed
 - Appendix C – House Bill 13, 19, 89 Verification Form Executed
 - Appendix D – Property Tax Statement Executed
 - Appendix E – Nepotism Statement Executed
 - Appendix F – Non-Collusion Statement Executed
 - Appendix G – Document 00435 Debarment, Suspension Ineligibility & Voluntary Exclusion (49 CFR PART 29) Executed
 - Appendix I – Federal Clauses Executed

28. ENTIRE AGREEMENT

This Agreement supersedes all prior agreements, written or oral, between the Service Provider and Owner and constitutes the entire and integrated Agreement and understanding between the parties with respect to the subject matter of the Agreement. This Agreement may only be amended by a written instrument signed by both parties.

29. APPROPRIATIONS

The obligations of the City to make payment under this Contract are expressly subject to appropriations by the City of funds that are lawfully available to be applied to such purpose.

IN WITNESS WHEREOF, the parties have executed this Agreement in duplicate on the day and year first above written.

CITY OF GALVESTON, TEXAS

ARCENEUX WILSON & COLE LLC

By: _____

City Manager

By:  _____
DocuSigned by:
E8807529F67B422...

Company Representative

ATTEST:



City Secretary

APPROVED AS TO FORM

City Attorney

EXHIBIT 1
SCOPE OF SERVICES AND COMPENSATION

Engineering Design Phase:

- Review COG provided topographical survey data for site of proposed wastewater treatment plant.
- Perform supplemental topographical survey of critical locations for the proposed influent and effluent piping and proposed discharge point.
- Conduct a geotechnical investigation and provide a written report with building and subsurface tank foundation recommendations.
- Provide biological design calculations for the wastewater treatment plant.
- Provide windstorm certification for WWTP enclosure.
- Provide detailed signed & sealed plan sheets for the design of the new wastewater treatment plant. Engineering design plan sheets will include:
 - General construction notes.
 - Site improvements plan inclusive of necessary grading and drainage.
 - At-grade and subsurface foundation designs and details.
 - Subsurface reinforced concrete tank design and details.
 - Yard piping design including piping for connection of basins to WWTP mechanical equipment, intermediate piping for WWTP basins, and details for tie in to existing COG sanitary sewer system influent and effluent discharge infrastructure.
 - Innovatreat wastewater treatment plant equipment drawings including prescreening baffles, coarse bubble mixing system, fine bubble aeration, submersible transfer pump, portable foam core FRP structure, mini-membrane batch reactor treatment skid, and mini-SCADA.
 - Process flow diagram and P&ID.
 - Electrical service connection including standby generator and automatic transfer switch.
 - Provide horizontal and vertical control for construction.
- Prepare project specific technical specifications as necessary.
- Assist COG in preparing the Project Manual to include table of contents, bid form, technical specifications, and other necessary project appendices.
- Conduct bi-weekly project coordination meetings (anticipated 4-month design timeline).

Construction Engineering Phase:

- Attend the COG's Pre-Bid meeting.
- Answer any questions during bidding and prepare addenda, if necessary.

- Assist COG in tabulating the bids.
- Assist COG with evaluation of the received proposal packages.
- Prepare a Letter of Recommendation COG for award of the construction contract.
- Assist COG in conducting a pre-construction conference.
- Conduct site inspections as necessary during construction.
- Conduct bi-weekly construction progress meetings for the duration of the project (anticipated 270 calendar days) alternating between both in-person and virtual attendance.
- Review and approve monthly pay requests submitted by the contractor.
- Review and approve construction submittals.
- Review and respond to RFI's during the construction phase.
- Prepare change orders and required documentation COG's approval.
- Assist COG with substantial completion walkthrough and form subsequent punch list for contractor.
- Coordinate equipment start-up with wastewater treatment plant manufacturer and COG.
- Prepare project closeout documentation including "Record of Construction Drawings" based on mark-ups supplied by the contractor.
- Attend 1-Year Warranty Inspection walkthrough with COG and form subsequent punch list for contractor.

PROFESSIONAL FEE

Based upon our scope of work and understanding of the project, we propose to be compensated on a lump sum basis a fee of \$243,625.00 for the complete scope of services as described above.

The breakdown of our fees is as follows:

1. Engineering Design Phase - \$199,615.00
2. Construction Engineering Phase – \$44,010.00

We recommend a period of 4-months to perform the proposed engineering design scope of services as described within this proposal. Progress invoices, billed on a percentage basis in line with overall project progress, will be completed monthly.

Engineering Scope of Services Notes

Based on coordination with TCEQ, no permit amendment work to COG's current TPDES Discharge Permit is necessary for the scope of work as currently written. If the existing discharge infrastructure is deemed unusable, a permit amendment will need to be prepared for the new discharge point and infrastructure.

"Special Services" would apply to any work outside the scope described above and would be based on our attached, standard hourly rates. Prior authorization for "Special Services" will be needed in all cases unless authorization is granted to a limited budget in advance of performing any "Special Services". No extra work or charges outside of the scope outlined above would be performed without written authorization. Costs associated with reproduction services (copies, prints, specifications, exhibits, etc.) are included in our estimated cost for this project. Payment for any application fees, permits, inspection fees, etc. will be the responsibility of COG, made payable to each particular entity.

EXHIBIT 2
DIRECT SALARY EXPENSE (DSE) RATES

**HOURLY RATE SHEET
2025**

ENGINEERING SERVICES

Principal Engineer	\$ 250.00
Project Manager	\$ 235.00
Staff Engineer	\$ 220.00
Graduate Engineer, EIT	\$ 200.00
Engineering Intern	\$ 180.00
Designer	\$ 155.00
Design Technician III	\$ 105.00
Design Technician II	\$ 90.00
Design Technician I	\$ 75.00

CONSTRUCTION SERVICES

Resident Field Rep	\$ 115.00
---------------------------	------------------

GIS / DATABASE SERVICES

GIS Project Consulting	\$ 150.00
GIS Database Design	\$ 125.00

GIS Database Technician \$ 100.00

SURVEYING SERVICES

RPLS \$ 160.00

Survey Coordinator \$ 120.00

2-Man Crew \$ 140.00

3-Man Crew \$ 190.00

LiDAR Services Project Specific Quote

ADMINISTRATIVE

IT Support \$ 150.00

Project Support \$ 75.00

REIMBURSABLE EXPENSES

Subcontracted Services Cost + 10%

Materials & Direct Costs Cost + 10%

Reproductions & Plotting At Cost

Mileage IRS Standard Mileage Rate

EXHIBIT 3
APPENDICES

Appendix A – Proposal Document

Submittal Checklist: (To determine validity of Proposal)

- Appendix A must be included in the submittal.
- Appendix B – G all forms must be complete and included in the submittal.

By checking the below box(es), you are acknowledging the contents of the document(s) relating to the listed appendices, and agreeing to their terms:

- | | |
|---|--|
| <input checked="" type="checkbox"/> Appendix B – Conflict of Interest | <input checked="" type="checkbox"/> Appendix E – Nepotism Statement |
| <input checked="" type="checkbox"/> Appendix C – House Bill 13, 19, 89 Verification | <input checked="" type="checkbox"/> Appendix F – Non-Collusion Statement |
| <input checked="" type="checkbox"/> Appendix D – Property Tax Statement | <input checked="" type="checkbox"/> Appendix G – Certification Regarding Debarment |

All Proposals delivered to the City of Galveston shall include this page with the submittal.	
RFQ Number:	22-03
Project Title:	IDIQ Engineering Services
Submittal Deadline:	11:00 A.M ; June 22, 2022
<u>Proposer Information:</u>	
Proposer's Legal Name:	Arceneaux Wilson & Cole LLC
Address:	3120 Central Mall Drive
City, State & Zip	Port Arthur, Texas 77642
Federal Employers Identification Number #	47-1128982
Phone Number:	409 724-7888
Fax Number:	
E-Mail Address:	Joe.Wilson@awceng.com
<u>Proposer Authorization</u>	
<p>I, the undersigned, have the authority to execute this Proposal in its entirety as submitted and enter into an agreement on behalf of the Proposer.</p>	
Printed Name and Position of Authorized Representative: <u>Joe M Wilson, Jr, PE</u>	
Signature of Authorized Representative: 	
Signed this <u>22</u> (day) of <u>June</u> (month), <u>2022</u> (year)	

Appendix B – Form CIQ

INFORMATION REGARDING VENDOR CONFLICT OF INTEREST QUESTIONNAIRE

WHO: The following persons must file a Conflict of Interest Questionnaire with the City if the person has an employment or business relationship with an officer of the City that results in taxable income exceeding \$2,500 during the preceding twelve – month period, or an officer or a member of the officer’s family has accepted gifts with an aggregate value of more than \$250 during the previous twelve – month period and the person engages

in any of the following actions:

1. contracts or seeks to contract for the sale or purchase of property, goods or services with the City, including any of the following:
 - a. written and implied contracts, utility purchases, purchase orders, credit card purchases and any purchase of goods and services by the City;
 - b. contracts for the purchase or sale of real property, personal property including an auction of property;
 - c. tax abatement and economic development agreements;
2. submits a Proposal to sell goods or services, or responds to a request for proposal for services;
3. enters into negotiations with the City for a contract; or
4. applies for a tax abatement and/or economic development incentive that will result in a contract with the City

THE FOLLOWING ARE CONSIDERED OFFICERS OF THE CITY:

1. Mayor and City Council Members;
2. City Manager;
3. Board and Commission members and appointed members by the Mayor and City Council;
4. Directors of 4A and 4B development corporations;
5. The executive directors or managers of 4A and 4B development corporations; and
6. Directors of the City of Galveston who have authority to sign contracts on behalf of the City.

EXCLUSIONS: A questionnaire statement need not be filed if the money paid to a local government official was a political contribution, a gift to a member of the officer’s family from a family member; a contract or purchase of less than \$2,500 or a transaction at a price and subject to terms available to the public; a payment for food, lodging, transportation or entertainment; or a transaction subject to rate or fee regulation by a governmental entity or agency.

WHAT: A person or business that contracts with the City or who seeks to contract with the City must file a "Conflict of Interest Questionnaire" (FORM CIQ) which is available online at www.ethics.state.tx.us and a copy of which is attached to this guideline. The form contains mandatory disclosures regarding "employment or business relationships" with a municipal officer. Officials may be asked to clarify or interpret various portions of the questionnaire.

WHEN: The person or business must file:

1. the questionnaire – no later than seven days after the date the person or business begins contract discussions or negotiations with the municipality, or submits an application, responds to a request for proposals or Proposals, correspondence, or other writing related to a potential contract or agreement with the City; and
2. an updated questionnaire – within seven days after the date of an event that would make a filed questionnaire incomplete or inaccurate.

It does not matter if the submittal of a Proposal or proposal results in a contract. The statute requires a vendor to file a FORM CIQ at the time a proposal is submitted or negotiations commence.

WHERE: The vendor or potential vendor must mail or deliver a completed questionnaire to the Finance Department. ***The Finance Department is required by law to post the statements on the City’s website.***

ENFORCEMENT: Failure to file a questionnaire is a Class C misdemeanor punishable by a fine not to exceed \$500. It is an exception to prosecution that the person files a FORM CIQ not later than seven business days after the person received notice of a violation.

NOTE: The City does not have a duty to ensure that a person files a Conflict of Interest Questionnaire.

CONFLICT OF INTEREST QUESTIONNAIRE
For vendor or other person doing business with local governmental entity

FORM CIQ

This questionnaire reflects changes made to the law by H.B. 1491, 80th Leg., Regular Session.

**OFFICE
USE
ONLY**

This questionnaire is being filed in accordance with Chapter 176, Local Government Code by a person who has a business relationship as defined by Section 176.001(1-a) with a local governmental entity and the person meets requirements under Section 176.006(a).

Date
Received

By law this questionnaire must be filed with the records administrator of the local governmental entity not later than the 7th business day after the date the person becomes aware of facts that require the statement to be filed. See Section 176.006, Local Government Code.

A person commits an offense if the person knowingly violates Section 176.006, Local Government Code. An offense under this section is a Class C misdemeanor.

1. Name of person who has a business relationship with local governmental entity.

Not Applicable

2. Check this box if you are filing an update to a previously filed questionnaire.

(The law requires that you file an updated completed questionnaire with the appropriate filing authority not later than the 7th business day after the date the originally filed questionnaire becomes incomplete or inaccurate.)

3. Name of local government officer with whom filer has employment or business relationship.

 Name of Officer

This section (item 3 including subparts A, B, C & D) must be completed for each officer with whom the filer has an employment or other business relationship as defined by Section 176.001(1-a), Local Government Code. Attach additional pages to this Form CIQ as necessary.

- A. Is the local government officer named in this section receiving or likely to receive taxable income, other than investment income, from the filer of the questionnaire?
 Yes No
- B. Is the filer of the questionnaire receiving or likely to receive taxable income, other than investment income, from or at the direction of the local government officer named in this section AND the taxable income is not received from the local governmental entity?
 Yes No
- C. Is the filer of this questionnaire employed by a corporation or other business entity with respect to which the local government officer serves as an officer or director, or holds an ownership of 10 percent or more?
 Yes No
- D. Describe each employment or business relationship with the local government officer named in this section.

4. 

 Signature of person doing business with the governmental entity

6/22/22

 Date

Adopted 06-29-2007

**THIS DOCUMENT MUST BE COMPLETED AND SUBMITTED AS IT IS A PART OF
 THE SOLICITATION PACKAGE AS MENTIONED IN SECTION 7 OF THE
 PROPOSAL.**

Appendix C - House Bills 13, 19 & 89 Verification

Pursuant to Senate Bill 13 of the 87th regular Texas Legislature session:

Verification Regarding Boycotting Energy Companies – Pursuant to Chapter 2274, Texas Government Code, Contractor verifies (1) it does not boycott energy companies, and (2) it will not boycott energy companies during the term of this Agreement. Contractor acknowledges this Agreement may be terminated and payment withheld if this verification is inaccurate. (Note: This provision only applies in a contract that (1) has a value of \$100,000 or more that is to be paid wholly or partly from public funds and (2) is with a for-profit entity, not including a sole proprietorship, that has ten (10) or more full-time employees.)

Pursuant to Senate Bill 19 of the 87th regular Texas Legislature session:

Discrimination Against Firearm Entities – In accordance with Texas Government Code Chapter 2274, Contractor verifies that it does not have a practice, policy, guidance or directive that discriminates against a firearm entity or firearm trade association; and will not discriminate during the term of the contract against a firearm entity or firearm trade association. This section only applies if: (i) Contractor has ten (10) or more full-time employees and (ii) this Agreement has a value of \$100,000 or more to be paid under the terms of this Agreement; and does not apply: (i) if Contractor is a sole proprietor, a non-profit entity, or a governmental entity; (ii) to a contract with a sole-source provider; or (iii) to a contract for which none of the bids from a company were able to provide the required certification.

Pursuant to Sections 2270.001, 2270.002, 808.001, Texas Government Code:

1. *“Boycott Israel” means refusing to deal with, terminating business activities with, or otherwise taking any action that is intended to penalize, inflict economic harm on, or limit commercial relations specifically with Israel, or with a person or entity doing business in Israel or in an Israeli-controlled territory, but does not include an action made for ordinary business purposes; and*
2. *“Company” has the meaning assigned by Section 808.001, except that the term does not include a sole proprietorship.*
3. *Section only applies to a contract that is between a governmental entity and a company with 10 or more full-time employees; and has a value of \$100,000 or more that is to be paid wholly or partly from public funds of the governmental entity.*

I, Joe M Wilson, Jr, PE (Person name), the undersigned representative of (Company or

Business Name) Arceneaux Wilson & Cole LLC (hereinafter referred to as Company)

being an adult over the age of eighteen (18) years of age, do hereby depose and verify under oath that the company named-above, under the provisions of Subtitle F, Title 10, Government Code Chapter 2270; depose and verify under oath that the Company, under the provisions of Subtitle A, Title 8, Government Code, is amended by adding Chapter 809; do hereby depose and verify under oath that the Company, under the provisions of Subtitle F, Title 10, Government Code, is amended by adding Chapter 2274 will not discriminate and/or boycott any of these provisions outlined and defined in House Bills 13, 19 and 89.

6/22/22

DATE

SIGNATURE OF COMPANY REPRESENTATIVE

THIS DOCUMENT MUST BE COMPLETED AND SUBMITTED AS IT IS A PART OF THE SOLICITATION PACKAGE AS MENTIONED IN SECTION 7 OF THE PROPOSAL.

Appendix D – Property Tax Statement

FAILURE TO COMPLETE THIS ATTACHMENT SHALL RESULT IN THE PURCHASING SUPERVISOR DEEMING YOUR BID OR PROPOSAL “NON-RESPONSIVE.”

The City of Galveston, Texas has adopted the following policy:

The City of Galveston will not do business with any person or business that owes delinquent property taxes to the City.

Please indicate whether you or your company, owe delinquent property taxes to the City whether an assumed name, partnership, corporation, or any other legal form.

I do not owe the City property taxes that are delinquent.

I owe City property taxes that are delinquent on property located at

Joe M Wilson, Jr, PE

Proposer's Printed or Typed Name

Proposer's Signature

June 22, 2022

Date

THIS DOCUMENT MUST BE COMPLETED, SIGNED, AND SUBMITTED AS IT IS A PART OF THE SOLICITATION PACKAGE AS MENTIONED IN SECTION 7 OF THE PROPOSAL.

Appendix E – Nepotism Statement

FAILURE TO COMPLETE THIS ATTACHMENT SHALL RESULT IN THE PURCHASING SUPERVISOR DEEMING YOUR BID OR PROPOSAL "NON-RESPONSIVE."

The Bidder or Proposer or any officer, if the Bidder or Proposer is other than an individual, shall state whether Bidder or Proposer has a relationship, either by blood or marriage, with any official or employee of the City of Galveston by completing the following:

If the Proposer or Bidder is an individual:

_____ I am not related by blood or marriage to any official or employee of the City of Galveston

_____ I am related by blood or marriage to the following official(s) or employee(s) of the City of Galveston

Name and title of City Official

Or employee: _____

Relationship: _____

If the Bidder or Proposer is **NOT** an individual:

The officers of the company submitting this bid or proposal are not related by blood or marriage to any official or employee of the City of Galveston.

_____ The officers of the company submitting this Proposal are related by blood or marriage to the following official(s) or employee(s) of the City of Galveston.

Name and title of officer: _____

Employee and title of City Official or Employee: _____

Relationship: _____

THIS DOCUMENT MUST BE COMPLETED AND SUBMITTED AS IT IS A PART OF THE SOLICITATION PACKAGE AS MENTIONED IN SECTION 7 OF THE PROPOSAL.

Appendix F – Non-Collusion Statement

THE UNDERSIGNED AFFIRM THAT THEY ARE DULY AUTHORIZED TO EXECUTE THIS CONTRACT, THAT THIS COMPANY, FIRM, PARTNERSHIP OR INDIVIDUAL HAS NOT PREPARED THIS PROPOSAL IN COLLUSION WITH ANY OTHER PROPOSER, AND THAT THE CONTENTS OF THIS PROPOSAL AS TO PRICES, TERMS OR CONDITIONS OF SAID PROPOSAL HAVE NOT BEEN COMMUNICATED BY THE UNDERSIGNED NOR BY ANY EMPLOYEE OR AGENT TO ANY OTHER PERSON ENGAGED IN THIS TYPE OF BUSINESS PRIOR TO THE OFFICIAL OPENING OF THIS PROPOSAL.

PROPOSER Arceneaux Wilson & Cole LLC

ADDRESS 3120 Central Mall Drive, Port Arthur, TX 77642

PHONE 409 724-7888

FAX _____

PROPOSER (SIGNATURE) _____

PROPOSER (PRINTED NAME) _____

Joe M Wilson, Jr, PE

POSITION WITH COMPANY President

SIGNATURE OF COMPANY OFFICIAL
AUTHORIZING THIS PROPOSAL

COMPANY OFFICIAL
(PRINTED NAME) Joe M Wilson, Jr, PE

OFFICIAL POSITION President

THIS DOCUMENT MUST BE COMPLETED, SIGNED, AND SUBMITTED AS IT IS A PART OF THE SOLICITATION PACKAGE AS MENTIONED IN SECTION 7 OF THE PROPOSAL.

Appendix G – Document 00435 The City of Galveston, Texas

PROPOSER'S CERTIFICATION REGARDING DEBARMENT, SUSPENSION, INELIGIBILITY AND VOLUNTARY EXCLUSION (49 CFR PART 29)

The undersigned certifies, by submission of this proposal or acceptance of this contract, that neither Contractor nor its principals is presently debarred, suspended, proposed for debarment, declared ineligible, or voluntarily excluded from participation in this transaction by any Federal department or agency. Proposer agrees that by submitting this proposal that Proposer will include this clause without modification in all lower tier transactions, solicitations, proposals, contracts, and subcontracts. Where the Proposer or any lower tier participant is unable to certify to this statement, that participant shall attach an explanation to this document.

Certification-the above information is true and complete to the best of my knowledge and belief.

Joe M Wilson, Jr, PE

(Printed or typed Name of Signatory)

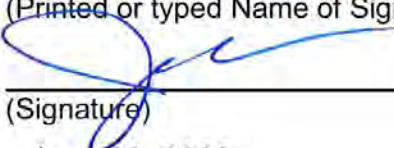

(Signature)

June 22, 2022

(Date)

NOTE: The penalty for making false statements in offers is prescribed in **18 U.S.C. 1001**

END OF DOCUMENT 00435-FAA

**THIS DOCUMENT MUST BE COMPLETED, SIGNED, AND SUBMITTED AS IT IS A
PART OF THE SOLICITATION PACKAGE AS MENTIONED IN SECTION 7 OF THE
PROPOSAL.**

Appendix H – ACH Form



The City of Galveston would like to thank you for the services you and your company have provided for us in the past, present, and in the future. For those services provided you have more than likely received payments via a paper check in the mail. As we all know, that process is slow, inefficient, and costly for us and for you as the recipient.

Mail can be delayed, lost, or even stolen causing payments to be late and we may then face penalties and late fees. The City of Galveston would like to streamline our payment process with electronic payments. These payments will be transferred electronically from our financial institute to your financial institute. The process will get your payments to you in a quicker, more reliable, and more efficient manner.

If you would like to sign up to start receiving all of your payments via ACH / Wire Transfers, please fill out the authorization forms and return to the City of Galveston Finance Department.

Please email to:

accountspayable@galvestontx.gov

Or mail to:

City of Galveston
Finance Department
P.O. Box 779
Galveston, TX 77553

If you have any questions or concerns, please do not hesitate to call Accounts Payable at 409.797.3569. Please put the Purchase Order Number on your invoices to ensure prompt payment. Again, we appreciate you and the services your business provide for the City of Galveston.

Sincerely,

A handwritten signature in black ink that reads "Michael W. Loftin". The signature is written in a cursive style.

Michael W. Loftin
Assistant City Manager – Finance



City of Galveston

ACH Payment Agreement Form

Authorization Agreement

I hereby authorize the City of Galveston to initiate ACH deposits to my account at the financial institution named below.

Further, I agree not to hold the City of Galveston responsible for any delay or loss of funds due to incorrect or incomplete information supplied by me or by my financial institution, or due to an error on the part of my financial institution in depositing funds to my account.

This agreement will remain in effect until the City of Galveston receives a written notice of cancellation from me or my financial institution, or until I submit a new ACH Payment Agreement Form to the City of Galveston Finance Department.

Account Information

Name of Financial Institution: _____

Financial Institute Address: _____

Routing Number: _____

Account Number: _____

SWIFT Code: (if applicable) _____

Executed agreement must include a confirmation of the banking information from an Authorized Bank Official on bank letterhead with the Authorized Bank Official's business card.

Signature

Company Name: _____

Authorized Signature: _____

Printed Name: _____ Title: _____

Contact Phone Number: _____ Date: _____

FOR CITY USE ONLY:

Verified by: _____	Date Verified: _____
--------------------	----------------------

RETURN THIS FORM ONLY UPON AWARD.

APPENDIX I – FEDERAL CLAUSES

The following, federally mandated, clauses require acknowledgement of the offeror and are considered part of the contract between the City of Galveston and the awarded vendor. Any offeror that does not acknowledge the clauses below shall be considered non-responsive and will not be considered for award.

1. **NO GOVERNMENTAL OBLIGATION TO THIRD PARTIES:** The Owner and Contractor acknowledge and agree that, notwithstanding any concurrence by the Federal Government in or approval of the solicitation or award of the underlying contract, absent the express written consent by the Federal Government, the Federal Government is not a party to this contract and shall not be subject to any obligations or liabilities to the Owner, Contractor, or any other party (whether or not a party to that contract) pertaining to any matter resulting from the underlying contract.
2. **PROGRAM FRAUD AND FALSE OR FRAUDULENT STATEMENTS AND RELATED ACTS:** Contractor acknowledges that the provisions of the Program Fraud Civil Remedies Act of 1986, as amended, 31 U.S.C. § 3801 *et seq.*, "Administrative Remedies for False Claims and Statements," apply to its actions pertaining to this Project. Upon execution of the underlying contract, the Contractor certifies or affirms the truthfulness and accuracy of any statement it has made, it makes, it may make, or causes to be made, pertaining to the underlying contract for which this contract work is being performed. In addition to other penalties that may be applicable, the Contractor further acknowledges that if it makes, or causes to be made, a false, fictitious, or fraudulent claim, statement, submission, or certification, the Federal Government reserves the right to impose the penalties of the Program Fraud Civil Remedies Act of 1986 on the Contractor to the extent the Federal Government deems appropriate.
3. **ACCESS TO RECORDS AND REPORTS:** The contractor agrees to provide (insert name of state agency or local or Indian tribal government), (insert name of recipient), the FEMA Administrator, the Comptroller General of the United States, or any of their authorized representatives access to any books, documents, papers, and records of the Contractor which are directly pertinent to this contract for the purposes of making audits, examinations, excerpts, and transcriptions. The Contractor agrees to permit any of the foregoing parties to reproduce by any means whatsoever or to copy excerpts and transcriptions as reasonably needed. The contractor agrees to provide the FEMA Administrator or his authorized representatives access to construction or other work sites pertaining to the work being completed under the contract."
4. **FEDERAL CHANGES:** Contractor shall at all times comply with all applicable FTA regulations, policies, procedures and directives, including without limitation those listed directly or by reference in the Master Agreement between Owner and FTA, as they may be amended or promulgated from time to time during the term of this contract. Contractor's failure to so comply shall constitute a material breach of this contract.
5. **EQUAL EMPLOYMENT OPPORTUNITY:** The contractor will not discriminate against any employee or applicant for employment because of race, color, religion, sex, or national origin. The contractor will take affirmative action to ensure that applicants are

employed, and that employees are treated during employment without regard to their race, color, religion, sex, or national origin. Such action shall include, but not be limited to the following: Employment, upgrading, demotion, or transfer; recruitment or recruitment advertising; layoff or termination; rates of pay or other forms of compensation; and selection for training, including apprenticeship. The contractor agrees to post in conspicuous places, available to employees and applicants for employment, notices to be provided setting forth the provisions of this nondiscrimination clause. The contractor will, in all solicitations or advertisements for employees placed by or on behalf of the contractor, state that all qualified applicants will receive considerations for employment without regard to race, color, religion, sex, or national origin. The contractor will send to each labor union or representative of workers with which he has a collective bargaining agreement or other contract or understanding, a notice to be provided advising the said labor union or workers' representatives of the contractor's commitments under this section, and shall post copies of the notice in conspicuous places available to employees and applicants for employment. The contractor will comply with all provisions of Executive Order 11246 of September 24, 1965, and of the rules, regulations, and relevant orders of the Secretary of Labor. The contractor will furnish all information and reports required by Executive Order 11246 of September 24, 1965, and by rules, regulations, and orders of the Secretary of Labor, or pursuant thereto, and will permit access to his books, records, and accounts by the administering agency and the Secretary of Labor for purposes of investigation to ascertain compliance with such rules, regulations, and orders. In the event of the contractor's noncompliance with the nondiscrimination clauses of this contract or with any of the said rules, regulations, or orders, this contract may be canceled, terminated, or suspended in whole or in part and the contractor may be declared ineligible for further Government contracts or federally assisted construction contracts in accordance with procedures authorized in Executive Order 11246 of September 24, 1965, and such other sanctions as may be imposed and remedies invoked as provided in Executive Order 11246 of September 24, 1965, or by rule, regulation, or order of the Secretary of Labor, or as otherwise provided by law. The vendor will include the portion of the sentence immediately preceding paragraph (1) and the provisions of paragraphs (1) through (7) in every subcontract or purchase order unless exempted by rules, regulations, or orders of the Secretary of Labor issued pursuant to section 204 of Executive Order 11246 of September 24, 1965, so that such provisions will be binding upon each subcontractor or vendor. The contractor will take such action with respect to any subcontract or purchase order as the administering agency may direct as a means of enforcing such provisions, including sanctions for noncompliance: Provided, however, That in the event a contractor becomes involved in, or is threatened with, litigation with a subcontractor or vendor as a result of such direction by the administering agency the contractor may request the United States to enter into such litigation to protect the interests of the United States."

6. **DISADVANTAGED BUSINESS ENTERPRISE (DBE):** This contract is subject to the requirements of Title 49, Code of Federal Regulations, Part 26, *Participation by Disadvantaged Business Enterprises in Department of Transportation Financial Assistance Programs*. **The City's overall goal through 2022 is .7% of all**

procurements. The City's DBE Policy is located on the City's Website here:
<https://www.galvestontx.gov/228/Disadvantaged-Business-Enterprise-Progra>

Contractor shall not discriminate on the basis of race, color, national origin, or sex in the performance of this contract. Contractor shall carry out applicable requirements of 49 CFR Part 26 in the award and administration of this DOT-assisted contract. Failure by Contractor to carry out these requirements is a material breach of this contract, which may result in the termination of this contract or such other remedy as the Owner deems appropriate. Each subcontract Contractor signs with a subcontractor must include the assurance in this paragraph (see 49 CFR 26.13(b)).

Bidders are required to document sufficient DBE participation to meet these goals or, alternatively, document adequate good faith efforts to do so, as provided for in 49 CFR 26.53. Award of this contract is conditioned on submission of the following with the sealed bid:

- **Names and addresses of DBE firms that will participate in this contract;**
- **Description of the work each DBE will perform;**
- **Dollar amount of the participation of each DBE firm participating;**
- **Written documentation of the bidder/offeror's commitment to use a DBE subcontractor whose participation it submits to meet the contract goal;**
- **Written confirmation from the DBE that it is participating in the contract as provided in the prime contractor's commitment; and**
- **If the contract goal is not met, evidence of good faith efforts to do so.**

The contractor is required to pay its subcontractors performing work related to this contract for satisfactory performance of that work no later than 30 days after the contractor's receipt of payment for that work from the owner. In addition, Contractor is required to return any retainage payments to those subcontractors within 30 days after incremental acceptance of the subcontractor's work by the owner and Contractor's receipt of the partial retainage payment related to the subcontractor's work.

The contractor must promptly notify owner whenever a DBE subcontractor performing work related to this contract is terminated or fails to complete its work, and must make good faith efforts to engage another DBE subcontractor to perform at least the same amount of work. The contractor may not terminate any DBE subcontractor and perform that work through its own forces or those of an affiliate without prior written consent of owner.

- 7. GOVERNMENT-WIDE SUSPENSION AND DEBARMENT:** This contract is a covered transaction for purposes of 2 C.F.R. pt. 180 and 2 C.F.R. pt. 3000. As such the contractor is required to verify that none of the contractor, its principals (defined at 2 C.F.R. § 180.995), or its affiliates (defined at 2 C.F.R. § 180.905) are excluded (defined at 2 C.F.R. § 180.940) or disqualified (defined at 2 C.F.R. § 180.935). The contractor must comply with 2 C.F.R. pt. 180, subpart C and 2 C.F.R. pt. 3000, subpart C and must include a requirement to comply with these regulations in any lower tier covered transaction it enters into. This certification is a material representation of fact relied upon by (insert name of subrecipient). If it is later determined that the contractor did not comply with 2 C.F.R. pt. 180, subpart C and 2 C.F.R. pt.3000, subpart C, in addition to remedies available to (name of state agency serving as recipient and name of subrecipient), the Federal Government may pursue available remedies, including but

not limited to suspension and/or debarment. The bidder or proposer agrees to comply with the requirements of 2 C.F.R. pt. 180, subpart C and 2 C.F.R. pt. 3000, subpart C while this offer is valid and throughout the period of any contract that may arise from this offer. The bidder or proposer further agrees to include a provision requiring such compliance in its lower tier covered transactions.

- 8. BUY AMERICA REQUIREMENTS:** Contractor agrees to comply with 49 U.S.C. 5323(j) and 49 C.F.R. Part 661, which provide that Federal funds may not be obligated unless steel, iron, and manufactured products used in FTA-funded projects are produced in the United States, unless a waiver has been granted by FTA or the product is subject to a general waiver. General waivers are listed in 49 C.F.R. 661.7, and include final assembly in the United States for 15-passenger vans and 15- passenger wagons produced by Chrysler Corporation, and microcomputer equipment and software. Separate requirements for rolling stock are set out at 49 U.S.C. 5323(j)(2)(C) and 49 C.F.R. 661.11. Rolling stock must be assembled in the United States and have a 60 percent domestic content.

A proposer or offeror must submit to the Owner the appropriate Buy America certification with all bids or offers on FTA-funded contracts, except those subject to a general waiver. Bids or offers that are not accompanied by a completed Buy America certification must be rejected as nonresponsive. This requirement does not apply to lower tier subcontractors. Offeror, by signing this document, certifies that it will meet the requirements of 49 U.S.C. 5323(j)(1) and the applicable regulations in 49 C.F.R. Part 661.5. The City may require additional certification forms with an executed agreement.

- 9. INCORPORATION OF FEDERAL TRANSIT ADMINISTRATION (FTA) TERMS – FTA Circular 4220.1E:**

The preceding provisions include, in part, certain Standard Terms and Conditions required by DOT, whether or not expressly set forth in the preceding contract provisions. All contractual provisions required by DOT, as set forth in FTA Circular 4220.1E, are hereby incorporated by reference. Anything to the contrary herein notwithstanding, all FTA mandated terms shall be deemed to control in the event of a conflict with other provisions contained in this Agreement. Contractor shall not perform any act, fail to perform any act, or refuse to comply with any owner requests which would cause owner to be in violation of the FTA terms and conditions.

- 10. BREACHES AND DISPUTE RESOLUTION 49 CFR PART 18, FTA CIRCULAR 4220.1E:**

Disputes - Disputes arising in the performance of this Contract which are not resolved by agreement of the parties shall be decided in writing by the authorized representative of owner. This decision shall be final and conclusive unless within ten (10) days from the date of receipt of its copy, Contractor mails or otherwise furnishes a written appeal to the [title of employee]. In connection with any such appeal, Contractor shall be afforded an opportunity to be heard and to offer evidence in support of its position. The decision of the owner shall be binding upon Contractor and Contractor shall abide by the decision.

Performance During Dispute - Unless otherwise directed by owner, Contractor shall continue performance under this Contract while matters in dispute are being resolved.

Claims for Damages - Should either party to the Contract suffer injury or damage to person or property because of any act or omission of the party or of any of his employees, agents or others for whose acts he is legally liable, a claim for damages therefor shall be

made in writing to such other party within a reasonable time after the first observance of such injury of damage.

Remedies - Unless this contract provides otherwise, all claims, counterclaims, disputes and other matters in question between the owner and the Contractor arising out of or relating to this agreement or its breach will be decided by arbitration if the parties mutually agree, or in a court of competent jurisdiction within the State in which the owner is located.

Rights and Remedies - The duties and obligations imposed by the Contract Documents and the rights and remedies available thereunder shall be in addition to and not a limitation of any duties, obligations, rights and remedies otherwise imposed or available by law. No action or failure to act by the owner, or Contractor shall constitute a waiver of any right or duty afforded any of them under the Contract, nor shall any such action or failure to act constitute an approval of or acquiescence in any breach thereunder, except as may be specifically agreed in writing.

11. CONTRACT WORK HOURS AND SAFETY STANDARDS ACT:

1. **Overtime requirements** - No contractor or subcontractor contracting for any part of the contract work which may require or involve the employment of laborers or mechanics shall require or permit any such laborer or mechanic in any workweek in which he or she is employed on such work to work in excess of forty hours in such workweek unless such laborer or mechanic receives compensation at a rate not less than one and one-half times the basic rate of pay for all hours worked in excess of forty hours in such workweek.
2. **Violation; liability for unpaid wages; liquidated damages** - In the event of any violation of the clause set forth in paragraph (1) of this section the contractor and any subcontractor responsible therefor shall be liable for the unpaid wages. In addition, such contractor and subcontractor shall be liable to the United States for liquidated damages. Such liquidated damages shall be computed with respect to each individual laborer or mechanic, including watchmen and guards, employed in violation of the clause set forth in paragraph (1) of this section, in the sum of \$10 for each calendar day on which such individual was required or permitted to work in excess of the standard workweek of forty hours without payment of the overtime wages required by the clause set forth in paragraph (1) of this section.
3. **Withholding for unpaid wages and liquidated damages** – The Owner shall, upon its own action or upon written request of an authorized representative of the Department of Labor, withhold or cause to be withheld, from any moneys payable on account of work performed by the contractor or subcontractor under any such contract or any other Federal contract with the same prime contractor, or any other federally-assisted contract subject to the Contract Work Hours and Safety Standards Act, which is held by the same prime contractor, such sums as may be determined to be necessary to satisfy any liabilities of such contractor or subcontractor for unpaid wages and liquidated damages as provided in the clause set forth in paragraph (2) of this section.
4. **Subcontracts** - Contractor or subcontractor shall insert in any subcontracts the clauses set forth in paragraphs (1) through (4) of this section and also a clause requiring the subcontractors to include these clauses in any lower tier subcontracts. The prime contractor shall be responsible for compliance by any subcontractor or

lower tier subcontractor with the clauses set forth in paragraphs (1) through (4) of this section.

12. LOBBYING:

Byrd Anti-Lobbying Amendment, 31 U.S.C. § 1352 (as amended)

Contractors who apply or bid for an award of \$100,000 or more shall file the required certification. Each tier certifies to the tier above that it will not and has not used Federal appropriated funds to pay any person or organization for influencing or attempting to influence an officer or employee of any agency, a member of Congress, officer or employee of Congress, or an employee of a member of Congress in connection with obtaining any Federal contract, grant, or any other award covered by 31 U.S.C. § 1352. Each tier shall also disclose any lobbying with non-Federal funds that takes place in connection with obtaining any Federal award. Such disclosures are forwarded from tier to tier up to the recipient.

APPENDIX A, 44 C.F.R. PART 18 – CERTIFICATION REGARDING LOBBYING

Certification for Contracts, Grants, Loans, and Cooperative Agreements

(To be submitted with each bid or offer exceeding \$100,000)

The undersigned [Contractor] certifies, to the best of his or her knowledge, that:

1. No Federal appropriated funds have been paid or will be paid, by or on behalf of the undersigned, to any person for influencing or attempting to influence an officer or employee of an agency, a Member of Congress, an officer or employee of Congress, or an employee of a Member of Congress in connection with the awarding of any Federal contract, the making of any Federal grant, the making of any Federal loan, the entering into of any cooperative agreement, and the extension, continuation, renewal, amendment, or modification of any Federal contract, grant, loan, or cooperative agreement.
2. If any funds other than Federal appropriated funds have been paid or will be paid to any person for influencing or attempting to influence an officer or employee of any agency, a Member of Congress, an officer or employee of Congress, or an employee of a Member of Congress in connection with this Federal contract, grant, loan, or cooperative agreement, the undersigned shall complete and submit Standard Form - LLL, "Disclosure Form to Report Lobbying," in accordance with its instructions.
3. The undersigned shall require that the language of this certification be included in the award documents for all subawards at all tiers (including subcontracts, subgrants and contracts under grants, loans, and cooperative agreements) and that all subrecipients shall certify and disclose accordingly.

This certification is a material representation of fact upon which reliance was placed when this transaction was made or entered into. Submission of this certification is a prerequisite for making or entering into this transaction imposed by 31, U.S.C. § (as amended by the Lobbying Disclosure Act of 1995). Any person who fails to the required certification shall be subject to a civil penalty of not less than \$10,000 and not more than \$100,000 for each such failure.

The Contractor certifies or affirms by signing this contract the truthfulness and accuracy of each statement of its certification and disclosure, if any. In addition, Contractor understands and agrees that the provisions of 31 U.S.C. § 3801 *et seq* apply to this certification and disclosure, if any.

- 13. CLEAN AIR 42 U.S.C. § 7401 et seq.:** Contractor agrees to comply with all applicable standards, orders or regulations issued pursuant to the Clean Air Act, as amended, 42 U.S.C. §§ 7401 *et seq*. The Contractor agrees to report each violation to the Owner and understands and agrees that the Owner will, in turn, report each violation as required to assure notification to the State of Texas, Federal Emergency Management Agency, and the appropriate Environmental Protection Agency Regional Office.

Contractor also agrees to include these requirements in each subcontract exceeding \$150,000 financed in whole or in part with Federal assistance provided by FEMA.

- 14. CLEAN WATER REQUIREMENTS 33 U.S.C. 1251 et seq.:** Contractor agrees to comply with all applicable standards, orders or regulations issued pursuant to the Federal Water Pollution Control Act, as amended, 33 U.S.C. 1251 *et seq*. Contractor agrees to report each violation to the Owner and understands and agrees that the Owner will, in turn, report each violation as required to assure notification to the State of Texas, Federal Emergency Management Agency, and the appropriate Environmental Protection Agency Regional Office. Contractor also agrees to include these requirements in each subcontract exceeding \$150,000 financed in whole or in part with Federal assistance provided by FEMA.

15. PROCUREMENT OF RECOVERED MATERIALS 42 U.S.C 6962:

(1) In the performance of this contract, the Contractor shall make maximum use of products containing recovered materials that are EPA- designated items unless the product cannot be acquired—

- (i) Competitively within a timeframe providing for compliance with the contract performance schedule;
- (ii) Meeting contract performance requirements; or
- (iii) At a reasonable price.

(2) Information about this requirement, along with the list of EPA-designate items, is available at EPA's Comprehensive Procurement Guidelines web site,

<https://www.epa.gov/smm/comprehensive-procurement-guideline-cpg-program>.

16. COMPLIANCE WITH FEDERAL LAW, REGULATIONS, AND EXECUTIVE ORDERS:

This is an acknowledgement that FEMA financial assistance will be used to fund the contract only. The contractor will comply will all applicable federal law, regulations, executive orders, FEMA policies, procedures, and directives.

17. ENERGY CONSERVATION REQUIREMENTS 42 U.S.C. 6321 et seq., 49 CFR PART

18: Contractor agrees to comply with mandatory standards and policies relating to energy efficiency which are contained in the state energy conservation plan issued in compliance with the Energy Policy and Conservation Act.

18. COMPLIANCE WITH DAVIS-BACON ACT AND COPELAND “ANTI-KICKBACK”

ACT:

Minimum wages - (i) All laborers and mechanics employed or working upon the site of the work (or under the United States Housing Act of 1937 or under the Housing Act of 1949 in the construction or development of the project), will be paid unconditionally and not less often than once a week, and without subsequent deduction or rebate on any account (except such payroll deductions as are permitted by regulations issued by the Secretary of Labor under the Copeland Act (29 CFR part 3)), the full amount of wages and bona fide fringe benefits (or cash equivalents thereof) due at time of payment computed at rates not less than those contained in the wage determination of the Secretary of Labor which is attached hereto and made a part hereof, regardless of any contractual relationship which may be alleged to exist between the contractor and such laborers and mechanics.

Contributions made or costs reasonably anticipated for bona fide fringe benefits under section 1(b)(2) of the Davis-Bacon Act on behalf of laborers or mechanics are considered wages paid to such laborers or mechanics, subject to the provisions of paragraph (1)(iv) of this section; also, regular contributions made or costs incurred for more than a weekly period (but not less often than quarterly) under plans, funds, or programs which cover the particular weekly period, are deemed to be constructively made or incurred during such weekly period. Such laborers and mechanics shall be paid the appropriate wage rate and fringe benefits on the wage determination for the classification of work actually performed, without regard to skill, except as provided in 29 CFR Part 5.5(a)(4). Laborers or mechanics performing work in more than one classification may be compensated at the rate specified for each classification for the time actually worked therein: Provided, That the employer's payroll records accurately set forth the time spent in each classification in which work is performed. The wage determination (including any additional classifications and wage rates conformed under paragraph (1)(ii) of this section) and the Davis-Bacon poster (WH-1321) shall be posted at all times by the contractor and its subcontractors at the site of the work in a prominent and accessible place where it can be easily seen by the workers.

(ii)(A) The contracting officer shall require that any class of laborers or mechanics, including helpers, which is not listed in the wage determination and which is to be employed under the contract shall be classified in conformance with the wage determination. The contracting officer shall approve an additional classification and wage rate and fringe benefits therefore only when the following criteria have been met:

(1) Except with respect to helpers as defined as 29 CFR 5.2(n)(4), the work to be performed by the classification requested is not performed by a classification in the wage determination; and

(2) The classification is utilized in the area by the construction industry; and

(3) The proposed wage rate, including any bona fide fringe benefits, bears a reasonable relationship to the wage rates contained in the wage determination; and

(4) With respect to helpers as defined in 29 CFR 5.2(n)(4), such a classification prevails in the area in which the work is performed.

(B) If the contractor and the laborers and mechanics to be employed in the classification

(if known), or their representatives, and the contracting officer agree on the classification and wage rate (including the amount designated for fringe benefits where appropriate), a report of the action taken shall be sent by the contracting officer to the Administrator of the Wage and Hour Division, Employment Standards Administration, U.S. Department of Labor, Washington, DC 20210. The Administrator, or an authorized representative, will approve, modify, or disapprove every additional classification action within 30 days of receipt and so advise the contracting officer or will notify the contracting officer within the 30-day period that additional time is necessary.

(C) In the event the contractor, the laborers or mechanics to be employed in the classification or their representatives, and the contracting officer do not agree on the proposed classification and wage rate (including the amount designated for fringe benefits, where appropriate), the contracting officer shall refer the questions, including the views of all interested parties and the recommendation of the contracting officer, to the Administrator for determination. The Administrator, or an authorized representative, will issue a determination within 30 days of receipt and so advise the contracting officer or will notify the contracting officer within the 30-day period that additional time is necessary.

(D) The wage rate (including fringe benefits where appropriate) determined pursuant to paragraphs (a)(1)(ii) (B) or (C) of this section, shall be paid to all workers performing work in the classification under this contract from the first day on which work is performed in the classification.

(iii) Whenever the minimum wage rate prescribed in the contract for a class of laborers or mechanics includes a fringe benefit which is not expressed as an hourly rate, the contractor shall either pay the benefit as stated in the wage determination or shall pay another bona fide fringe benefit or an hourly cash equivalent thereof.

(iv) If the contractor does not make payments to a trustee or other third person, the contractor may consider as part of the wages of any laborer or mechanic the amount of any costs reasonably anticipated in providing bona fide fringe benefits under a plan or program, Provided, That the Secretary of Labor has found, upon the written request of the contractor, that the applicable standards of the Davis-Bacon Act have been met. The Secretary of Labor may require the contractor to set aside in a separate account assets for the meeting of obligations under the plan or program.

(v)(A) The contracting officer shall require that any class of laborers or mechanics which is not listed in the wage determination and which is to be employed under the contract shall be classified in conformance with the wage determination. The contracting officer shall approve an additional classification and wage rate and fringe benefits therefor only when the following criteria have been met:

(1) The work to be performed by the classification requested is not performed by a classification in the wage determination; and

(2) The classification is utilized in the area by the construction industry; and

(3) The proposed wage rate, including any bona fide fringe benefits, bears a reasonable relationship to the wage rates contained in the wage determination.

(B) If the contractor and the laborers and mechanics to be employed in the classification (if known), or their representatives, and the contracting officer agree on the classification and wage rate (including the amount designated for fringe benefits where appropriate), a report of the action taken shall be sent by the contracting officer to the Administrator of the Wage and Hour Division, Employment Standards Administration, Washington, DC 20210. The Administrator, or an authorized representative, will approve, modify, or disapprove every additional classification action within 30 days of receipt and so advise

the contracting officer or will notify the contracting officer within the 30-day period that additional time is necessary.

(C) In the event the contractor, the laborers or mechanics to be employed in the classification or their representatives, and the contracting officer do not agree on the proposed classification and wage rate (including the amount designated for fringe benefits, where appropriate), the contracting officer shall refer the questions, including the views of all interested parties and the recommendation of the contracting officer, to the Administrator for determination. The Administrator, or an authorized representative, will issue a determination with 30 days of receipt and so advise the contracting officer or will notify the contracting officer within the 30-day period that additional time is necessary.

(D) The wage rate (including fringe benefits where appropriate) determined pursuant to paragraphs (a)(1)(v) (B) or (C) of this section, shall be paid to all workers performing work in the classification under this contract from the first day on which work is performed in the classification.

(2) Withholding - The [*City of Galveston*] shall upon its own action or upon written request of an authorized representative of the Department of Labor withhold or cause to be withheld from the contractor under this contract or any other Federal contract with the same prime contractor, or any other federally-assisted contract subject to Davis-Bacon prevailing wage requirements, which is held by the same prime contractor, so much of the accrued payments or advances as may be considered necessary to pay laborers and mechanics, including apprentices, trainees, and helpers, employed by the contractor or any subcontractor the full amount of wages required by the contract. In the event of failure to pay any laborer or mechanic, including any apprentice, trainee, or helper, employed or working on the site of the work (or under the United States Housing Act of 1937 or under the Housing Act of 1949 in the construction or development of the project), all or part of the wages required by the contract, the [*City of Galveston*] may, after written notice to the contractor, sponsor, applicant, or owner, take such action as may be necessary to cause the suspension of any further payment, advance, or guarantee of funds until such violations have ceased.

(3) Payrolls and basic records - (i) Payrolls and basic records relating thereto shall be maintained by the contractor during the course of the work and preserved for a period of three years thereafter for all laborers and mechanics working at the site of the work (or under the United States Housing Act of 1937, or under the Housing Act of 1949, in the construction or development of the project). Such records shall contain the name, address, and social security number of each such worker, his or her correct classification, hourly rates of wages paid (including rates of contributions or costs anticipated for bona fide fringe benefits or cash equivalents thereof of the types described in section 1(b)(2)(B) of the Davis-Bacon Act), daily and weekly number of hours worked, deductions made and actual wages paid. Whenever the Secretary of Labor has found under 29 CFR 5.5(a)(1)(iv) that the wages of any laborer or mechanic include the amount of any costs reasonably anticipated in providing benefits under a plan or program described in section 1(b)(2)(B) of the Davis-Bacon Act, the contractor shall maintain records which show that the commitment to provide such benefits is enforceable, that the plan or program is financially responsible, and that the plan or program has been communicated in writing to the laborers or mechanics affected, and records which show the costs anticipated or the actual cost incurred in providing such benefits. Contractors employing apprentices or trainees under approved programs shall maintain written evidence of the registration of apprenticeship programs and certification of trainee programs, the registration of the apprentices and trainees, and the ratios and

wage rates prescribed in the applicable programs.

(ii)(A) The contractor shall submit weekly for each week in which any contract work is performed a copy of all payrolls to the [*City of Galveston*] for transmission to the Federal Transit Administration. The payrolls submitted shall set out accurately and completely all of the information required to be maintained under section 5.5(a)(3)(i) of Regulations, 29 CFR part 5. This information may be submitted in any form desired. Optional Form WH-347 is available for this purpose and may be purchased from the Superintendent of Documents (Federal Stock Number 029-005-00014-1), U.S. Government Printing Office, Washington, DC 20402. The prime contractor is responsible for the submission of copies of payrolls by all subcontractors.

(B) Each payroll submitted shall be accompanied by a "Statement of Compliance," signed by the contractor or subcontractor or his or her agent who pays or supervises the payment of the persons employed under the contract and shall certify the following:

(1) That the payroll for the payroll period contains the information required to be maintained under section 5.5(a)(3)(i) of Regulations, 29 CFR part 5 and that such information is correct and complete;

(2) That each laborer or mechanic (including each helper, apprentice, and trainee) employed on the contract during the payroll period has been paid the full weekly wages earned, without rebate, either directly or indirectly, and that no deductions have been made either directly or indirectly from the full wages earned, other than permissible deductions as set forth in Regulations, 29 CFR part 3;

(3) That each laborer or mechanic has been paid not less than the applicable wage rates and fringe benefits or cash equivalents for the classification of work performed, as specified in the applicable wage determination incorporated into the contract.

(C) The weekly submission of a properly executed certification set forth on the reverse side of Optional Form WH-347 shall satisfy the requirement for submission of the "Statement of Compliance" required by paragraph (a)(3)(ii)(B) of this section.

(D) The falsification of any of the above certifications may subject the contractor or subcontractor to civil or criminal prosecution under section 1001 of title 18 and section 231 of title 31 of the United States Code.

(iii) The contractor or subcontractor shall make the records required under paragraph (a)(3)(i) of this section available for inspection, copying, or transcription by authorized representatives of the Federal Transit Administration or the Department of Labor, and shall permit such representatives to interview employees during working hours on the job. If the contractor or subcontractor fails to submit the required records or to make them available, the Federal agency may, after written notice to the contractor, sponsor, applicant, or owner, take such action as may be necessary to cause the suspension of any further payment, advance, or guarantee of funds. Furthermore, failure to submit the required records upon request or to make such records available may be grounds for debarment action pursuant to 29 CFR 5.12.

(4) Apprentices and trainees – (i) Apprentices – Apprentices will be permitted to work at less than the predetermined rate for the work they performed when they are employed pursuant to and individually registered in a bona fide apprenticeship program registered with the U.S. Department of Labor, Employment and Training Administration, Bureau of Apprenticeship and Training, or with a State Apprenticeship Agency recognized by the Bureau, or if a person is employed in his or her first 90 days of probationary employment as an apprentice in such an apprenticeship program, who is not individually registered in the program, but who has been certified by the Bureau of Apprenticeship and Training or a State Apprenticeship Agency (where appropriate) to be eligible for probationary

employment as an apprentice. The allowable ratio of apprentices to journeymen on the job site in any craft classification shall not be greater than the ratio permitted to the contractor as to the entire work force under the registered program. Any worker listed on a payroll at an apprentice wage rate, who is not registered or otherwise employed as stated above, shall be paid not less than the applicable wage rate on the wage determination for the classification of work actually performed. In addition, any apprentice performing work on the job site in excess of the ratio permitted under the registered program shall be paid not less than the applicable wage rate on the wage determination for the work actually performed. Where a contractor is performing construction on a project in a locality other than that in which its program is registered, the ratios and wage rates (expressed in percentages of the journeyman's hourly rate) specified in the contractor's or subcontractor's registered program shall be observed. Every apprentice must be paid at not less than the rate specified in the registered program for the apprentice's level of progress, expressed as a percentage of the journeymen hourly rate specified in the applicable wage determination. Apprentices shall be paid fringe benefits in accordance with the provisions of the apprenticeship program. If the apprenticeship program does not specify fringe benefits, apprentices must be paid the full amount of fringe benefits listed on the wage determination for the applicable classification. If the Administrator of the Wage and Hour Division of the U.S. Department of Labor determines that a different practice prevails for the applicable apprentice classification, fringes shall be paid in accordance with that determination. In the event the Bureau of Apprenticeship and Training, or a State Apprenticeship Agency recognized by the Bureau, withdraws approval of an apprenticeship program, the contractor will no longer be permitted to utilize apprentices at less than the applicable predetermined rate for the work performed until an acceptable program is approved.

(ii) Trainees – Except as provided in 29 CFR 5.16, trainees will not be permitted to work at less than the predetermined rate for the work performed unless they are employed pursuant to and individually registered in a program which has received prior approval, evidenced by formal certification by the U.S. Department of Labor, Employment and Training Administration. The ratio of trainees to journeymen on the job site shall not be greater than permitted under the plan approved by the Employment and Training Administration. Every trainee must be paid at not less than the rate specified in the approved program for the trainee's level of progress, expressed as a percentage of the journeyman hourly rate specified in the applicable wage determination. Trainees shall be paid fringe benefits in accordance with the provisions of the trainee program. If the trainee program does not mention fringe benefits, trainees shall be paid the full amount of fringe benefits listed on the wage determination unless the Administrator of the Wage and Hour Division determines that there is an apprenticeship program associated with the corresponding journeyman wage rate on the wage determination which provides for less than full fringe benefits for apprentices. Any employee listed on the payroll at a trainee rate who is not registered and participating in a training plan approved by the Employment and Training Administration shall be paid not less than the applicable wage rate on the wage determination for the classification of work actually performed. In addition, any trainee performing work on the job site in excess of the ratio permitted under the registered program shall be paid not less than the applicable wage rate on the wage determination for the work actually performed. In the event the Employment and Training Administration withdraws approval of a training program, the contractor will no longer be permitted to utilize trainees at less than the applicable predetermined rate for the work performed until an acceptable program is approved.

(iii) Equal employment opportunity – The utilization of apprentices, trainees and journeymen under this part shall be in conformity with the equal employment opportunity requirements of Executive Order 11246, as amended, and 29 CFR part 30.

(5) Compliance with Copeland Act requirements – The contractor shall comply with the requirements of 29 CFR part 3, which are incorporated by reference in this contract.

(6) Subcontracts – The contractor or subcontractor shall insert in any subcontracts the clauses contained in 29 CFR 5.5(a)(1) through (10) and such other clauses as the Federal Transit Administration may by appropriate instructions require, and also a clause requiring the subcontractors to include these clauses in any lower tier subcontracts. The prime contractor shall be responsible for the compliance by any subcontractor or lower tier subcontractor with all the contract clauses in 29 CFR 5.5.

(7) Contract termination: debarment – A breach of the contract clauses in 29 CFR 5.5 may be grounds for termination of the contract, and for debarment as a contractor and a subcontractor as provided in 29 CFR 5.12.

(8) Compliance with Davis-Bacon and Related Act requirements – All rulings and interpretations of the Davis-Bacon and Related Acts contained in 29 CFR parts 1, 3, and 5 are herein incorporated by reference in this contract.

(9) Disputes concerning labor standards – Disputes arising out of the labor standards provisions of this contract shall not be subject to the general disputes clause of this contract. Such disputes shall be resolved in accordance with the procedures of the Department of Labor set forth in 29 CFR parts 5, 6, and 7. Disputes within the meaning of this clause include disputes between the contractor (or any of its subcontractors) and the contracting agency, the U.S. Department of Labor, or the employees or their representatives.

(10) Certification of eligibility – (i) By entering into this contract, the contractor certifies that neither it (nor he or she) nor any person or firm who has an interest in the contractor's firm is a person or firm ineligible to be awarded Government contracts by virtue of section 3(a) of the Davis-Bacon Act or 29 CFR 5.12(a)(1).

(ii) No part of this contract shall be subcontracted to any person or firm ineligible for award of a Government contract by virtue of section 3(a) of the Davis-Bacon Act or 29 CFR 5.12(a)(1).

(iii) The penalty for making false statements is prescribed in the U.S. Criminal Code, 18 U.S.C. 1001.

I, Joe M Wilson, Jr, PE (printed name), the undersigned, do hereby acknowledge, and agree to comply, with the above statements for the entire length of any agreement with the City of Galveston, Texas.



Signature of Authorized Company Representative

6/22/22

Date

THIS DOCUMENT MUST BE COMPLETED AND SUBMITTED AS IT IS A PART OF THE QUALIFICATIONS PACKAGE AS MENTIONED IN SECTION 7 OF THE RFQ.

CERTIFICATE OF INTERESTED PARTIES

FORM 1295

1 of 1

Complete Nos. 1 - 4 and 6 if there are interested parties. Complete Nos. 1, 2, 3, 5, and 6 if there are no interested parties.	OFFICE USE ONLY CERTIFICATION OF FILING
1 Name of business entity filing form, and the city, state and country of the business entity's place of business. Arceneaux Wilson & Cole LLC Port Arthur, TX United States	Certificate Number: 2025-1262317
2 Name of governmental entity or state agency that is a party to the contract for which the form is being filed. City of Galveston	Date Filed: 01/29/2025
3 Provide the identification number used by the governmental entity or state agency to track or identify the contract, and provide a description of the services, goods, or other property to be provided under the contract. COG-CON-25-319 Engineering Services	

4 Name of Interested Party	City, State, Country (place of business)	Nature of interest (check applicable)	
		Controlling	Intermediary
Arceneaux, Ron	Port Arthur, TX United States	X	
Wilson, Joe	Port Arthur, TX United States	X	
Cole, Keestan	Port Arthur, TX United States	X	

5 Check only if there is NO Interested Party.

6 UNSWORN DECLARATION

My name is Joe Wilson, and my date of birth is [REDACTED]

My address is 3120 Central Mall Dr, Port Arthur, Tx, 77642, USA.
(street) (city) (state) (zip code) (country)

I declare under penalty of perjury that the foregoing is true and correct.

Executed in Jefferson County, State of Texas, on the 29 day of JAN, 2025.
(month) (year)

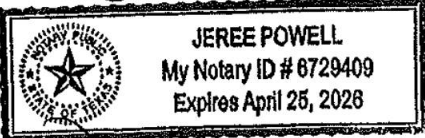

Jeree Powell

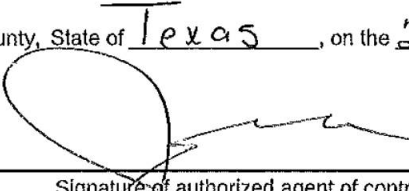

Signature of authorized agent of contracting business entity
(Declarant)



City of Galveston

DEPARTMENT OF ENGINEERING

Robert L. Winiecke, P.E., CFM, Director of Infrastructure & Engineering
rwiniecke@galvestontx.gov | Office Number: (409) 797-3664 | www.galvestontx.gov

PRE-QUALIFIED ENGINEERING FIRMS*

NO. ¹	FIRM NAME	STREET ¹ / TRAFFIC ²	DRAINAGE	WATER - DISTRIBUTION	WATER - PLANT, STORAGE, PUMPING	SEWER - COLLECTIONS	WASTEWATER - TREATMENT	GEOTECH ¹ / STRUCTURAL ² / FACILITY ³ / ELECTRICAL ⁴	CONST. ENGINEERING MGMT
1	Alliance Geotechnical Group, Inc.							X	
2	Ally General Services, LLC	X ¹²	X						X
3	Alpha Testing, LLC							X	
4	Arceneaux Wilson & Cole, LLC	X ¹²	X	X	X	X	X		X
5	Ardurra Group	X ¹²	X	X	X	X	X	X ²³	X
6	Arredondo, Zepeda & Brunz, LLC	X ¹²	X	X	X	X	X		X
7	Binkley & Barfield, Inc.	X ¹	X	X		X	X		X
8	Blackline Engineering, LLC	X ¹	X	X		X			X
9	CivilTech Engineering, Inc.,	X ¹²	X	X		X		X ²	X
10	CSRS, LLC	X ¹²	X						X
11	Dally + Associates							X ²³	X
12	DE Corp	X ¹	X	X	X	X	X		X
13	Earth Engineering, Inc.							X ¹	
14	EHRA Engineering	X ¹²		X	X	X	X	X ²	X
15	EJES, Inc.	X ¹²	X	X		X		X ¹	X
16	Eustis Engineering, LLC							X ¹	
17	Freese and Nichols, Inc.	X ¹²	X	X	X	X	X	X ³	X
18	GC Engineering, Inc.	X ¹²	X	X		X		X ²	X
19	Halff Associates, Inc.	X ¹²	X	X	X	X	X	X ²³⁴	X
20	HDR Engineering, Inc.	X ¹²	X	X	X	X	X	X ¹²³⁴	X
21	HR Green	X ¹²	X	X	X	X	X		X
22	HT&J, LLC		X						
23	Huitt-Zollars, Inc.	X ¹	X	X		X		X ³	X
24	HVJ Associates, Inc.	X ¹		X	X	X	X	X ¹	X
25	IDS Engineering Group	X ¹	X	X	X	X			
26	Infrastructure Associates, Inc.		X				X		
27	Intercoastal Consultants, LLC		X						
28	Kimley-Horn & Associates, Inc.	X ¹²	X	X	X	X	X		
29	Lockwood, Andrews and Newman	X ¹²	X	X	X	X	X	X ²³⁴	
30	McDonough Engineering Corporation	X ¹	X	X	X	X			X
31	Millennium Engineers Group, inc.							X ¹	
32	Pape-Dawson Engineering, Inc.	X ¹	X			X	X		
33	Professional Service Industries, Inc.							X ¹	
34	Raba Kistner, Inc.							X ¹	
35	Riner Engineering, Inc.							X ¹	
36	RJN Group, Inc.	X ¹		X	X	X			X
37	Stantec Consulting Services, Inc.	X ¹²	X	X	X	X	X	X ¹²³⁴	X
38	T. Baker Smith, LLC	X ¹	X	X	X	X	X	X ²	X
39	Terracon Consultants, LLC							X ¹	
40	Tetra Tech, Inc.			X	X	X	X		
41	The Goodman Corporation	X ¹²							
42	Walter P Moore	X ¹²	X	X	X	X		X ²³	
43	WGI, Inc.	X ¹²	X	X		X		X ¹²⁴	X
44	Zarinkelk Engineering Services, Inc.	X ¹²	X	X		X	X	X ²³	
45	Zero/Six Consulting, LLC							X ³	





City of Galveston

DEPARTMENT OF SANITATION

publicworks@galvestontx.gov | Office Number: (409) 797-3630 | www.galvestontx.gov

Date: February 18, 2025

To: City Manager
Mayor and City Council Members

From: Dustin Bender, Director of Solid Waste

Project location: City of Galveston Transfer Station, 5515 Harborside Drive.

Project: Repair 400amp service and Shorted Underground Feed to the processing facility.

Request: Consider for approval the repair of the existing electrical service that provides power to the Solid Waste Transfer Station processing building utilizing our current contract number, COG-CON -22-857 with Cresent Electric. This work includes bringing the existing services up to current CenterPoint and NEC standards.

Prior Council Action

None.

Background

- A. The City of Galveston owns the Solid Waste Transfer Station at 5515 Harborside Drive and contracts its operation to BFI Transfer Systems of Texas under TCEQ permit number MSW-164.
- B. The underground electrical feed for the processing building shorted out which caused damage to the electrical panel that supplies the site. A new 500 KCMIL feeder is required to restore power to Transfer building as well as a new 400amp service to comply with current electrical standards.
- C. A portable generator is currently deployed to power the tipping area of the site and.





City of Galveston

DEPARTMENT OF SANITATION

publicworks@galvestontx.gov | Office Number: (409) 797-3630 | www.galvestontx.gov

- D. Work can be performed during normal business hours and will not disrupt the Transfer Station Operation.

Fiscal Impact Report

Funding Source. Building Repairs

Budget	Funding Source	Estimated Amount
Operating Expense	Building Repairs	Total - \$30,939.33

Staff Recommendation

Approve the project quoted by Crescent Electric in the amount of \$30,939.33. Authorizing the City Manager to execute all necessary documents upon final approval by the City Attorney.



⚠ DANGER
Hazardous voltage.
Will cause death or serious injury.
• Turn power OFF before removing this ahead.
• Replace all components and shield before turning power ON.

⚠ DANGER
Hazardous voltage.
Will cause death or serious injury.
• Turn power OFF before removing this ahead.
• Replace all components and shield before turning power ON.



Bullet
CURRENT LIMITING
ECS940

Bullet
CURRENT LIMITING
ECS940

Bullet
CURRENT LIMITING
ECS940

Fuse Type "T"
1000V Max.



Quality Work by Qualified Workers

February 17, 2025

Customer: Republic Services / City of Galveston

Location: 5515 Harborside Dr, Galveston.

Project: Burnt 400amp service, Shorted Underground Feed.

Contact: Stefan Ortega / 832-628-3304

Thank you for the opportunity to quote you on the following scope of work.

Qualifications:

All work is to be performed during normal business hours.

1. Install new 400amp 3phase 480v service. The existing service is not up to current CenterPoint or NEC standards.
2. Extend service equipment rack to fit new equipment. Existing fence may need to be removed to allow NEC clearance. We will remove fence as needed; fence repairs will be done by others.
3. Demo existing UG feed feeding the adjacent building. The underground cable is shorted and compromised.
4. Install new 500 KCMIL UG feeder to adjacent building panelboard.
5. PM and visually inspect 480v panelboard, transformer and 120/240v panelboard at adjacent building. The equipment is currently not safe to energize. Minor repairs will be included in this proposal. If major repairs are needed it will be completed at an additional cost.

Labor: \$ 9,216.00

Equipment: \$ 1,400.00

Material: \$ 20,323.33

Total: \$30,939.33

This above price excludes tax and is good for 30 days unless otherwise noted.

There will be a 3% processing fee on all credit/debit card purchases.

Thank you,

Chad Theobald
(409-682-0334)



City of Galveston

Purchasing Division

purchasing@galvestontx.gov | 409.797.3579 | www.galvestontx.gov

4/6/2022

Crescent Engineering Co. Inc. dba Crescent Electric
1319 First St
La Marque, TX, 77568
crescentelectric@comcast.net

RE: Electrical Services

Dear Sir/Madam:

The City of Galveston is pleased to inform you that your company has been selected to receive a contract for the above item. No contract is awarded until such time as approved by the City Council of the City of Galveston. Staff anticipates the City of Galveston Council to approve the award on 4/28/2022. This is a multi vendor award contract and payment will be made by a purchase order issued by the City of Galveston. The City appreciates the time and effort given to your solicitation.

The State of Texas adopted a required form through House Bill 1295. It is called the Disclosure of Interested Parties – Form 1295. It is required for all of our vendors with contracts of at least \$1,000,000.00 or that have gone before and been approved by Galveston's City Council. Please visit https://www.ethics.state.tx.us/whatsnew/elf_info_form1295.htm to fill out the required document. You will need to print, sign, as an unsworn declaration, before filing with the City.

Your contract number from the City of Galveston is COG-CON-22-857; you will need this number when filling out the form online. Please include the following documents with your signed and notarized contract: completed Form 1295, and Certificate of Insurance, naming the City of Galveston as the additional insured. Return all originals to the address above, or you may scan a color copy of the documents listed above to purchasing@galvestontx.gov, no later than 5 business days. Please contact us if you have any questions.

Sincerely,

Michael Caruso – CTCD
Purchasing Manager
Finance Department - Purchasing



AGREEMENT FOR SERVICES
ELECTRICAL SERVICES

This Agreement (the "Agreement") is made and entered into this Apr 28 day of month, 2022, by and between the City of Galveston ("COG"), a Texas home-rule municipality, and **Crescent Engineering Co. Inc. dba Crescent Electric** ("Company") located at **1319 First St, La Marque, TX, 77568**. By entering into this Agreement, Company agrees that COG is entering into this agreement in its governmental capacity, and not a proprietary one.

WHEREAS, the City of Galveston desires to obtain services in connection with its "electrical services", within the City of Galveston ("COG") and **Crescent Engineering Co. Inc. dba Crescent Electric** ("Company") desires to provide such services; and

WHEREAS, this Agreement between the Parties consist of the terms and conditions set forth herein, and **Exhibit 1, Exhibit 2, and Exhibit 3**, identified as the proposal from the Company for the scope of services, and those document(s), attached and incorporated for all purposes for the following Project:

BID 22-02

NOW, THEREFORE, for and in consideration of the mutual covenants hereinafter set forth, the parties do mutually agree as follows:

1. **TERM**: Agreement shall be effective upon execution by the COG for three (3) years, unless sooner terminated under the terms set forth herein. This Agreement shall automatically renew for successive one-year periods under the existing terms and conditions, unless either party gives the other party written notice of non-renewal at least 30 days prior to such renewal date. Contract will not exceed five (5) years.

2. **SCOPE OF SERVICES**: Company will provide the services ("Work") to the COG in connection with the Project, more specifically described in **Exhibit 1** (and any applicable exhibits attached herein), attached and fully incorporated for all intents and purposes.

3. **COMPENSATION**: COG shall compensate Company for the Work at the agreed upon in **Exhibit 1**. Company will furnish an invoice to the COG detailing activities performed and reflecting actual time and expenses incurred during the preceding month. All invoices are due under Government Code Sec. 2251.021, and are payable to Company at **1319 First St, La Marque, TX, 77568**. COG shall not be responsible for any payment to Company for any additional services or expenses not specifically included in **Exhibit 1**, except upon execution of an amendment to this Agreement in writing by both parties. Parties shall attempt to resolve any payment disputes within thirty (30) days after the invoice date.

4. **SCHEDULE AND DELIVERABLES**: The COG and its agencies will cooperate with Company to facilitate the performance of the work described in the agreement. Company will perform the Work in accordance with the schedules/timetables described in detail in the attached **Exhibit 1**.

In the event that one or more of the members of the Company cannot perform because of ill health, physical disability or other reasons beyond his/her control, Company shall use its best efforts to furnish a substitute of similar stature for such member of the Company whom COG agrees to accept. COG does not have to accept any substitutes provided by the Company, but, may contract a substitute of their own.

5. **CHANGES**: The COG may request changes in the scope of the services to be performed hereunder. Such changes, including any increase or decrease in the amount of compensation to Company, which are mutually agreed upon by and between the COG and Company, shall be incorporated in written amendments to this Agreement. No changes in the terms of this Agreement shall be binding unless it is in writing and signed by an authorized representative of both parties.

6. **STANDARD OF CARE:** The standard of care for all services performed or furnished by Company under this agreement will be the care and skill ordinarily used by members of the subject profession practicing under similar circumstances at the same time and in the same locality.

7. **PERMITS:** The Company warrants and represents that it has obtained any and all permits, approvals, and licenses and necessary for electrical services. All permits associated with the project shall be the sole responsibility of Company.

8. **INDEPENDENT CONTRACTORS:** The parties are independent contractors as to each other. Nothing in this Agreement shall be construed as creating any agency or employment relationship. Neither Party shall make any representations tending to create an apparent or implied agency or employment relationship; neither party has the authority to act for the other or to create obligations or debts binding on the other; and neither party shall be responsible for any obligations or expenses incurred by the other.

It is the intent of the parties to this agreement that the Company as an independent contractor will control the manner and means of its performance(s). The COG will control the scheduling of the performance(s). The exclusive nature of this agreement is limited to the duration of the performance and it is expected that the performer will enter into other similar agreements with other customers.

9. **COMPLIANCE WITH LOCAL, STATE AND FEDERAL LAWS** – Company shall comply with all applicable laws, ordinances, and codes of the federal, state, and local governments.

10. **INSURANCE REQUIREMENTS:** Company shall provide all required COG certificates of coverage and all renewals throughout the duration of the Project. For each policy except Workers' Compensation protection, Company shall name COG as an additional insured and shall provide that the policy requires the insurance carrier to notify COG a minimum of thirty days (30) in advance of cancellation of all or part of the policy. All insurance policies are to be issued by an insurance company authorized to do business in the State of Texas and using an insurance company with an A.M. Best rating of B+ or better. All subcontractors utilized must also comply with these specifications as if they were the winning proposer. Specific details of coverage limits and conditions are listed below.

Required Insurance:

- a. Commercial general liability insurance, naming the COG as an additional insured and as certificate holder, and waiving subrogation per the contractual requirements of this project. Limits are to be equal to or greater than:

\$2,000,000 general liability (includes products and personal, etc.)

\$1,000,000 fire damage

\$1,000,000 automobile damage

\$500,000 workers compensation employers' liability

Statutory limits for workers compensation

Insurance coverage shall be on an "**occurrence basis**"

11. **APPROPRIATIONS:** The obligations of COG to make payment under this Agreement are expressly subject to appropriations by the COG of funds that are lawfully available to be applied to such purpose.

12. **FORCE MAJEURE:** In the event that the performance of any of the covenants of this agreement shall be prevented by an act of God, pandemic, the acts and regulations of public authorities, or labor disputes, acts of the public enemy, acts of superior governmental authority, or other circumstances, or cause beyond their or its reasonable control, COG and Company shall be respectively relieved of their obligations hereunder with respect to the performance(s) so

prevented. In the above-mentioned event, Company grants COG the right to reschedule the performance(s) under the same terms and conditions of this Agreement.

13. **INDEMNIFICATION**. FOR CONSIDERATION RECEIVED, Company shall, to the extent allowable, indemnify, save and hold COG of Galveston harmless, including COG's officers, agents, employees and servants, from any claims, actions, lawsuits, proceedings, damages, loss, judgments, liabilities or expense on account of damage to property and injuries, including death, to the extent caused by any negligent act, intentional tort, intellectual property infringement, or failure to pay a subcontractor or supplier of Company or those acting under Company's supervision or control. Company shall not be responsible, however, for any loss, damage, liability or expense on account of damage to property and injuries, including death, by which may arise from the negligence of COG. Company shall comply with the requirements of all current applicable laws, rules and regulations and shall indemnify and hold harmless COG and its agency members from and against the failure to comply with those laws, and shall assume full responsibility for payments of Federal, State and local taxes on contributions imposed or required under the Social Security, worker's compensation and income tax laws.

14. **COPYRIGHT**: The Company specifically warrants and represents that all copyrighted material to be performed has been licensed or authorized by the copyright owners or their representatives. The Company indemnifies COG for any copyright infringement and any expenses that may result from such copyright infringement during or as the result of the performance(s).

15. **TAXES** - Company will pay when due all taxes or assessments applicable to Company. Company will comply with the provisions of all Applicable Laws related to taxes and taxing authority.

16. **ASSIGNMENT**: Neither party hereto may assign its rights or delegate its obligations hereunder without the written consent of the other party.

17. **NO WAIVER**: The failure of any party to enforce any provision of this Agreement shall not be construed as a waiver or limitation of that party's right to subsequently enforce that or any other provision of this Agreement.

18. **SEVERABILITY CLAUSE**: The phrases, clauses, sentences, paragraphs or sections of these conditions are severable. If any phrase, clause, sentence, paragraph, or section of these conditions should be declared invalid by the final decree or judgment of any court of competent jurisdiction, such invalidity shall not affect any of the remaining phrases, clauses, sentences, paragraphs and sections of these conditions.

19. **ATTORNEY'S FEES**: In the event there is a dispute concerning this Agreement, each party shall be responsible for its own costs and expenses including attorneys' fees and court costs incurred in the course of any dispute, mediation, or legal proceeding.

20. **APPLICABLE LAW, VENUE, AND JURISDICTION**: This Agreement shall be construed under and in accordance with the laws of the State of Texas, with jurisdiction in the courts of the State of Texas and venue in Galveston, County regardless of where the obligations of the parties were performed. By execution of this Agreement, the parties agree to subject themselves to the jurisdiction of the Courts of the State of Texas in all matters relating to or arising out of this Agreement or the Work.

21. **NOTICES** - All notices required or permitted under this Agreement shall be in writing and shall be deemed given when delivered in person or three days after deposit in the United States Mail, postage prepaid, addressed to the party's address reflected at the end of this Agreement. A party's notice address may be changed from time to time by that party's providing written notice to the other. A copy of the notice to COG shall be sent to:

City Attorney
City of Galveston
823 Rosenberg, Suite 203
P. O. Box 779
Galveston, Texas 77553

Crescent Electric
1319 First St, L
La Marque, TX, 77568

22. **Dispute Resolution** - Parties shall attempt to resolve any payment disputes within sixty (60) days or the matter may be submitted to mediation.

Nothing herein shall hinder, prevent, or be construed as a waiver of COG's right to seek redress on any disputed matter in a court of competent jurisdiction.

Nothing herein shall waive or be construed as a waiver of the COG's sovereign immunity.

Neither the occurrence of an event giving rise to a breach of contract claim nor the pendency of a claim constitute grounds for the suspension of performance by Company, in whole or in part. COG and Company agree that any periods set forth in this Agreement for notice and cure of defaults are not waived, delayed, or suspended.

Except in the case of a breach of contract or termination for cause, in the event there is a dispute concerning this Agreement, each party shall be responsible for its own costs and expenses including attorneys' fees and court costs incurred in the course of any dispute, mediation, or legal proceeding.

23. **TERMINATION:** This Agreement may be terminated prior to completion of the Work by either party upon 10 days' written notice to the other. If, through any cause, Company shall fail to fulfill in a timely and proper manner his/her obligations under this Agreement, COG shall thereupon have the right to terminate this Agreement by giving written notice to Company of such termination and specifying the effective date thereof, at least five days before the effective date of such termination. In the event of early termination, COG shall pay Company for all work performed and expenses incurred to the date specified in the notice of termination. Notwithstanding the above, Company shall not be relieved of liability to COG for damages sustained by COG by virtue of any breach of the Agreement by Company or its subordinates and COG may withhold any payments to Company for the purpose of set-off until such time as the exact amount of damages due COG from Company is determined.

24. **BINDING EFFECT** - This Agreement is binding upon and inures to the benefit of the parties and their respective permitted successors and assigns.

25. **EXHIBITS** - All Exhibits attached hereto are incorporated herein by reference for all purposes as part of this Agreement. To the extent of any conflict, this Agreement will control.

Exhibit 1 – Scope of Work and Compensation

Exhibit 2 – Appendix A – Proposal Document

Appendix B – Conflict of Interest Form Executed

Appendix C – House Bill 89, 13, 19 Verification Form Executed

Appendix D – Property Tax Statement Executed

Appendix E – Nepotism Statement Executed

Appendix F – Non-Collusion Statement Executed

Appendix G – Document 00435 Debarment

Exhibit 3 – Federal Clauses Executed

26. **ENTIRE AGREEMENT:** This Agreement supersedes all prior agreements, written or oral, between Company and COG and constitutes the entire and integrated Agreement and understanding between the parties with respect to the subject matter of the Agreement. This Agreement may only be amended by a written instrument signed by both parties.

IN WITNESS WHEREOF, the parties have executed this Agreement in duplicate on the day and year first above written.

CITY OF GALVESTON, TEXAS

Company

DocuSigned by:
By: Daniel J. Buckley; For
88F9068399D042A...

City Manager

DocuSigned by:
By: Andy Mack
F456047F8C8C4E6...

ATTEST:

DocuSigned by:
Janelle Williams
F12776E17F29488...

City Secretary



APPROVED AS TO FORM

DocuSigned by:
Donna Fairweather for
6A59EBFC33E64A8...

City Attorney

6. Scope of Services

GENERAL INFORMATION

The City of Galveston is seeking a contractor to provide the services of licensed electricians to perform electrical repairs, installations, and maintenance for the City of Galveston on an "as needed" basis. Any estimates referenced are estimates only and are given for the information of bidder and for the purpose of bid evaluation. They do not indicate the actual amount which will be spent, since such expenditures will depend upon requirements which develop during the contractual period. The successful contractor shall provide all labor, materials and equipment required to complete all assigned jobs.

- Contractor shall be able to start all non-emergency projects within ten (10) working days after notification from City of Galveston's Authorized Representative.
- The contractor shall complete each non-emergency job within the time specified in their project estimate. For the purpose of this bid, an emergency is defined as any condition which is a threat to health, welfare, or the safety of people and/or property or a condition that will affect an essential service(s) as determined by City of Galveston.
- Contractor shall provide twenty-four hour call answering services.
- Service shall be made available to the City 365 days per year, 24 hours per day.
- Regular service shall be made available between the hours of 8:00 a.m. to 5:00 p.m., Monday through Friday, excluding City of Galveston recognized holidays.
- All work requested outside of these times shall be considered EMERGENCY after hour's service and shall be charges at rate specified in the bid.
- Contractors shall employ at least one (1) Master Electrician and three (3) full time journeymen electricians with at least five (5) years' experience in the trade.
- Contractors shall also employ apprentice electricians to assist in various tasks. To meet this requirement these employees shall have been employed by the bidder at least six months prior to submission of a bid. Bidders shall provide, with their bid, resumes and license numbers of all personnel available for this contract.

EQUIPMENT

Contractor shall own and have in good to excellent condition, all equipment necessary to perform the described services and related tasks.

ESTIMATES

Contractor shall provide written "not to exceed" estimates on all projects except on emergencies. This estimate shall include the estimated number of hours, hourly rates, number and types of employees required, estimated material costs and number of calendar days required for project completion. Contractor shall respond to requests for estimates for non-emergency work within two (2) days and provide written estimates within five (5) days. It shall be the contractor's responsibility to ensure they have all information to prepare accurate estimates.

Competitive Pricing: It is the City of Galveston intent to obtain the best quality work at a competitive price. If, in the City of Galveston's opinion, an estimate is deemed unreasonable, the City will inform the contractor. If an agreement on a competitive price cannot be reached, the City reserves the right to use an alternate contractor for the requested work.

SAFETY

All contractors and subcontractors performing service for the City are required and shall

comply with all Occupational Safety and Health Administration (OSHA), State and County Safety and Occupational Health Standards and any other applicable rules and regulations. All contractors shall be held responsible for the safety for their employees and any unsafe acts or conditions that may cause injury or damage to any persons or property within and around the work site.

PERMITS

It shall be the responsibility of the Contractor(s) to comply with City Ordinances by securing the necessary permits.

WORKMANSHIP AND INSPECTION

All work under the resulting contract shall be performed in a skillful and workmanlike manner. The City may, in writing, require the Contractor to remove any employee from work that the City desires. Furthermore, the City may, from time to time make inspections of the work performed under this contract. Any inspections that indicate defectives will be the responsibility of the Contractor to correct at no additional cost to the City of Galveston from any responsibility regarding defective parts, equipment or service, or from any required local city inspections.

CLEAN UP

The Contractors shall be responsible for removing all debris from the site and the cleaning of affected areas. Contractor shall keep the premises free of debris and unusable materials resulting from their work and as work progresses, or upon request by City's representative, shall remove such debris and materials from the property. The Contractor shall leave all affected areas as they were prior to beginning work.

WARRANTY/GUARANTEEE

Parts, replacement parts, and fixtures shall be new and warranted for at least ninety (90) days. All labor for repairs shall have a one (1) year labor warranty.

REPAIR WORK

Repair work shall be performed at the site, unless by the nature of the required repairs, it would be necessary to move a component to the Contractor's shop for repair. If unit is to be down for more than twelve (12) hours, the City will be advised and informed of the nature of repairs. The City reserves the right to outsource services and/or parts if downtime exceeds twelve hours, or the vendor is unable to obtain replacement parts/ components within a twelve (12) hour period.

PROTECTION OF PROPERTY

The contractor shall make necessary repairs in such a manner that does not damage property. In the event damage occurs to property by reason of any repairs or installations performed under the Contract, the Contractor shall replace or repair the same at no cost to the City. If damage caused by the Contractor has to be repaired or replaced by the City, the cost of such work shall be deducted from the monies due the Contractor.

UNSATISFACTORY WORK

In the event the work performance of the Contractor is unsatisfactory, the Contractor will be notified by the City and be given seven (7) calendar days to correct the work. There will be no cost to City of Galveston for any re-works.

EMPLOYEES OF THE CONTRACTOR

No one except authorized employees of the Contractor will be allowed on the job premises. Contractors' employees are NOT to be accompanied in their work area by acquaintances,

family members, or assistants of any other person unless said person is an authorized employee of the Contractor.

RETENTION OF RECORDS

The contractor agrees to retain all financial books, records, and other documents relevant to this Contract for seven (7) years after final payment or until after the resolution of any audit questions which could be more than seven (7) years, whichever is longer. The Department, Federal or State auditors or any other persons duly authorized by the Department shall have full access to, and the right to examine, copy and make use of any and all said materials.

CITY OF GALVESTON RESPONSIBILITIES

The City of Galveston representative shall be responsible for:

1. Instructing the contractor of what the work consists of and materials/equipment which may be needed when applicable.
2. Approving a record of time and materials used for the job and state on the work ticket that they have inspected and accepted the work performed and the date.
3. In the event overtime is required to complete the work before the fact, approval shall be obtained from the City of Galveston Authorized Representative.

CONTROL, SUPERVISION, AND APPROVAL AUTHORITY

Unless otherwise provided by specific provisions under this agreement, contractor operations and activities related and provided for in this agreement will be under the general supervision of the Authorized Representative of the Facilities Department who for the purposes of this contract is:

Charles Kenworthy
Director of Facilities
City of Galveston
823 Rosenberg
Galveston, Texas 77550

PAYMENT TERMS AND DELIVERABLES

Payment will be made after satisfactory completion of the work. Submit invoices, along with signed work report "Record of Time and Material" for each job performed to City of Galveston, Accounts Payable Department, AccountsPayable@galvestontx.gov

CONTRACTORS QUALIFICATIONS AND DELIVERABLES

Each bidder is requested to submit with their bid, the following information:

1. A statement showing that the bidder has the experience and ability to perform, and has been actively and regularly engaged in the business performing the type of work described herein for a minimum of two (2) years.
2. A list of three (3) satisfactory references, including the names, telephone numbers, and other contact information of a contact person for each including a description of the job.
3. Evidence of any and all licenses held by all employees necessary to perform the work as

required in this solicitation.

PROTECTION OF MATERIALS

It shall be the sole responsibility of the Contractor performing services to safeguard their own materials, tools, and equipment. The City of Galveston shall not assume responsibility for vandalism and/or theft of materials, tools and/or equipment.

ELECTRICAL SERVICES
PRICING FORM

ITEM NUMBER	DESCRIPTION	QUANTITY	CATALOG #	TRIP/TRAVEL CHARGES PER HOUR	UNIT PRICE (per hour labor)	EXTENDED PRICE (trip charge plus unit price)
1	ELECTRICIAN REGULAR TIME	1 HR		- 0 -	70.00	70.00
2	ELECTRICIAN EMERGENCY/OT	1 HR		- 0 -	100.00	100.00
3	JOURNEYMAN REGULAR TIME	1 HR		- 0 -	70.00	70.00
4	JOURNEYMAN EMERGENCY/OT	1 HR		- 0 -	100.00	100.00
5	APPRENTICE REGULAR TIME	1 HR		- 0 -	30.00	30.00
6	APPRENTICE EMERGENCY/OT	1 HR		- 0 -	45.00	45.00
7	SERVICE TRUCK	1 HR		- 0 -	- 0 -	- 0 -
8	BUCKET TRUCK	1 HR		- 0 -	50.00	50.00
9	TRENCHING EQUIPMENT	1 HR		- 0 -	25.00	25.00
10	BACKHOE OPERATOR	1 HR		- 0 -	50.00	50.00
11	PERCENTAGE MARK UP ON MATERIALS					18 %

*** ALL EQUIPMENT IS ASSUMED COMPANY OWNED

Appendix A – Bid Document

Submittal Checklist: (To determine validity of bid)

- Appendix A (pages 10 through 19) must be included in the bid submittal.
- Appendix B – G (pages 20 through 26) all forms must be complete and included in the bid submittal.

By checking the below box(es), you are acknowledging the contents of the document(s) relating to the listed appendices, and agreeing to their terms:

- | | |
|--|--|
| <input checked="" type="checkbox"/> Appendix B – Conflict of Interest | <input checked="" type="checkbox"/> Appendix E – Nepotism Statement |
| <input checked="" type="checkbox"/> Appendix C – House Bill 13,19, 89 Verification | <input checked="" type="checkbox"/> Appendix F – Non-Collusion Statement |
| <input checked="" type="checkbox"/> Appendix D – Property Tax Statement | <input checked="" type="checkbox"/> Appendix G – Certification Regarding Debarment |
| <input checked="" type="checkbox"/> Appendix J – Scope of Work | <input checked="" type="checkbox"/> Appendix K – Federal Clauses |

- Appendix J (pages 30 through 34) must be included in the bid submittal.
- Appendix K (pages 35 through 39) all pages, including signature page must be included in submittal.

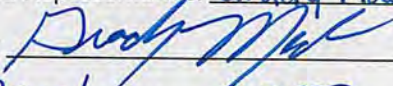
All bids submitted to the City of Galveston shall include this page with the submitted Bid.			
Bid Number:	22-02		
Project Title:	Electrical Services		
Submittal Deadline:	10:00 A.M.(CST), Monday, March 21, 2022		
Submit Electronically: Upload Submittal Here			
Bidder Information:			
Bidder's Legal Name:	Crescent Engineering Co.Inc. dba Crescent Electric		
Address:	1319 First St.		
City, State & Zip	La Marque, Tx 77568		
Federal Employers Identification Number #	76-0252028		
Phone Number:	409-935-2416	Fax Number:	409-935-2428
E-Mail Address:	CrescentElectric@comcast.net		
Bidder Authorization			
I, the undersigned, have the authority to execute this Bid in its entirety as submitted and enter into a contract on behalf of the Bidder.			
Printed Name and Position of Authorized Representative: <u>Grady Mack, President</u>			
Signature of Authorized Representative: <u></u>			
Signed this <u>14</u> (day) of <u>March</u> (month), <u>2022</u> (year)			

Appendix A – Bid Document (continued)**I. REQUIRED BID INFORMATION. IN ORDER FOR A BID TO BE CONSIDERED COMPLETE, AND TO BE EVALUATED FOR A CONTRACT AWARD BY THE CITY, BIDDER MUST SUBMIT ALL OF THE FOLLOWING INFORMATION****1. Proposed Products and/or Services**

- A. Product or Service Description: Bidders should utilize this section to describe the technical aspects, capabilities, features and options of the service or product and/or service proposed in accordance with the required Scope of Services as identified in Appendix J. Promotional literature, brochures, or other technical information may be used.
- B. Additional Hardware Descriptions: Bidders should also include in this section a detailed description of what additional hardware and/or software, if any, would be required by the City in order to fully utilize the goods and/or services proposed.
- C. Material Safety Data Sheets (MSDS): If applicable, the successful Bidder shall provide the City with applicable MSDS documentation as required by applicable laws and regulations.
- D. Guarantees and Warranties: Each Bidder shall submit a complete copy of any warranties or guarantees provided by the manufacturer or Bidder with the Bid submitted.
- E. Project Schedule/Delivery Date: Bidder must provide a project schedule noting all projected completion dates for segments of the Project, from start-up to completion, and all delivery dates for goods covered by the BID. The Bid Document must show the number of days required to deliver and install the product or equipment after the receipt of the City's Purchase Order.

2. Cost of Proposed Products and/or Services

- A. Pricing: Pricing shall reflect the full Scope of Services defined herein, inclusive of all associated cost for delivery, labor, insurance, taxes, overhead, and profit.
- B. Schedule of Pricing: Please see Appendix J.

3. Bidder's Experience / Staff

- A. Project Team: Identify all members of the Bidder's team (including both team members and management) who will be providing any services proposed and include information which details their experience.
- B. Removal or Replacement of Staff: If an assigned staff person must be removed or replaced for any reason, the replacement person must be approved by City prior to joining the project.
- C. Business Establishment: State the number of years the Bidder's business has been established and operating. If Bidder's business has changed names or if the principals operating the business operate any similar businesses under different names, or have operated any other businesses or changed the legal status or form of the business within the last five (5) years, all names, of predecessor business names, affiliated entities, and previous business entities operated by the principals, if different than present, must be provided;

State the number of years' experience the business has: 76; and the number of employees: 55.

D. Project Related Experience: All Bids must include detailed information that details the Bidder's experience and expertise in providing the requested services that demonstrates the Bidder's ability to logically plan and complete the requested project.

4. References

Bidder shall provide three (3) references where Bidder has performed similar to or the same types of services as described herein. Bidder shall provide references not affiliated with the City of Galveston, or any of its employees.

Reference #1:

Client / Company Name: <u>Galveston College</u>	
Contact Name: <u>Tim Setzer</u>	Contact Title:
Phone: <u>409-763-6551</u>	Email: <u>TSetzer@gc.edu</u>
Date and Scope of Services Provided: <u>Electrical maintenance, trouble shooting and new installations.</u>	

Reference #2:

Client / Company Name: <u>City of Texas City</u>	
Contact Name: <u>Jack Haralson</u>	Contact Title:
Phone: <u>409-739-9471</u>	Email: <u>Jharalson@texascitytx.gov</u>
Date and Scope of Services Provided: <u>Electrical maintenance, trouble shooting, and new installations.</u>	

Reference #3:

Client / Company Name: <u>County of Galveston</u>	
Contact Name: <u>Lee Crowder</u>	Contact Title:
Phone: <u>409-682-3690</u>	Email: <u>Lee.Crowder@co.galveston.tx.us</u>
Date and Scope of Services Provided: <u>Electrical maintenance, trouble shooting, and new installations.</u>	

5. Trade Secrets and/or Confidential Information

Trade Secrets and/or Confidential Information: This bid ___ (does) (does not) contain trade secrets and/or confidential information. If applicable, describe such trade secrets and confidential information, and the basis for your assertion that such material qualifies for legal protection from disclosure.

6. Federal, State and/or Local Identification Information

- A. Centralized Master Bidders List registration number: 67014
- B. Prime contractor HUB / MWBE registration number: N/A

- C. An individual Bidder acting as a sole proprietor must also enter the Bidder's Social Security Number: # _____ - _____ - _____.
- D. Dun and Bradstreet Number - Data Universal Numbering System (DUNS):
825579311
- E. All vendors contracting with the City of Galveston may be required to register, or have an active registration with the System for Award Management (SAM.gov). Registration is free. The System for Award Management (SAM) is the official registration required prior to bidding on a contract with any federal government agency, including local governments who receive federal funds. Registration must be completed prior to contract award by City Council. Registering online is accomplished on the SAM website here: <https://www.sam.gov/portal/SAM/##11#1>.

7. Cooperative Governmental Purchasing Notice

Other governmental entities maintaining interlocal agreements with the City, may desire, but are not obligated, to purchase goods and services defined in this BID from the successful Bidder. All purchases by governmental entities, other than the City, will be billed directly to and paid by that governmental entity. The City will not be responsible for another governmental entity's debts. Each governmental entity will place their own orders with the successful Bidder and be responsible for ensuring full compliance with the BID specifications. Prior to other governmental entities placing orders, the City will notify the successful Bidder of their intent.

Please indicate below if you will permit other governmental entities to purchase from your agreement with the City.

Yes, Others can purchase **No, Only the City can purchase.**

8. Term of Contract and Option to Extend: Any contract resulting from this BID shall be effective for three (3) years upon execution by the City of Galveston. The City anticipates that contract shall be renewed pursuant to the availability of funds and at the discretion of the City. The following clauses shall be included in the contract:

- A. Option Clause: It is agreed that City will have the option to extend the contract for up to two (2) additional years, in one-year intervals. Any contract resulting from this Bid shall automatically renew for successive one-year periods under the existing terms and conditions, unless either party gives the other party written notice of non-renewal at least 30 days prior to such renewal date. Total term of the contract **will not** exceed five (5) years. The Option to Extend will not be considered if funding is unavailable or if the contractor's past performance is not within the industry standard.
- B. Escalation Clause: Should market conditions prevail which dictate an increase, the successful contractor may submit documentation requesting permission to increase pricing no later than 30 days after receiving notice from the City of its intent to extend the agreement. Escalation may only occur at the time of renewal and only upon securing the approval of the City in writing. Requests for price adjustments must be solely for the purpose of accommodating an increase in the contractor's cost, not profits.

Vendors shall show in this quote their anticipated percent of escalation if/when the option to extend is exercised. The percent quoted will be a maximum. In addition, the percentage proposed will be a factor in determining the best value to the City. It is the average price over the period of the contract that will be the price factor considered in the evaluation of

this quote. Quotes in which negative or no escalation is shown will be considered as 0% escalation.

- C. Price Increases Upon Extension: If approved by the City, the Contractor shall modify the rates charged by the Contractor to reflect any changes shown in the comparative statement delivered to the City. The maximum increase allowed under this provision shall be four percent (4%) per year. The City of Galveston will not accept, or agree, to any escalation clause higher than four percent (4%) per year. If an escalation clause of greater than the maximum allowed by the City, as stated previously, is inserted in the blanks below, the City will consider that the amount of escalation is 0%. The City shall have authority, in its reasonable discretion, to determine the validity of any change in Contractor's rates. City cannot exercise the Option to Extend with any price increases unless the Vendor completes the section of the Quote requesting anticipated percentage of annual escalation. The escalation time frame will be determined by the City's Fiscal Year which begins in October and ends the following September. (example: FY 2017 October 1, 2016 – September 30, 2017)

FIRST ADDITIONAL YEAR (FY 2025) ESCALATION 2.5%
SECOND ADDITIONAL YEAR (FY 2026) ESCALATION..... 2.5%

9. Emergency Business Services Contact Notice

During a natural disaster, or homeland security event, there may be a need for the City of Galveston to access your business for products or services after normal business hours and/or holidays. The City may request City employee pick up or vendor delivery of product or services.

For this purpose, a primary and secondary emergency contact name and phone number are required. It is critical the vendor's emergency contact information remains current. City shall be contacted by E-mail with any change to a contact name or phone number of these emergency contacts. Updates may be emailed to **purchasing@galvestontx.gov**.

All products or services requested during an emergency event are to be supplied as per the established contract prices, terms and conditions. The vendor shall provide the fee (pricing) for an after-hours emergency opening of the business, if any. In general, orders will be placed using a City of Galveston procurement card (Master Card) or City issued Purchase Order. The billing is to include the emergency opening fee, if applicable.

The contractor shall provide the names, phone numbers and fee (pricing), if any, for an after-hours emergency opening of the business listed below.

Business Name: Crescent Engineering Co. Inc. dba Crescent Electric

Contract #: 22-02

Description: Electrical Services

Primary Contact (Name): Grady Mack

Primary Contact Phone Numbers: Home: N/A Cell: 409-682-1244

Secondary Contact (Name): Carlisle Smith

Secondary Contact Phone Numbers: Home: N/A Cell: 832-614-5870

After Hours emergency opening fee, if applicable: \$ -0-

II. CONTRACT TERMS AND CONDITIONS. EXCEPT WHERE BIDDER MAKES SPECIFIC EXCEPTION IN THE SUBMITTED BID, ANY CONTRACT RESULTING FROM THIS BID WILL CONTAIN THE FOLLOWING TERMS AND CONDITIONS, WHICH BIDDER HEREBY ACKNOWLEDGES, AND TO WHICH BIDDER AGREES BY SUBMITTING A BID.

1. Delivery of Products and/or Services

- A. Payment Terms: Unless otherwise specified in the Scope of Services or otherwise agreed to in writing by the City, payment terms for the City are Net 30 days upon receipt of invoice. Refer to Texas Local Government Code 2251, Payment for Goods and Services. Otherwise known as the Prompt Payment Act. Send all invoices to City of Galveston Attention: Accounts Payable, PO Box 779, Galveston, Texas 77553 or email: accountspayable@galvestontx.gov. See Appendix I for ACH Payment Information, if you elect to receive your payments according to Appendix I, fill out the form and return with your documents.
- B. Warranty of Products and Services: All products furnished under this contract shall be warranted to be merchantable and good quality and fit for the purposes intended as described in this Bid, to the satisfaction of City and in accordance with the specifications, terms, and conditions of the Scope of Services, and all services performed shall be warranted to be of a good and workmanlike quality, in addition to, and not in lieu of, any other express written warranties provided.
- C. Late Delivery or Performance: If Bidder fails to deliver acceptable goods or services within the timeframes established in the Project Schedule, the City shall be authorized to purchase the goods or services from another source and assess any increase in costs to the defaulting Bidder, who agrees to pay such costs within ten days of invoice.
- D. FOB (delivery charges): All products offered shall be FOB final destination, with all delivery charges to be prepaid by the Bidder. The City does not accept C.O.D. or collect shipments. The contract price shall include all charges, including delivery, installation and set-up fees. All packing, crating, or other debris resulting from the delivery or set-up of the commodity purchased shall be removed and properly disposed by the successful Bidder at no additional cost to the City.
- E. Excess or Incorrect Commodities: Products or materials delivered in error or in excess of the quantity ordered shall be returned at the successful Bidder's expense, unless otherwise agreed to in writing by the City.
- F. Title to Goods and Risk of Loss: For goods to be provided by Bidders hereunder, if any, the title and risk of loss of the goods shall not pass to City until City actually receives, takes possession, and accepts the goods and the installation of such goods, has tested the system, and determined that it is in good and acceptable working order.
- G. Force Majeure: If by reason of Force Majeure either party shall be rendered unable, wholly or in part, to carry out its responsibilities under this contract by any occurrence by reason of Force Majeure, then the party unable to carry out its responsibility shall give the other

party notice and full particulars of such Force Majeure in writing within a reasonable time after the occurrence of the event, and such notice shall suspend the party's responsibility for the continuance of the Forced Majeure claimed, but for no longer period. Force Majeure means acts of God, floods, hurricanes, tropical storms, tornadoes, earthquakes, or other natural disasters, acts of public enemy, acts of terrorism, sovereign conduct, riots, civil commotion, strikes or lockouts, and other causes that are not occasioned by either Party's conduct which by the exercise of due diligence the party is unable to overcome and which substantially interferes with operations.

- H. Liquidated Damages: This Section is intentionally left blank.
- I. Change Orders: per Texas Local Government Code - Sec. 252.048. CHANGE ORDERS.
- (a) If changes in plans or specifications are necessary after the performance of the contract is begun or if it is necessary to decrease or increase the quantity of work to be performed or of materials, equipment, or supplies to be furnished, the governing body of the municipality may approve change orders making the changes.
- (b) The total contract price may not be increased because of the changes unless additional money for increased costs is appropriated for that purpose from available funds or is provided for by the authorization of the issuance of time warrants.
- (c) If a change order involves a decrease or an increase of \$50,000 or less, the governing body may grant general authority to an administrative official of the municipality to approve the change orders.
- (c-1) If a change order for a public works contract in a municipality with a population of 300,000 or more involves a decrease or an increase of \$100,000 or less, or a lesser amount as provided by ordinance, the governing body of the municipality may grant general authority to an administrative official of the municipality to approve the change order.
- (d) The original contract price may not be increased under this section by more than 25 percent. The original contract price may not be decreased under this section by more than 25 percent without the consent of the contractor.

2. **Miscellaneous**

- A. Independent Contractor: Bidder agrees that Bidder and Bidder's employees and agents have no employer-employee relationship with City. Bidder agrees that if Bidder is selected and awarded a contract, City shall not be responsible for the Federal Insurance Contribution Act (FICA) payments, Federal or State unemployment taxes, income tax withholding, Workers Compensation Insurance payments, or any other insurance payments, nor will City furnish any medical or retirement benefits or any paid vacation or sick leave.
- B. Assignments: The rights and duties awarded the successful Bidder shall not be assigned to another without the written consent of the Purchasing Supervisor. Such consent shall not relieve the assigner of liability in the event of default by the assignee.
- C. Liens: Bidder shall indemnify and save harmless the City against any and all liens and encumbrances for all labor, goods, and services which may be provided to the City by Bidder or Bidder's vendor(s), and if the City requests, a proper release of all liens or satisfactory evidence of freedom from liens shall be delivered to the City.
- D. Gratuities / Bribes: Bidder certifies that no bribes in the form of entertainment, gifts, or otherwise, were offered or given by the successful Bidder, or its agent or representative, to any City officer, employee or elected representative, with respect to this BID or any contract with the City, and that if any such bribe is found to have been made this shall be grounds for voiding of the contract

- E. Financial Participation: Bidder certifies that it has not received compensation from the City to participate in preparing the specifications or BID on which the Bid is based and acknowledges that this contract may be terminated and/or payment withheld if this certification is inaccurate.
- F. Required Licenses: Bidder certifies that he holds all licenses required by the State of Texas for a provider of the goods and/or services described by the Scope of Services herein.
- G. Authority to Submit Bid and Enter Contract: The person signing on behalf of Bidder certifies that the signer has authority to submit the Bid on behalf of the Bidder and to bind the Bidder to any resulting contract.
- H. Authority to Enter Contract – City: The City Manager is the only person authorized to execute contracts on behalf of the City. All signature pages must include "approved as to form" and be signed by the City Attorney before the City Manager will execute the contract. Neither department heads nor elected officials are authorized to sign any binding contracts or agreements prior to being properly placed on the City Councils agenda and approved in an open meeting. Department heads and other elected officials are not authorized to enter into any type of agreement or contract on behalf of the City of Galveston. Only the City Manager may enter into a contract on behalf of the City of Galveston as authorized by City Council and the City Charter. Additionally, department heads and other elected officials are not authorized to agree to any type of supplemental agreements or contracts for goods or services. Supplemental agreements are subject to review by the City's Legal Department prior to being signed by the City Manager, (City's authorized representative).
- I. Compliance with Applicable Law: Bidder agrees that the contract will be subject to, and Bidder will strictly comply with, all applicable federal, state, and local laws, ordinances, rules, and regulations.
- J. Non-Discrimination: During the performance of this contract, the contractor agrees as follows: (1) The contractor will not discriminate against any employee or applicant for employment because of race, age, disability, color, religion, sex, or national origin. The contractor will take affirmative action to ensure that applicants and employees are not discriminated against on the basis of race, age, disability, color, religion, sex or national origin. Such action shall include, but not be limited to the following: employment, upgrading, demotion, or transfer; recruitment or recruitment advertising; layoff or termination; rates of pay or other forms of compensation; and selection for training, including apprenticeship. The contractor agrees to post in conspicuous places, available to employees and applicants for employment, notices to be provided by the contracting officer setting forth the provisions of this nondiscrimination clause. (2) The contractor will, in all solicitations or advertisements for employees placed by or on behalf of the contractor, state that all qualified applicants will receive consideration for employment without regard to race, age, disability, color, religion, sex or national origin. (3) In the event of the contractor's noncompliance with the nondiscrimination clauses of this contract or with any of the said rules, regulations, or orders, this contract may be canceled, terminated, or suspended in whole or in part and the contractor may be declared ineligible for further Government contracts or federally assisted construction contracts in accordance with procedures authorized in Executive Order 11246 of September 24, 1965, and such other sanctions as may be imposed and remedies invoked as provided in Executive Order 11246 of September 24, 1965, or by rule, regulation, or order of the Secretary of Labor, or as otherwise provided by law.

3. **Financial Responsibility Provisions**

- A. Insurance: The Bidder, consistent with its status as an independent contractor, shall carry, and shall require any of its subcontractors to carry, at least the following insurance in such

form, with such companies, and in such amounts (unless otherwise specified in the Scope of Services, Appendix J) as City may require, naming the City of Galveston as the additional insured:

- i. Worker's Compensation and Employer's Liability insurance, including All States Endorsement, to the extent required by federal law and complying with the laws of the State of Texas;
- ii. Commercial General Liability insurance for at least One Million Dollars (\$1,000,000) on a per occurrence basis, with a Two Million (\$2,000,000) aggregate. Blanket Contractual Liability, Broad Form Property Damage, Personal Injury, Completed Operations/Products Liability, Premises Liability, Medical Payments, and Broad Form General Liability Endorsements;
- iii. Comprehensive Automobile Liability insurance covering all owned, non-owned or hired automobiles to be used by the Contractor, with coverage at the minimum State of Texas requirements;
- iv. Professional Liability, Errors and Omissions in an amount to be determined in the Scope of Services.

Insurance coverage shall be on an "occurrence basis"

- B. **Indemnification:** In Accordance with State Law, the contractor agrees to indemnify, save, and hold harmless the City of Galveston, Texas, its employees, officials, and agents from any and all claims, actions, damages, lawsuits, proceedings, judgements, or liabilities, for personal injury, death, or property damage resulting from the acts or omissions of anyone under the contractor's supervision or control.

In the event of any cause of action or claim asserted by a party to this agreement or any third party, the City will provide the contractor with timely notice of such claim, dispute or notice. Thereafter, the contractor shall at its own expense, faithfully and completely defend and protect the City against any and all liabilities arising from this claim, cause of action, or notice.

- i. Indemnity for Intellectual Property: Bidder hereby warrants that the use or sale of the products, materials and services delivered hereunder will not infringe on the rights of any trade secrets, patent, copyright, registered trademark, or other intellectual property by right covering such materials and the successful Bidder agrees to indemnify and hold harmless the City for any and all costs, expenses, judgments, and damages which the City may have to pay or incur.

- C. Bond Requirements: This section is intentionally left blank.

Appendix B – Form CIQ

INFORMATION REGARDING VENDOR CONFLICT OF INTEREST QUESTIONNAIRE

WHO: The following persons must file a Conflict of Interest Questionnaire with the City if the person has an employment or business relationship with an officer of the City that results in taxable income exceeding \$2,500 during the preceding twelve – month period, or an officer or a member of the officer's family has accepted gifts with an aggregate value of more than \$250 during the previous twelve – month period and the person engages

in any of the following actions:

1. contracts or seeks to contract for the sale or purchase of property, goods or services with the City, including any of the following:
 - a. written and implied contracts, utility purchases, purchase orders, credit card purchases and any purchase of goods and services by the City;
 - b. contracts for the purchase or sale of real property, personal property including an auction of property;
 - c. tax abatement and economic development agreements;
2. submits a bid to sell goods or services, or responds to a request for proposal for services;
3. enters into negotiations with the City for a contract; or
4. applies for a tax abatement and/or economic development incentive that will result in a contract with the City

THE FOLLOWING ARE CONSIDERED OFFICERS OF THE CITY:

1. Mayor and City Council Members;
2. City Manager;
3. Board and Commission members and appointed members by the Mayor and City Council;
4. Directors of 4A and 4B development corporations;
5. The executive directors or managers of 4A and 4B development corporations; and
6. Directors of the City of Galveston who have authority to sign contracts on behalf of the City.

EXCLUSIONS: A questionnaire statement need not be filed if the money paid to a local government official was a political contribution, a gift to a member of the officer's family from a family member; a contract or purchase of less than \$2,500 or a transaction at a price and subject to terms available to the public; a payment for food, lodging, transportation or entertainment; or a transaction subject to rate or fee regulation by a governmental entity or agency.

WHAT: A person or business that contracts with the City or who seeks to contract with the City must file a "Conflict of Interest Questionnaire" (FORM CIQ) which is available online at www.ethics.state.tx.us and a copy of which is attached to this guideline. The form contains mandatory disclosures regarding "employment or business relationships" with a municipal officer. Officials may be asked to clarify or interpret various portions of the questionnaire.

WHEN: The person or business must file:

1. the questionnaire – no later than seven days after the date the person or business begins contract discussions or negotiations with the municipality, or submits an application, responds to a request for proposals or bids, correspondence, or other writing related to a potential contract or agreement with the City; and
2. an updated questionnaire – within seven days after the date of an event that would make a filed questionnaire incomplete or inaccurate.

It does not matter if the submittal of a bid or proposal results in a contract. The statute requires a vendor to file a FORM CIQ at the time a proposal is submitted or negotiations commence.

WHERE: The vendor or potential vendor must mail or deliver a completed questionnaire to the Finance Department. *The Finance Department is required by law to post the statements on the City's website.*

ENFORCEMENT: Failure to file a questionnaire is a Class C misdemeanor punishable by a fine not to exceed \$500. It is an exception to prosecution that the person files a FORM CIQ not later than seven business days after the person received notice of a violation.

NOTE: The City does not have a duty to ensure that a person files a Conflict of Interest Questionnaire.

CONFLICT OF INTEREST QUESTIONNAIRE

FORM CIQ

For vendor or other person doing business with local governmental entity

This questionnaire reflects changes made to the law by H.B. 1491, 80th Leg., Regular Session.

**OFFICE
USE
ONLY**

This questionnaire is being filed in accordance with Chapter 176, Local Government Code by a person who has a business relationship as defined by Section 176.001(1-a) with a local governmental entity and the person meets requirements under Section 176.006(a).

Date
Received

By law this questionnaire must be filed with the records administrator of the local governmental entity not later than the 7th business day after the date the person becomes aware of facts that require the statement to be filed. See Section 176.006, Local Government Code.

A person commits an offense if the person knowingly violates Section 176.006, Local Government Code. An offense under this section is a Class C misdemeanor.

1. Name of person who has a business relationship with local governmental entity.

N/A

2. Check this box if you are filing an update to a previously filed questionnaire.

(The law requires that you file an updated completed questionnaire with the appropriate filing authority not later than the 7th business day after the date the originally filed questionnaire becomes incomplete or inaccurate.)

3. Name of local government officer with whom filer has employment or business relationship.

Name of Officer

This section (item 3 including subparts A, B, C & D) must be completed for each officer with whom the filer has an employment or other business relationship as defined by Section 176.001(1-a), Local Government Code. Attach additional pages to this Form CIQ as necessary.

- A. Is the local government officer named in this section receiving or likely to receive taxable income, other than investment income, from the filer of the questionnaire?
 Yes No
- B. Is the filer of the questionnaire receiving or likely to receive taxable income, other than investment income, from or at the direction of the local government officer named in this section AND the taxable income is not received from the local governmental entity?
 Yes No
- C. Is the filer of this questionnaire employed by a corporation or other business entity with respect to which the local government officer serves as an officer or director, or holds an ownership of 10 percent or more?
 Yes No
- D. Describe each employment or business relationship with the local government officer named in this section.

4. none
Signature of person doing business with the governmental entity

3-8-22
Date

Adopted 06-29-2007

THIS DOCUMENT MUST BE COMPLETED AND SUBMITTED AS IT IS A PART OF THE BID PACKAGE AS MENTIONED IN SECTION 6B OF THE BID.

CONFLICT OF INTEREST QUESTIONNAIRE

For vendor doing business with local governmental entity

A complete copy of Chapter 176 of the Local Government Code may be found at <http://www.statutes.legis.state.tx.us/Docs/LG/htm/LG.176.htm>. For easy reference, below are some of the sections cited on this form.

Local Government Code § 176.001(1-a): "Business relationship" means a connection between two or more parties based on commercial activity of one of the parties. The term does not include a connection based on:

- (A) a transaction that is subject to rate or fee regulation by a federal, state, or local governmental entity or an agency of a federal, state, or local governmental entity;
- (B) a transaction conducted at a price and subject to terms available to the public; or
- (C) a purchase or lease of goods or services from a person that is chartered by a state or federal agency and that is subject to regular examination by, and reporting to, that agency.

Local Government Code § 176.003(a)(2)(A) and (B):

(a) A local government officer shall file a conflicts disclosure statement with respect to a vendor if:

(2) the vendor:

(A) has an employment or other business relationship with the local government officer or a family member of the officer that results in the officer or family member receiving taxable income, other than investment income, that exceeds \$2,500 during the 12-month period preceding the date that the officer becomes aware that

(i) a contract between the local governmental entity and vendor has been executed;

or

(ii) the local governmental entity is considering entering into a contract with the vendor;

(B) has given to the local government officer or a family member of the officer one or more gifts that have an aggregate value of more than \$100 in the 12-month period preceding the date the officer becomes aware that:

(i) a contract between the local governmental entity and vendor has been executed; or

(ii) the local governmental entity is considering entering into a contract with the vendor.

Local Government Code § 176.006(a) and (a-1)

(a) A vendor shall file a completed conflict of interest questionnaire if the vendor has a business relationship with a local governmental entity and:

(1) has an employment or other business relationship with a local government officer of that local governmental entity, or a family member of the officer, described by Section 176.003(a)(2)(A);

(2) has given a local government officer of that local governmental entity, or a family member of the officer, one or more gifts with the aggregate value specified by Section 176.003(a)(2)(B), excluding any gift described by Section 176.003(a-1); or

(3) has a family relationship with a local government officer of that local governmental entity.

(a-1) The completed conflict of interest questionnaire must be filed with the appropriate records administrator not later than the seventh business day after the later of:

(1) the date that the vendor:

(A) begins discussions or negotiations to enter into a contract with the local governmental entity; or

(B) submits to the local governmental entity an application, response to a request for proposals or bids, correspondence, or another writing related to a potential contract with the local governmental entity; or

(2) the date the vendor becomes aware:

(A) of an employment or other business relationship with a local government officer, or a family member of the officer, described by Subsection (a);

(B) that the vendor has given one or more gifts described by Subsection (a); or

(C) of a family relationship with a local government officer.

Appendix C - House Bills 13, 19 & 89 Verification

Pursuant to Senate Bill 13 of the 87th regular Texas Legislature session:

Verification Regarding Boycotting Energy Companies – Pursuant to Chapter 2274, Texas Government Code, Contractor verifies (1) it does not boycott energy companies, and (2) it will not boycott energy companies during the term of this Agreement. Contractor acknowledges this Agreement may be terminated and payment withheld if this verification is inaccurate. (Note: This provision only applies in a contract that (1) has a value of \$100,000 or more that is to be paid wholly or partly from public funds and (2) is with a for-profit entity, not including a sole proprietorship, that has ten (10) or more full-time employees.)

Pursuant to Senate Bill 19 of the 87th regular Texas Legislature session:

Discrimination Against Firearm Entities – In accordance with Texas Government Code Chapter 2274, Contractor verifies that it does not have a practice, policy, guidance or directive that discriminates against a firearm entity or firearm trade association; and will not discriminate during the term of the contract against a firearm entity or firearm trade association. This section only applies if: (i) Contractor has ten (10) or more full-time employees and (ii) this Agreement has a value of \$100,000 or more to be paid under the terms of this Agreement; and does not apply: (i) if Contractor is a sole proprietor, a non-profit entity, or a governmental entity; (ii) to a contract with a sole-source provider; or (iii) to a contract for which none of the bids from a company were able to provide the required certification.

Pursuant to Sections 2270.001, 2270.002, 808.001, Texas Government Code:

1. "Boycott Israel" means refusing to deal with, terminating business activities with, or otherwise taking any action that is intended to penalize, inflict economic harm on, or limit commercial relations specifically with Israel, or with a person or entity doing business in Israel or in an Israeli-controlled territory, but does not include an action made for ordinary business purposes; and
2. "Company" has the meaning assigned by Section 808.001, except that the term does not include a sole proprietorship.
3. Section only applies to a contract that is between a governmental entity and a company with 10 or more full-time employees; and has a value of \$100,000 or more that is to be paid wholly or partly from public funds of the governmental entity.

I, Grady Mack (Person name), the undersigned representative of (Company or

Business Name) Crescent Engineering Co Inc. dba Crescent Electric, (hereinafter referred to as Company)

being an adult over the age of eighteen (18) years of age, do hereby depose and verify under oath that the company named-above, under the provisions of Subtitle F, Title 10, Government Code Chapter 2270; depose and verify under oath that the Company, under the provisions of Subtitle A, Title 8, Government Code, is amended by adding Chapter 809; do hereby depose and verify under oath that the Company, under the provisions of Subtitle F, Title 10, Government Code, is amended by adding Chapter 2274 will not discriminate and/or boycott any of these provisions outlined and defined in House Bills 13, 19 and 89.

3-14-22

DATE

SIGNATURE OF COMPANY REPRESENTATIVE

THIS DOCUMENT MUST BE COMPLETED AND SUBMITTED AS IT IS A PART OF THE SOLICITATION PACKAGE AS MENTIONED IN SECTION 6B OF THE BID.

Appendix D – Property Tax Statement

**FAILURE TO COMPLETE THIS ATTACHMENT SHALL RESULT IN THE PURCHASING SUPERVISOR
DEEMING YOUR BID OR PROPOSAL
"NON-RESPONSIVE."**

The City of Galveston, Texas has adopted the following policy:

The City of Galveston will not do business with any person or business that owes delinquent property taxes to the City.

Please indicate whether you or your company, owe delinquent property taxes to the City whether an assumed name, partnership, corporation, or any other legal form.

I do not owe the City property taxes that are delinquent.

I owe City property taxes that are delinquent on property located at

Grady Mack

Bidder's Printed or Typed Name



Bidder's Signature

~~3-22~~ 3-4-22

Date

**THIS DOCUMENT MUST BE COMPLETED, SIGNED, AND SUBMITTED AS IT IS A
PART OF THE BID PACKAGE AS MENTIONED IN SECTION 6B OF THE BID.**

Appendix E – Nepotism Statement

FAILURE TO COMPLETE THIS ATTACHMENT SHALL RESULT IN THE PURCHASING SUPERVISOR DEEMING YOUR BID OR PROPOSAL "NON-RESPONSIVE."

The Bidder or Proposer or any officer, if the Bidder or Proposer is other than an individual, shall state whether Bidder or Proposer has a relationship, either by blood or marriage, with any official or employee of the City of Galveston by completing the following:

If the Bidder or Proposer is an individual:

I am not related by blood or marriage to any official or employee of the City of Galveston.

I am related by blood or marriage to the following official(s) or employee(s) of the City of Galveston

Name and title of City Official

Or employee: _____

Relationship: _____

If the Bidder or Proposer is **NOT** an individual:

The officers of the company submitting this bid or proposal are not related by blood or marriage to any official or employee of the City of Galveston.

The officers of the company submitting this bid are related by blood or marriage to the following official(s) or employee(s) of the City of Galveston.

Name and title of officer: Grady Mack - President

Employee and title of City Official or Employee: n/a

Relationship: None

THIS DOCUMENT MUST BE COMPLETED AND SUBMITTED AS IT IS A PART OF THE BID PACKAGE AS MENTIONED IN SECTION 6B OF THE BID.

Appendix F – Non-Collusion Statement

THE UNDERSIGNED AFFIRM THAT THEY ARE DULY AUTHORIZED TO EXECUTE THIS CONTRACT, THAT THIS COMPANY, FIRM, PARTNERSHIP OR INDIVIDUAL HAS NOT PREPARED THIS BID IN COLLUSION WITH ANY OTHER BIDDER, AND THAT THE CONTENTS OF THIS BID AS TO PRICES, TERMS OR CONDITIONS OF SAID BID HAVE NOT BEEN COMMUNICATED BY THE UNDERSIGNED NOR BY ANY EMPLOYEE OR AGENT TO ANY OTHER PERSON ENGAGED IN THIS TYPE OF BUSINESS PRIOR TO THE OFFICIAL OPENING OF THIS BID.

VENDOR Crescent Engineering Co. Inc. dba Crescent Electric

ADDRESS 1319 First St., La Marque, TX 77568

PHONE 409-935-2416

FAX 409-935-2428

BIDDER (SIGNATURE) 

BIDDER (PRINTED NAME) Grady Mack

POSITION WITH COMPANY President

SIGNATURE OF COMPANY OFFICIAL AUTHORIZING THIS BID 

COMPANY OFFICIAL (PRINTED NAME) Grady Mack

OFFICIAL POSITION President

THIS DOCUMENT MUST BE COMPLETED, SIGNED, AND SUBMITTED AS IT IS A PART OF THE BID PACKAGE AS MENTIONED IN SECTION 6B OF THE BID.

Appendix G – Document 00435 The City of Galveston, Texas

**DOCUMENT 00435, REQUIRED BY ALL BIDDERS WHO WILL RECEIVE FEDERAL FUNDS IN
PAYMENT OF PROCUREMENT.**

BIDDER'S CERTIFICATION REGARDING DEBARMENT, SUSPENSION, INELIGIBILITY AND VOLUNTARY EXCLUSION (49 CFR PART 29)

The undersigned certifies, by submission of this Bid or acceptance of this contract, that neither Contractor nor its principals is presently debarred, suspended, proposed for debarment, declared ineligible, or voluntarily excluded from participation in this transaction by any Federal department or agency. Bidder agrees that by submitting this proposal that Bidder will include this clause without modification in all lower tier transactions, solicitations, proposals, contracts, and subcontracts. Where the Bidder or any lower tier participant is unable to certify to this statement, that participant shall attach an explanation to this document.

Certification-the above information is true and complete to the best of my knowledge and belief.

Grady Mack
(Printed or typed Name of Signatory)

(Signature)

3-14-22
(Date)

NOTE: The penalty for making false statements in offers is prescribed in **18 U.S.C. 1001**

END OF DOCUMENT 00435-FAA

**THIS DOCUMENT MUST BE COMPLETED, SIGNED, AND SUBMITTED AS IT IS A
PART OF THE BID PACKAGE AS MENTIONED IN SECTION 6B OF THE BID.**

APPENDIX K – FEDERAL CLAUSES

The following, federally mandated, clauses require acknowledgement of the offeror and are considered part of the contract between the City of Galveston and the awarded vendor. Any offeror that does not acknowledge the clauses below shall be considered non-responsive and will not be considered for award.

1. **NO GOVERNMENTAL OBLIGATION TO THIRD PARTIES:** The Owner and Contractor acknowledge and agree that, notwithstanding any concurrence by the Federal Government in or approval of the solicitation or award of the underlying contract, absent the express written consent by the Federal Government, the Federal Government is not a party to this contract and shall not be subject to any obligations or liabilities to the Owner, Contractor, or any other party (whether or not a party to that contract) pertaining to any matter resulting from the underlying contract.
2. **PROGRAM FRAUD AND FALSE OR FRAUDULENT STATEMENTS AND RELATED ACTS:** Contractor acknowledges that the provisions of the Program Fraud Civil Remedies Act of 1986, as amended, 31 U.S.C. § 3801 *et seq.*, "Administrative Remedies for False Claims and Statements," apply to its actions pertaining to this Project. Upon execution of the underlying contract, the Contractor certifies or affirms the truthfulness and accuracy of any statement it has made, it makes, it may make, or causes to be made, pertaining to the underlying contract for which this contract work is being performed. In addition to other penalties that may be applicable, the Contractor further acknowledges that if it makes, or causes to be made, a false, fictitious, or fraudulent claim, statement, submission, or certification, the Federal Government reserves the right to impose the penalties of the Program Fraud Civil Remedies Act of 1986 on the Contractor to the extent the Federal Government deems appropriate.
3. **ACCESS TO RECORDS AND REPORTS:** The contractor agrees to provide (insert name of state agency or local or Indian tribal government), (insert name of recipient), the FEMA Administrator, the Comptroller General of the United States, or any of their authorized representatives access to any books, documents, papers, and records of the Contractor which are directly pertinent to this contract for the purposes of making audits, examinations, excerpts, and transcriptions. The Contractor agrees to permit any of the foregoing parties to reproduce by any means whatsoever or to copy excerpts and transcriptions as reasonably needed. The contractor agrees to provide the FEMA Administrator or his authorized representatives access to construction or other work sites pertaining to the work being completed under the contract."
4. **EQUAL EMPLOYMENT OPPORTUNITY:** The contractor will not discriminate against any employee or applicant for employment because of race, color, religion, sex, or national origin. The contractor will take affirmative action to ensure that applicants are employed, and that employees are treated during employment without regard to their race, color, religion, sex, or national origin. Such action shall include, but not be limited to the following: Employment, upgrading, demotion, or transfer; recruitment or recruitment advertising; layoff or termination; rates of pay or other forms of compensation; and selection for training, including apprenticeship. The contractor agrees to post in conspicuous places, available to employees and applicants for employment, notices to be provided setting forth the provisions of this nondiscrimination clause. The contractor will, in all solicitations or advertisements for employees placed by or on behalf of the contractor, state that all qualified applicants will

receive considerations for employment without regard to race, color, religion, sex, or national origin. The contractor will send to each labor union or representative of workers with which he has a collective bargaining agreement or other contract or understanding, a notice to be provided advising the said labor union or workers' representatives of the contractor's commitments under this section, and shall post copies of the notice in conspicuous places available to employees and applicants for employment. The contractor will comply with all provisions of Executive Order 11246 of September 24, 1965, and of the rules, regulations, and relevant orders of the Secretary of Labor. The contractor will furnish all information and reports required by Executive Order 11246 of September 24, 1965, and by rules, regulations, and orders of the Secretary of Labor, or pursuant thereto, and will permit access to his books, records, and accounts by the administering agency and the Secretary of Labor for purposes of investigation to ascertain compliance with such rules, regulations, and orders. In the event of the contractor's noncompliance with the nondiscrimination clauses of this contract or with any of the said rules, regulations, or orders, this contract may be canceled, terminated, or suspended in whole or in part and the contractor may be declared ineligible for further Government contracts or federally assisted construction contracts in accordance with procedures authorized in Executive Order 11246 of September 24, 1965, and such other sanctions as may be imposed and remedies invoked as provided in Executive Order 11246 of September 24, 1965, or by rule, regulation, or order of the Secretary of Labor, or as otherwise provided by law. The vendor will include the portion of the sentence immediately preceding paragraph (1) and the provisions of paragraphs (1) through (7) in every subcontract or purchase order unless exempted by rules, regulations, or orders of the Secretary of Labor issued pursuant to section 204 of Executive Order 11246 of September 24, 1965, so that such provisions will be binding upon each subcontractor or vendor. The contractor will take such action with respect to any subcontract or purchase order as the administering agency may direct as a means of enforcing such provisions, including sanctions for noncompliance: Provided, however, That in the event a contractor becomes involved in, or is threatened with, litigation with a subcontractor or vendor as a result of such direction by the administering agency the contractor may request the United States to enter into such litigation to protect the interests of the United States."

5. **GOVERNMENT-WIDE SUSPENSION AND DEBARMENT:** This contract is a covered transaction for purposes of 2 C.F.R. pt. 180 and 2 C.F.R. pt. 3000. As such the contractor is required to verify that none of the contractor, its principals (defined at 2 C.F.R. § 180.995), or its affiliates (defined at 2 C.F.R. § 180.905) are excluded (defined at 2 C.F.R. § 180.940) or disqualified (defined at 2 C.F.R. § 180.935). The contractor must comply with 2 C.F.R. pt. 180, subpart C and 2 C.F.R. pt. 3000, subpart C and must include a requirement to comply with these regulations in any lower tier covered transaction it enters into. This certification is a material representation of fact relied upon by (insert name of subrecipient). If it is later determined that the contractor did not comply with 2 C.F.R. pt. 180, subpart C and 2 C.F.R. pt.3000, subpart C, in addition to remedies available to (name of state agency serving as recipient and name of subrecipient), the Federal Government may pursue available remedies, including but not limited to suspension and/or debarment. The bidder or proposer agrees to comply with the requirements of 2 C.F.R. pt. 180, subpart C and 2 C.F.R. pt. 3000, subpart C while this offer is valid and throughout the period of any contract that may arise from this offer. The bidder or proposer further agrees to include a provision requiring such compliance in its lower tier covered transactions.

6. **CONTRACT WORK HOURS AND SAFETY STANDARDS ACT:**

1. **Overtime requirements** - No contractor or subcontractor contracting for any part of the contract work which may require or involve the employment of laborers or mechanics shall require or permit any such laborer or mechanic in any workweek in which he or she is employed on such work to work in excess of forty hours in such workweek unless such laborer or mechanic receives compensation at a rate not less than one and one-half times the basic rate of pay for all hours worked in excess of forty hours in such workweek.
2. **Violation; liability for unpaid wages; liquidated damages** - In the event of any violation of the clause set forth in paragraph (1) of this section the contractor and any subcontractor responsible therefor shall be liable for the unpaid wages. In addition, such contractor and subcontractor shall be liable to the United States for liquidated damages. Such liquidated damages shall be computed with respect to each individual laborer or mechanic, including watchmen and guards, employed in violation of the clause set forth in paragraph (1) of this section, in the sum of \$10 for each calendar day on which such individual was required or permitted to work in excess of the standard workweek of forty hours without payment of the overtime wages required by the clause set forth in paragraph (1) of this section.
3. **Withholding for unpaid wages and liquidated damages** - The Owner shall, upon its own action or upon written request of an authorized representative of the Department of Labor, withhold or cause to be withheld, from any moneys payable on account of work performed by the contractor or subcontractor under any such contract or any other Federal contract with the same prime contractor, or any other federally-assisted contract subject to the Contract Work Hours and Safety Standards Act, which is held by the same prime contractor, such sums as may be determined to be necessary to satisfy any liabilities of such contractor or subcontractor for unpaid wages and liquidated damages as provided in the clause set forth in paragraph (2) of this section.
4. **Subcontracts** - Contractor or subcontractor shall insert in any subcontracts the clauses set forth in paragraphs (1) through (4) of this section and also a clause requiring the subcontractors to include these clauses in any lower tier subcontracts. The prime contractor shall be responsible for compliance by any subcontractor or lower tier subcontractor with the clauses set forth in paragraphs (1) through (4) of this section.

7. **LOBBYING:**

Byrd Anti-Lobbying Amendment, 31 U.S.C. § 1352 (as amended)

Contractors who apply or bid for an award of \$100,000 or more shall file the required certification. Each tier certifies to the tier above that it will not and has not used Federal appropriated funds to pay any person or organization for influencing or attempting to influence an officer or employee of any agency, a member of Congress, officer or employee of Congress, or an employee of a member of Congress in connection with obtaining any Federal contract, grant, or any other award covered by 31 U.S.C. § 1352. Each tier shall also disclose any lobbying with non-Federal funds that takes place in connection with obtaining any Federal award. Such disclosures are forwarded from tier to tier up to the recipient.

APPENDIX A, 44 C.F.R. PART 18 – CERTIFICATION REGARDING LOBBYING

Certification for Contracts, Grants, Loans, and Cooperative Agreements
(To be submitted with each bid or offer exceeding \$100,000)

The undersigned [Contractor] certifies, to the best of his or her knowledge, that:

- 1) No Federal appropriated funds have been paid or will be paid, by or on behalf of the undersigned, to any person for influencing or attempting to influence an officer or employee of an agency, a Member of Congress, an officer or employee of Congress, or an employee of a Member of Congress in connection with the awarding of any Federal contract, the making of any Federal grant, the making of any Federal loan, the entering into of any cooperative agreement, and the extension, continuation, renewal, amendment, or modification of any Federal contract, grant, loan, or cooperative agreement.
- 2) If any funds other than Federal appropriated funds have been paid or will be paid to any person for influencing or attempting to influence an officer or employee of any agency, a Member of Congress, an officer or employee of Congress, or an employee of a Member of Congress in connection with this Federal contract, grant, loan, or cooperative agreement, the undersigned shall complete and submit Standard Form - LLL, "Disclosure Form to Report Lobbying," in accordance with its instructions.
- 3) The undersigned shall require that the language of this certification be included in the award documents for all subawards at all tiers (including subcontracts, subgrants and contracts under grants, loans, and cooperative agreements) and that all subrecipients shall certify and disclose accordingly.

This certification is a material representation of fact upon which reliance was placed when this transaction was made or entered into. Submission of this certification is a prerequisite for making or entering into this transaction imposed by 31, U.S.C. § (as amended by the Lobbying Disclosure Act of 1995). Any person who fails to the required certification shall be subject to a civil penalty of not less than \$10,000 and not more than \$100,000 for each such failure.

The Contractor certifies or affirms by signing this contract the truthfulness and accuracy of each statement of its certification and disclosure, if any. In addition, Contractor understands and agrees that the provisions of 31 U.S.C. § 3801 *et seq* apply to this certification and disclosure, if any.

8. **CLEAN AIR 42 U.S.C. § 7401 et seq.** Contractor agrees to comply with all applicable standards, orders or regulations issued pursuant to the Clean Air Act, as amended, 42 U.S.C. §§ 7401 *et seq*. The Contractor agrees to report each violation to the Owner and understands and agrees that the Owner will, in turn, report each violation as required to assure notification to the State of Texas, Federal Emergency Management Agency, and the appropriate Environmental Protection Agency Regional Office.

Contractor also agrees to include these requirements in each subcontract exceeding \$150,000 financed in whole or in part with Federal assistance provided by FEMA.

9. **CLEAN WATER REQUIREMENTS 33 U.S.C. 1251 et seq.** Contractor agrees to comply with all applicable standards, orders or regulations issued pursuant to the Federal Water Pollution Control Act, as amended, 33 U.S.C. 1251 *et seq*. Contractor agrees to report each violation to the Owner and understands and agrees that the Owner will, in turn, report each violation as required to assure notification to the State of Texas, Federal Emergency Management Agency, and the appropriate Environmental Protection Agency Regional Office. Contractor also agrees to include

these requirements in each subcontract exceeding \$150,000 financed in whole or in part with Federal assistance provided by FEMA.

10. PROCUREMENT OF RECOVERED MATERIALS 42 U.S.C 6962:

(1) In the performance of this contract, the Contractor shall make maximum use of products containing recovered materials that are EPA- designated items unless the product cannot be acquired—

- (i) Competitively within a timeframe providing for compliance with the contract performance schedule;
- (ii) Meeting contract performance requirements; or
- (iii) At a reasonable price.

(2) Information about this requirement, along with the list of EPA-designate items, is available at EPA's Comprehensive Procurement Guidelines web site,

<https://www.epa.gov/smm/comprehensive-procurement-guideline-cpg-program>.

11. DEPARTMENT OF HOMELAND SECURITY SEAL, LOGO, AND FLAGS: By signing this contract, the contractor agrees it shall not use the DHS seal(s), logos, crests, or reproductions of flags or likenesses of DHS agency officials without specific FEMA pre- approval.

12. COMPLIANCE WITH FEDERAL LAW, REGULATIONS, AND EXECUTIVE ORDERS: This is an acknowledgement that FEMA financial assistance will be used to fund the contract only. The contractor will comply will all applicable federal law, regulations, executive orders, FEMA policies, procedures, and directives.

I, Grady Mack (printed name), the undersigned, do hereby acknowledge, and agree to comply, with the above statements for the entire length of any agreement with the City of Galveston, Texas.

Signature of Authorized Company Representative

3-14-22
Date

THIS DOCUMENT MUST BE SIGNED AND SUBMITTED AS IT IS A PART OF THE BID PACKAGE AS MENTIONED IN SECTION 6B OF THE BID.

CERTIFICATE OF INTERESTED PARTIES

FORM 1295

1 of 1

Complete Nos. 1 - 4 and 6 if there are interested parties.
Complete Nos. 1, 2, 3, 5, and 6 if there are no interested parties.

OFFICE USE ONLY CERTIFICATION OF FILING

Certificate Number:
2022-870248

Date Filed:
04/07/2022

Date Acknowledged:

1 Name of business entity filing form, and the city, state and country of the business entity's place of business.
Crescent Electric
La Marque, TX United States

2 Name of governmental entity or state agency that is a party to the contract for which the form is being filed.
CITY OF GALVESTON

3 Provide the identification number used by the governmental entity or state agency to track or identify the contract, and provide a description of the services, goods, or other property to be provided under the contract.
COG-CON-22-857
Electrical Contracting

4	Name of Interested Party	City, State, Country (place of business)	Nature of interest (check applicable)	
			Controlling	Intermediary

5 Check only if there is NO Interested Party.

6 UNSWORN DECLARATION

My name is Tara Broze, and my date of birth is [REDACTED]

My address is 5603 Ecret Dr. Dickinson Tx 77539 USA
(street) (city) (state) (zip code) (country)

I declare under penalty of perjury that the foregoing is true and correct.

Executed in Galveston County, State of Texas, on the 7th day of April, 2022.
(month) (year)

Tara Broze
Signature of authorized agent of contracting business entity
(Declarant)



CERTIFICATE OF LIABILITY INSURANCE

DATE (MM/DD/YYYY)

5/28/2021

THIS CERTIFICATE IS ISSUED AS A MATTER OF INFORMATION ONLY AND CONFERS NO RIGHTS UPON THE CERTIFICATE HOLDER. THIS CERTIFICATE DOES NOT AFFIRMATIVELY OR NEGATIVELY AMEND, EXTEND OR ALTER THE COVERAGE AFFORDED BY THE POLICIES BELOW. THIS CERTIFICATE OF INSURANCE DOES NOT CONSTITUTE A CONTRACT BETWEEN THE ISSUING INSURER(S), AUTHORIZED REPRESENTATIVE OR PRODUCER, AND THE CERTIFICATE HOLDER.

IMPORTANT: If the certificate holder is an ADDITIONAL INSURED, the policy(ies) must be endorsed. If SUBROGATION IS WAIVED, subject to the terms and conditions of the policy, certain policies may require an endorsement. A statement on this certificate does not confer rights to the certificate holder in lieu of such endorsement(s).

PRODUCER Texas First Insurance 7900 Emmett F. Lowry Expy Texas City TX 77591	CONTACT NAME: Patsy Beall ACSR	PHONE (A/C, No, Ext): (409) 934-8000	FAX (A/C, No): (409) 935-1883
	E-MAIL ADDRESS: patsy.beall@texasfirst.insurance		
INSURED CBJ Group, Inc. (see additional NAMED Insured form attach P.O. Box 36 La Marque TX 77568-0036	INSURER(S) AFFORDING COVERAGE		NAIC #
	INSURER A: Service Lloyds Insurance Co		43389
	INSURER B:		
	INSURER C:		
	INSURER D:		
	INSURER E:		

COVERAGES CERTIFICATE NUMBER: 21-22 Rowl Certs REVISION NUMBER:

THIS IS TO CERTIFY THAT THE POLICIES OF INSURANCE LISTED BELOW HAVE BEEN ISSUED TO THE INSURED NAMED ABOVE FOR THE POLICY PERIOD INDICATED. NOTWITHSTANDING ANY REQUIREMENT, TERM OR CONDITION OF ANY CONTRACT OR OTHER DOCUMENT WITH RESPECT TO WHICH THIS CERTIFICATE MAY BE ISSUED OR MAY PERTAIN, THE INSURANCE AFFORDED BY THE POLICIES DESCRIBED HEREIN IS SUBJECT TO ALL THE TERMS, EXCLUSIONS AND CONDITIONS OF SUCH POLICIES. LIMITS SHOWN MAY HAVE BEEN REDUCED BY PAID CLAIMS.

INSR LTR	TYPE OF INSURANCE	ADDL INSD	SUBR WVD	POLICY NUMBER	POLICY EFF (MM/DD/YYYY)	POLICY EXP (MM/DD/YYYY)	LIMITS
	COMMERCIAL GENERAL LIABILITY <input type="checkbox"/> CLAIMS-MADE <input type="checkbox"/> OCCUR GEN'L AGGREGATE LIMIT APPLIES PER: <input type="checkbox"/> POLICY <input type="checkbox"/> PRO-JECT <input type="checkbox"/> LOC OTHER:						EACH OCCURRENCE \$ DAMAGE TO RENTED PREMISES (Ea occurrence) \$ MED EXP (Any one person) \$ PERSONAL & ADV INJURY \$ GENERAL AGGREGATE \$ PRODUCTS - COMPIOPAGG \$ \$
	AUTOMOBILE LIABILITY <input type="checkbox"/> ANY AUTO <input type="checkbox"/> ALL OWNED AUTOS <input type="checkbox"/> HIRED AUTOS <input type="checkbox"/> SCHEDULED AUTOS <input type="checkbox"/> NON-OWNED AUTOS						COMBINED SINGLE LIMIT (Ea accident) \$ BODILY INJURY (Per person) \$ BODILY INJURY (Per accident) \$ PROPERTY DAMAGE (Per accident) \$ \$
	UMBRELLA LIAB EXCESS LIAB <input type="checkbox"/> OCCUR <input type="checkbox"/> CLAIMS-MADE DED RETENTION \$						EACH OCCURRENCE \$ AGGREGATE \$ \$
A	WORKERS COMPENSATION AND EMPLOYERS' LIABILITY ANY PROPRIETOR/PARTNER/EXECUTIVE OFFICER/MEMBER EXCLUDED? (Mandatory in NH) If yes, describe under DESCRIPTION OF OPERATIONS below		Y/N <input type="checkbox"/> N/A	SL1CHC0327601	6/3/2021	6/3/2022	<input checked="" type="checkbox"/> PER STATUTE <input type="checkbox"/> OTH-ER E.L. EACH ACCIDENT \$ 1,000,000 E.L. DISEASE - EA EMPLOYEE \$ 1,000,000 E.L. DISEASE - POLICY LIMIT \$ 1,000,000

DESCRIPTION OF OPERATIONS / LOCATIONS / VEHICLES (ACORD 101, Additional Remarks Schedule, may be attached if more space is required)

The Workers' Compensation policy includes a blanket automatic waiver of subrogation endorsement that provides waiver of subrogation wording to the certificate holder. This applies, as permitted by law but only under the circumstances stated in the policy, when there is a written contract between the named insured and the certificate holder that requires such status. USL&H Coverage applies.

CERTIFICATE HOLDER**CANCELLATION**

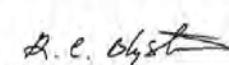
City of Galveston PO Box 779 Galveston, TX 77553	SHOULD ANY OF THE ABOVE DESCRIBED POLICIES BE CANCELLED BEFORE THE EXPIRATION DATE THEREOF, NOTICE WILL BE DELIVERED IN ACCORDANCE WITH THE POLICY PROVISIONS. AUTHORIZED REPRESENTATIVE G Blystone CIC/PATSY 
--	---

Additional Named Insureds

Other Named Insureds

Crescent Electric	Corporation, Insured Multiple Names
Crescent Engineering, Inc.	Corporation, Insured Multiple Names
Industrial I & E	Corporation, Insured Multiple Names
Industrial Instrumentation & Electrical, Inc.	Corporation, Insured Multiple Names



AGENCY CUSTOMER ID: 229-859-4

LOC #: _____

ADDITIONAL REMARKS SCHEDULEPage 1 of 1

AGENCY FEDERATED MUTUAL INSURANCE COMPANY		NAMED INSURED CRESCENT ENGINEERING, CRESCENT ELECTRIC, INDUSTRIAL I & E PO BOX 36 LA MARQUE, TX 77568	
POLICY NUMBER SEE CERTIFICATE # 29.0		EFFECTIVE DATE: SEE CERTIFICATE # 29.0	
CARRIER SEE CERTIFICATE # 29.0	NAIC CODE		

ADDITIONAL REMARKS

THIS ADDITIONAL REMARKS FORM IS A SCHEDULE TO ACORD FORM,

FORM NUMBER: 25 FORM TITLE: CERTIFICATE OF LIABILITY INSURANCE

ADDITIONAL NAMED INSUREDS INCLUDE
 CBJ GROUP INC, INDUSTRIAL INSTRUMENTATION & ELECTRICAL

THE CERTIFICATE HOLDER IS AN ADDITIONAL INSURED SUBJECT TO THE CONDITIONS OF THE ADDITIONAL INSURED - OWNERS, LESSEES OR CONTRACTORS - AUTOMATIC STATUS WHEN REQUIRED IN CONSTRUCTION AGREEMENT WITH YOU ENDORSEMENT FOR GENERAL LIABILITY.

THE CERTIFICATE HOLDER IS AN ADDITIONAL INSURED SUBJECT TO THE CONDITIONS OF THE ADDITIONAL INSURED BY CONTRACT ENDORSEMENT FOR BUSINESS AUTO LIABILITY.

INSURANCE PROVIDED BY THE GENERAL LIABILITY COVERAGE IS PRIMARY AND NONCONTRIBUTORY OVER OTHER INSURANCE. GENERAL LIABILITY CONTAINS A WAIVER OF TRANSFER OF RIGHTS OF RECOVERY AGAINST OTHERS TO US (WAIVER OF SUBROGATION) - AUTOMATIC ENDORSEMENT

BUSINESS AUTO LIABILITY CONTAINS A WAIVER OF SUBROGATION IN FAVOR OF THE CERTIFICATE HOLDER SUBJECT TO THE CONDITIONS OF THE BLANKET WAIVER OF TRANSFER OF RIGHTS OF RECOVERY ENDORSEMENT.

INSTALLATION FLOATER IS INCLUDED WITH A LIMIT OF \$250,000 IN ANY ONE OCCURRENCE AND \$250,000 AT ANY ONE PREMISES OF INSTALLATION OR TEMPORARY STORAGE LOCATION.

UMBRELLA FOLLOWS FORM.

THIS ENDORSEMENT CHANGES THE POLICY. PLEASE READ IT CAREFULLY.

ADDITIONAL INSURED BY CONTRACT ENDORSEMENT

This endorsement modifies insurance provided under the following:

BUSINESS AUTO COVERAGE PART

With respect to coverage provided by this endorsement, the provisions of the Coverage Form apply unless modified by the endorsement.

- A. WHO IS AN INSURED for "bodily injury" and "property damage" liability is amended to include:
Any person or organization other than a joint venture, for which you have agreed by written contract to procure bodily injury or property damage "auto" liability insurance arising out of operation of a covered "auto" with your permission. However, this additional insurance does not apply to:
- (1) The owner or anyone else from whom you hire or borrow a covered "auto". This exception does not apply if the covered "auto" is a "trailer" connected to a covered "auto" you own.
 - (2) Your "employee" if the covered "auto" is owned by that "employee" or a member of his or her household.
 - (3) Someone using a covered "auto" while he or she is working in a business of selling, servicing, repairing, parking or storing "autos" unless that business is yours.
 - (4) Anyone other than your "employees", partners (if you are a partnership), members (if you are a limited liability company), or a lessee or borrower or any of their "employees", while moving property to or from a covered "auto".
 - (5) A partner (if you are a partnership), or a member (if you are a limited liability company) for a covered "auto" owned by him or her or a member of his or her household.
- B. The coverage extended to any additional insured by this endorsement is limited to, and subject to all terms, conditions, and exclusions of the Coverage Part to which this endorsement is attached.
- In addition, coverage shall not exceed the terms and conditions that are required by the terms of the written agreement to add any insured, or to procure insurance.
- C. The limits of insurance applicable to such insurance shall be the lesser of the limits required by the agreement between the parties, or the limits provided by this policy.
- D. Additional exclusions. The insurance afforded to any person or organization as an insured under this endorsement does not apply:
1. To "loss" which occurs prior to the date of your contract with such person or organization;
 2. To "loss" arising out of the sole negligence of any person or organization that would not be an insured except for this endorsement.
 3. To "loss" for any leased or rented "auto" when the lessor or his or her agent takes possession of the leased or rented "auto" or the policy period ends, whichever occurs first.

Includes copyrighted material of Insurance Services Office, Inc. with its permission.

THIS ENDORSEMENT CHANGES THE POLICY. PLEASE READ IT CAREFULLY.

BLANKET WAIVER OF TRANSFER OF RIGHTS OF RECOVERY

This endorsement modifies insurance provided under the following:

BUSINESS AUTO COVERAGE PART

With respect to coverage provided by this endorsement, the provisions of the Coverage Form apply unless modified by the endorsement.

In the event of any payment for a loss under this Business Auto Coverage Part arising out of your ongoing operations, we agree to waive our rights under the TRANSFER OF RIGHTS OF RECOVERY AGAINST OTHERS TO US condition against any person or organization, its subsidiaries, directors, agents or employees, for which you have agreed by written contract, prior to the occurrence of any loss, to waive such rights, except when the payment results from the sole negligence of that person or organization, its subsidiaries, directors, agents or employees.

Includes copyrighted material of Insurance Services Office, Inc. with its permission.

CA-F-128 (03-03)

Policy Number: 9024732

Transaction Effective Date:06-03-2021

THIS ENDORSEMENT CHANGES THE POLICY. PLEASE READ IT CAREFULLY.

**PRIMARY AND NONCONTRIBUTORY -
OTHER INSURANCE CONDITION**

This endorsement modifies insurance provided under the following:

COMMERCIAL GENERAL LIABILITY COVERAGE PART
LIQUOR LIABILITY COVERAGE PART
PRODUCTS/COMPLETED OPERATIONS LIABILITY COVERAGE PART

The following is added to the **Other Insurance** Condition and supersedes any provision to the contrary:

Primary And Noncontributory Insurance

This insurance is primary to and will not seek contribution from any other insurance available to an additional insured under your policy provided that:

- (1) The additional insured is a Named Insured under such other insurance; and

- (2) You have agreed in writing in a contract or agreement that this insurance would be primary and would not seek contribution from any other insurance available to the additional insured.

THIS ENDORSEMENT CHANGES THE POLICY. PLEASE READ IT CAREFULLY.

**ADDITIONAL INSURED - OWNERS, LESSEES OR
CONTRACTORS - AUTOMATIC STATUS WHEN
REQUIRED IN A WRITTEN CONSTRUCTION
AGREEMENT WITH YOU**

This endorsement modifies insurance provided under the following:

COMMERCIAL GENERAL LIABILITY COVERAGE PART

A. Section II - Who Is An Insured is amended to include as an additional insured any person or organization for whom you are performing operations when you and such person or organization have agreed in writing in a contract or agreement that such person or organization be added as an additional insured on your policy. Such person or organization is an additional insured only with respect to liability for "bodily injury", "property damage" or "personal and advertising injury" caused, in whole or in part, by:

1. Your acts or omissions; or
2. The acts or omissions of those acting on your behalf;

in the performance of your ongoing operations for the additional insured.

However, the insurance afforded to such additional insured:

1. Only applies to the extent permitted by law; and
2. Will not be broader than that which you are required by the contract or agreement to provide for such additional insured.

A person's or organization's status as an additional insured under this endorsement ends when your operations for that additional insured are completed.

B. With respect to the insurance afforded to these additional insureds, the following additional exclusions apply:

This insurance does not apply to:

1. "Bodily injury", "property damage" or "personal and advertising injury" arising out of the rendering of, or the failure to render, any professional architectural, engineering or surveying services, including:
 - a. The preparing, approving, or failing to prepare or approve, maps, shop drawings, opinions, reports, surveys, field orders, change orders or drawings and specifications; or
 - b. Supervisory, inspection, architectural or engineering activities.

This exclusion applies even if the claims against any insured allege negligence or other wrongdoing in the supervision, hiring, employment, training or monitoring of others by that insured, if the "occurrence" which caused the "bodily injury" or "property damage", or the offense which caused the "personal and advertising injury", involved the rendering of or the failure to render any professional architectural, engineering or surveying services.

2. "Bodily injury" or "property damage" occurring after:

- a. All work, including materials, parts or equipment furnished in connection with such work, on the project (other than service, maintenance or repairs) to be performed by or on behalf of the additional insured(s) at the location of the covered operations has been completed; or
- b. That portion of "your work" out of which the injury or damage arises has been put to its intended use by any person or organization other than another contractor or subcontractor engaged in performing operations for a principal as a part of the same project.

C. With respect to the insurance afforded to these additional insureds, the following is added to **Section III - Limits Of Insurance:**

The most we will pay on behalf of the additional insured is the amount of insurance:

- 1. Required by the contract or agreement you have entered into with the additional insured; or
- 2. Available under the applicable limits of insurance;

whichever is less.

This endorsement shall not increase the applicable limits of insurance.

THIS ENDORSEMENT CHANGES THE POLICY. PLEASE READ IT CAREFULLY.

**WAIVER OF TRANSFER OF RIGHTS OF RECOVERY
AGAINST OTHERS TO US (WAIVER OF SUBROGATION) -
AUTOMATIC**

This endorsement modifies insurance provided under the following:

COMMERCIAL GENERAL LIABILITY COVERAGE PART
ELECTRONIC DATA LIABILITY COVERAGE PART
LIQUOR LIABILITY COVERAGE PART
POLLUTION LIABILITY COVERAGE PART DESIGNATED SITES
POLLUTION LIABILITY LIMITED COVERAGE PART DESIGNATED SITES
PRODUCTS/COMPLETED OPERATIONS LIABILITY COVERAGE PART
RAILROAD PROTECTIVE LIABILITY COVERAGE PART
UNDERGROUND STORAGE TANK POLICY DESIGNATED TANKS

The following is added to Paragraph 8. **Transfer Of Rights Of Recovery Against Others To Us** of Section IV - **Conditions:**

We waive any right of recovery against any person or organization, because of any payment we make under this Coverage Part, to whom the insured has waived its right of recovery in a written contract or agreement. Such waiver by us applies only to the extent that the insured has waived its right of recovery against such person or organization prior to loss.

Certificate Of Completion

Envelope Id: 8F246C871EF940E5A0EA4937D2DC6F43	Status: Completed
Subject: Please DocuSign: COG-CON-22-857_-_Crescent_Electric.pdf	
Source Envelope:	
Document Pages: 33	Signatures: 3
Certificate Pages: 5	Initials: 0
AutoNav: Enabled	Stamps: 1
Envelope Stamping: Enabled	Envelope Originator:
Time Zone: (UTC-06:00) Central Time (US & Canada)	Janelle Williams
	823 Rosenberg
	Galveston, TX 77550
	CitySec@galvestontx.gov
	IP Address: 50.205.209.26

Record Tracking

Status: Original 04-29-2022 10:13	Holder: Janelle Williams CitySec@galvestontx.gov	Location: DocuSign
Security Appliance Status: Connected	Pool: StateLocal	
Storage Appliance Status: Connected	Pool: City of Galveston	Location: DocuSign

Signer Events

Donna Fairweather for
Legal@galvestontx.gov
City Attorney
Security Level: Email, Account Authentication (None)

Signature

DocuSigned by:
Donna Fairweather for
6A59EBFC33E04AD...
Signature Adoption: Pre-selected Style
Signed by link sent to Legal@galvestontx.gov
Using IP Address: 50.205.209.26

Timestamp

Sent: 04-29-2022 | 10:16
Viewed: 04-29-2022 | 13:20
Signed: 04-29-2022 | 13:21

Electronic Record and Signature Disclosure:
Accepted: 04-29-2022 | 13:20
ID: ba07e509-0f9e-42aa-acd5-f35328106e59

Daniel J. Buckley; For
CityManager@galvestontx.gov
Deputy City Manager
Security Level: Email, Account Authentication (None)

DocuSigned by:
Daniel J. Buckley; For
88F906B399D042A...
Signature Adoption: Pre-selected Style
Signed by link sent to CityManager@galvestontx.gov
Using IP Address: 50.205.209.26

Sent: 04-29-2022 | 13:21
Viewed: 04-29-2022 | 13:35
Signed: 04-29-2022 | 13:36

Electronic Record and Signature Disclosure:
Accepted: 04-29-2022 | 13:35
ID: bffb7e24-9e66-4cc7-b76f-638d1cc72a38

Janelle Williams
citysec@galvestontx.gov
City Secretary
City of Galveston
Security Level: Email, Account Authentication (None)

DocuSigned by:
Janelle Williams
F12778E17F2948B...

Signature Adoption: Pre-selected Style
Signed by link sent to citysec@galvestontx.gov
Using IP Address: 50.205.209.26

Sent: 04-29-2022 | 13:36
Viewed: 04-29-2022 | 13:54
Signed: 04-29-2022 | 13:55

Electronic Record and Signature Disclosure:
Not Offered via DocuSign

In Person Signer Events

Signature

Timestamp

Editor Delivery Events	Status	Timestamp
-------------------------------	---------------	------------------

Agent Delivery Events	Status	Timestamp
------------------------------	---------------	------------------

Intermediary Delivery Events	Status	Timestamp
-------------------------------------	---------------	------------------

Certified Delivery Events	Status	Timestamp
----------------------------------	---------------	------------------

Carbon Copy Events	Status	Timestamp
---------------------------	---------------	------------------

Witness Events	Signature	Timestamp
-----------------------	------------------	------------------

Notary Events	Signature	Timestamp
----------------------	------------------	------------------

Envelope Summary Events	Status	Timestamps
--------------------------------	---------------	-------------------

Envelope Sent	Hashed/Encrypted	04-29-2022 10:16
Certified Delivered	Security Checked	04-29-2022 13:54
Signing Complete	Security Checked	04-29-2022 13:55
Completed	Security Checked	04-29-2022 13:55

Payment Events	Status	Timestamps
-----------------------	---------------	-------------------

Electronic Record and Signature Disclosure

ELECTRONIC RECORD AND SIGNATURE DISCLOSURE

From time to time, City of Galveston - City Secretary Office (we, us or Company) may be required by law to provide to you certain written notices or disclosures. Described below are the terms and conditions for providing to you such notices and disclosures electronically through the DocuSign system. Please read the information below carefully and thoroughly, and if you can access this information electronically to your satisfaction and agree to this Electronic Record and Signature Disclosure (ERSD), please confirm your agreement by selecting the check-box next to 'I agree to use electronic records and signatures' before clicking 'CONTINUE' within the DocuSign system.

Getting paper copies

At any time, you may request from us a paper copy of any record provided or made available electronically to you by us. You will have the ability to download and print documents we send to you through the DocuSign system during and immediately after the signing session and, if you elect to create a DocuSign account, you may access the documents for a limited period of time (usually 30 days) after such documents are first sent to you. After such time, if you wish for us to send you paper copies of any such documents from our office to you, you will be charged a \$0.00 per-page fee. You may request delivery of such paper copies from us by following the procedure described below.

Withdrawing your consent

If you decide to receive notices and disclosures from us electronically, you may at any time change your mind and tell us that thereafter you want to receive required notices and disclosures only in paper format. How you must inform us of your decision to receive future notices and disclosure in paper format and withdraw your consent to receive notices and disclosures electronically is described below.

Consequences of changing your mind

If you elect to receive required notices and disclosures only in paper format, it will slow the speed at which we can complete certain steps in transactions with you and delivering services to you because we will need first to send the required notices or disclosures to you in paper format, and then wait until we receive back from you your acknowledgment of your receipt of such paper notices or disclosures. Further, you will no longer be able to use the DocuSign system to receive required notices and consents electronically from us or to sign electronically documents from us.

All notices and disclosures will be sent to you electronically

Unless you tell us otherwise in accordance with the procedures described herein, we will provide electronically to you through the DocuSign system all required notices, disclosures, authorizations, acknowledgements, and other documents that are required to be provided or made available to you during the course of our relationship with you. To reduce the chance of you inadvertently not receiving any notice or disclosure, we prefer to provide all of the required notices and disclosures to you by the same method and to the same address that you have given us. Thus, you can receive all the disclosures and notices electronically or in paper format through the paper mail delivery system. If you do not agree with this process, please let us know as described below. Please also see the paragraph immediately above that describes the consequences of your electing not to receive delivery of the notices and disclosures electronically from us.

How to contact City of Galveston - City Secretary Office:

You may contact us to let us know of your changes as to how we may contact you electronically, to request paper copies of certain information from us, and to withdraw your prior consent to receive notices and disclosures electronically as follows:

To contact us by email send messages to: CitySec@galvestontx.gov

To advise City of Galveston - City Secretary Office of your new email address

To let us know of a change in your email address where we should send notices and disclosures electronically to you, you must send an email message to us at citysec@galvestontx.gov and in the body of such request you must state: your previous email address, your new email address. We do not require any other information from you to change your email address.

If you created a DocuSign account, you may update it with your new email address through your account preferences.

To request paper copies from City of Galveston - City Secretary Office

To request delivery from us of paper copies of the notices and disclosures previously provided by us to you electronically, you must send us an email to jwilliams@galvestontx.gov and in the body of such request you must state your email address, full name, mailing address, and telephone number. We will bill you for any fees at that time, if any.

To withdraw your consent with City of Galveston - City Secretary Office

To inform us that you no longer wish to receive future notices and disclosures in electronic format you may:

- i. decline to sign a document from within your signing session, and on the subsequent page, select the check-box indicating you wish to withdraw your consent, or you may;
- ii. send us an email to CitySec@galvestontx.gov and in the body of such request you must state your email, full name, mailing address, and telephone number. We do not need any other information from you to withdraw consent.. The consequences of your withdrawing consent for online documents will be that transactions may take a longer time to process..

Required hardware and software

The minimum system requirements for using the DocuSign system may change over time. The current system requirements are found here: <https://support.docusign.com/guides/signer-guide-signing-system-requirements>.

Acknowledging your access and consent to receive and sign documents electronically

To confirm to us that you can access this information electronically, which will be similar to other electronic notices and disclosures that we will provide to you, please confirm that you have read this ERSD, and (i) that you are able to print on paper or electronically save this ERSD for your future reference and access; or (ii) that you are able to email this ERSD to an email address where you will be able to print on paper or save it for your future reference and access. Further, if you consent to receiving notices and disclosures exclusively in electronic format as described herein, then select the check-box next to 'I agree to use electronic records and signatures' before clicking 'CONTINUE' within the DocuSign system.

By selecting the check-box next to 'I agree to use electronic records and signatures', you confirm that:

- You can access and read this Electronic Record and Signature Disclosure; and
- You can print on paper this Electronic Record and Signature Disclosure, or save or send this Electronic Record and Disclosure to a location where you can print it, for future reference and access; and
- Until or unless you notify City of Galveston - City Secretary Office as described above, you consent to receive exclusively through electronic means all notices, disclosures, authorizations, acknowledgements, and other documents that are required to be provided or made available to you by City of Galveston - City Secretary Office during the course of your relationship with City of Galveston - City Secretary Office.



City of Galveston

PUBLIC WORKS & UTILITIES

Tyson Arnold, P.E., Interim Executive Director - Public Works & Utilities
jarnold@galvestontx.gov | Office Number: (409) 797-3640 | www.galvestontx.gov

Date: February 27, 2025
To: City Manager
Mayor and City Council Members
From: Tyson Arnold, P.E.
Interim Executive Director - Public Works & Utilities
Project Location: 13706 Stewart Rd. **Project:** N/A

Request:

- A. Consider for approval the acceptance of the BuyBoard contract #757-24 from Foster Fence, for labor and materials for the restoration of the fence at Lift Station 38 in the amount of \$17,596.00. Authorizing the City Manager to execute all necessary documents upon final approval by the City Attorney.

Current Situation:

- A. In July, Hurricane Beryl made landfall, resulting in significant damage to numerous City facilities across the island.
- B. The fence at Lift Station 38, located at 13706 Stewart Rd, sustained extensive wind damage.
- C. To maintain compliance with TCEQ regulations, a complete rebuild of the fence is required.

Fiscal Impact Report:

<u>Funding Source</u>	<u>Amount</u>
S2502	\$ 17,596.00
Total	\$ 17,596.00





City of Galveston

PUBLIC WORKS & UTILITIES

Tyson Arnold, P.E., Interim Executive Director - Public Works & Utilities
jarnold@galvestontx.gov | Office Number: (409) 797-3640 | www.galvestontx.gov

Alternatives:

- A. Approve the BuyBoard purchase of fence material and restoration in the amount of \$17,596.00. Authorizing the City Manager to execute all necessary documents upon final approval by the City Attorney.
- B. Do not approve the request.

Staff Recommendation:

Approve the acceptance of the BuyBoard contract #757-24 from Foster Fence, for labor and materials for the restoration of the fence at Lift Station 38 in the amount of \$17,596.00. Authorizing the City Manager to execute all necessary documents upon final approval by the City Attorney.

Attachments:

Lift Station 38 Fence Quote





Quote: 2CM28JAN25

To: City of Galveston

Attention: Mike Sumrall

Project: Lift Station 38

Date: 01/28/2025

Foster Fence will provide the following:

UYBOARD # 757-24

-Demo/Remove 155 linear ft of existing Chain Link Fence and gate.

-Install 155 linear ft of new 7' OA galvanized chain link fence. 2" x 2oz chain link fabric. 3' sch40 terminal posts with 1-5/8" sch40 brace & truss, 2-3/8" sch40 line posts, 1-5/8" sch40 top rail, 7ga tension wire on bottom.

-Install one 12' double swing gate to match fence with 4" sch40 gate posts.

-Install green PVC slats in fence and gates.

***Lead times are projected after submittals are approved**

Total - \$17,596.00* - Tax not included

Estimated Taxes (if applicable) - \$0.00

***Quotes are good for 30 days**

Estimator: Carter Morby - 713-204-8671 - cmorby@fosterfence.com

Members of: Avetta, ISNetworld, Houston Area Safety Council and C3 Accredited

Exclusions - unless specifically included in quote:

(281) 456-7273
(281) 456-0221 Fax

FOSTER FENCE LTD
P.O. BOX 96116
Houston, TX 77213

www.fosterfence.com
info@fosterfence.com



- * Work to be performed during standard business hours, 7am-5pm Monday through Friday. Any work that needs to be performed after hours or on the weekend will come at an added cost and will need to be quoted accordingly.
- * Demolition, clearing & grubbing, spoil removal
- * Electrical work, access controls, and conduits
- * Fence and controls grounding.
- * Engineered drawings and Building Information Modeling (BIM)
- * Fence or fire department permitting.
- * Property surveying and site layout. The final location of the fence installation is to be verified with the customer/agent and Foster Fence staff before starting the installation.
- * Tree protection, silt fence, temporary fence.
- * Hand digging, hydro-excavation, core drilling, rock drilling, probing.
- * Concrete & asphalt breaks.
- * Signage, bollards, concrete mow strip.
- * Painting, staining, galvanizing after fabrication.
- * Utility locates beyond 811 One call, location of water lines. Private utility lines are not covered by 811. Locating private lines is the responsibility of the property owner.
- * OQ training, OSHA 30 Training, site or hazard specific training greater than 30 minutes
- * Remobilizations, down time, standby time.
- * OCIP, CCIP, Builders Risk, Payment and Performance Bonds

Commerical Conditions

- * All projects requiring special fabrication as well as contracts with a value greater than \$75,000 will require signed and approved submittals before Foster Fence, Ltd. proceeds with construction.
- * Lead times are projected after submittals are approved.
- * Terms - Net 30, unless otherwise expressly negotiated
- * All standy/down time in excess of 30 minutes will be billed at a rate of \$400 per hour.
- * Restocking fee for standard stock materials 25%, non-stock materials 100%
- * Foster Fence Ltd. agrees to guarantee all materials to be free from defects in materials and workmanship for a period of one year from installation. This guarantee does not cover abuse, Acts of God, Nature, or other external source.

CUSTOMER SIGNATURE

DATE



City of Galveston

PUBLIC WORKS & UTILITIES

Tyson Arnold, P.E., Interim Executive Director - Public Works & Utilities
jarnold@galvestontx.gov | Office Number: (409) 797-3640 | www.galvestontx.gov

Date: February 27, 2025

To: City Manager
Mayor and City Council Members

From: Tyson Arnold, P.E.
Interim Executive Director - Public Works & Utilities

Project Location: N/A **Project:** Laboratory Water Quality Sampling Contract

Request:

- A. Consider for approval awarding a 3-year contract for the services of conducting laboratory sampling for the Water Supply and Wastewater Treatment divisions (Bid 25-05) to Eastex Environmental Laboratory, Inc., in the amount of \$106,846.00. Authorizing the City Manager to execute all necessary documents upon final approval by the City Attorney.

Background:

- A. The City of Galveston issues a contract for laboratory sampling to allow staff to analyze wastewater quality to ensure that the City remains in compliance with TCEQ and EPA's requirements, as referenced in the Clean Water Drinking Act.
- B. In 2018, the City renewed the annual contract to conduct laboratory sampling for the Wastewater Treatment division.
- C. The use of a contract reduces the turn-around time as quotes are required for all purchases over \$1,000.00.
- D. Laboratory samples taken differ by division and sample type.

Current Situation:

- A. The scope of this contract was expanded to include the Water Supply division laboratory sampling in addition to the Wastewater Treatment division's scope outlined in the previous contract.





City of Galveston

PUBLIC WORKS & UTILITIES

Tyson Arnold, P.E., Interim Executive Director - Public Works & Utilities
jarnold@galvestontx.gov | Office Number: (409) 797-3640 | www.galvestontx.gov

- B. Sealed bids were opened on January 13th, 2025, at 10:00 a.m. There were approximately 22 bid items on the bid proposal for Water Quality Laboratory Sampling. There were three (3) bids submitted. Based on the bids submitted Staff recommends a contract be awarded to Eastex Environmental Laboratory, Inc. in the amount of \$106,846.00.
- C. The bids and contracts will be effective for three (3) years from the date of award and shall automatically renew for two (2) successive one (1) year periods under the existing terms and conditions of the contract, unless either party gives the other party written notice of non-renewal at least 30 days prior to such renewal date.

Fiscal Impact Report:

<u>Funding Source</u>	<u>Amount</u>
Combined Utility Fund	\$ 106,846.00
(70% Treatment/30% Supply) – Lab Testing	
Total	\$ 106,846.00

Alternatives:

- A. Approve awarding a 3-year contract for the services of conducting laboratory sampling for the Water Supply and Wastewater Treatment divisions (Bid 25-05) to Eastex Environmental Laboratory, Inc., in the amount of \$106,846.00. Authorizing the City Manager to execute all necessary documents upon final approval by the City Attorney.
- B. Do not approve the request.

Staff Recommendation:

Approve awarding a 3-year contract for the services of conducting laboratory sampling for the Water Supply and Wastewater Treatment divisions (Bid 25-05) to Eastex Environmental Laboratory, Inc., in the amount of \$106,846.00. Authorizing the City Manager to execute all necessary documents upon final approval by the City Attorney.

Attachments:

Bid 25-05 – Bid Tabulation



Bid 25-05
 10:00A.M., Monday January 14, 2025
 Opened By: Ja'Nice Lockett

Laboratory Water Quality Sampling
 TEAMS Meeting

OFFEROR	Eastex Environmental Laboratory, Inc.	Envirodyne Laboratories Inc	Eurofins Environment Testing South Central, LLC (Eurofins Houston)	North Water District Laboratory Services, Inc.
Received Date and Time	1/9/2025 4:44:01 PM	1/10/2025 10:52:28 AM	1/13/2025 9:07:06 AM	1/13/2025 9:38:16 AM
	Received Document (Y/N)	Received Document (Y/N)	Received Document (Y/N)	Received Document (Y/N)
Responsive?	Y	Y	Y	Y
Appendix A	Y	Y	Y	Y
Appendices B, C, D, E, F, G,	Y	Y	Y	Y
Appendix H ACH) (not required)				
Price Sheets	Y	Y	Y	Y

PRICING

OFFEROR	Eastex Environmental Laboratory, Inc.	Envirodyne Laboratories Inc	Eurofins Environment Testing South Central, LLC (Eurofins Houston)	North Water District Laboratory Services, Inc.
CBOD ₅	\$ 12.00	\$ 17.50	\$ 18.00	\$ 15.00
Total Suspended Solids	\$ 7.00	\$ 14.00	\$ 8.00	\$ 10.00
Ammonia as Nitrogen	\$ 9.00	\$ 16.50	\$ 15.00	\$ 15.00
Enterococcus	\$ 12.00	\$ 20.00	\$ 22.00	\$ 20.00
Fecal Coliform	\$ 9.00	\$ 20.00	\$ 22.00	\$ 20.00
Copper	\$ 10.00	\$ 16.00	\$ 10.00	\$ 10.00
Priority Pollutant Scan	\$ 800.00	\$ 950.00	\$ 375.00	\$ 800.00
Toxicity Characteristic Leaching Procedures (TCLP)	\$ 700.00	\$ 895.00	\$ 430.00	\$ 750.00
Paint Filter Test	\$ 10.00	\$ 10.00	\$ 10.00	\$ 10.00
Soil Samples	\$ 600.00	\$ 460.00	\$ 250.00	\$ 825.00
Metals, Cyanide, and Phenols	\$ 200.00	\$ 420.00	\$ 350.00	\$ 350.00
Oil and grease	\$ 10.00	\$ 35.00	\$ 30.00	\$ 20.00
Chemical Oxygen Demand (COD)	\$ 10.00	\$ 17.00	\$ 15.00	\$ 20.00
Chronic Americamysis Bahia	\$ 550.00	\$ 840.00	\$ 900.00	\$ 750.00
Chronic Menidia Beryllina	\$ 550.00	\$ 840.00	\$ 900.00	\$ 750.00
Acute Americamysis Bahia	\$ 60.00	\$ 140.00	\$ 400.00	\$ 100.00
Acute Menidia Beryllina	\$ 60.00	\$ 140.00	\$ 400.00	\$ 100.00
TTHMs	\$ 95.00	\$ 140.00	\$ 55.00	\$ 150.00
HAA5s	\$ 140.00	\$ 305.00	\$ 65.00	\$ 400.00
Total Coliform	\$ 15.00	\$ 15.50	\$ 22.00	\$ 15.00
Nitrate as N	\$ 15.00	\$ 24.00	\$ 10.00	\$ 10.00
Nitrite as N	\$ 15.00	\$ 24.00	\$ 10.00	\$ 10.00
Total Annual Spend	\$ 106,846.00	\$ 168,964.00	\$ 152,498.00	\$ 148,410.00
Option Renewal (YR 4&5) Escalator	4%	4%	4%	0%

DRAFT
MINUTES OF THE CITY COUNCIL OF THE CITY OF GALVESTON
JOINT MEETING OF CITY COUNCIL AND WHARVES BOARD

1/9/2025 - Minutes

1. DECLARATION OF A QUORUM AND CALL MEETING TO ORDER

With a quorum present, the meeting was called to order at 9:00 a.m.

2. ROLL CALL

Council Members Present: Mayor Craig Brown, Mayor Pro Tem Marie Robb, Council Member Sharon Lewis, Council Member David Finklea, Council Member Bob Brown, Council Member Alex Porretto, and Council Member Beau Rawlins.

Wharves Board Member Present: Chair Victor Pierson, Vice Chair Jeff Patterson, Trustee Willy Gonzalez, Trustee Sheila Lidstone, Trustee Jim Yarbrough, Trustee Mayor Craig Brown, and Trustee Richard Moore.

3. DISCUSSION ITEMS

3.A. Discussion Of The City Charter As It Relates To The Port Of Galveston

Discussion was held regarding the City of Galveston's oversight of the Wharves Board and the Port of Galveston, with an emphasis on the following key points: (1) City Charter Oversight - The City Council appoints Wharves Board members and approves the Port's debt service, with oversight duties outlined in the City Charter. Concerns were raised about a lack of reporting since 2014 as required by the charter. (2) Accountability and Transparency - The need for better transparency was emphasized, with a focus on ensuring reports and records are provided to the Council as required by the charter. (3) Financial and Payments - Discussions included payments from the Port to the City, particularly for infrastructure projects like the 14th Street Pump Station, and future payment expectations; (4) Competitive Bidding - The Port's bidding process was discussed, especially the use of "best value" in contractor selection. The goal is to improve oversight, transparency, and compliance with the City Charter while ensuring that the Port benefits the community.

3.B. Discussion Of A One Time And Annual, Long Term, Recurring Funding Stream From The Port To The City (C Brown/Pierson)

1. History
2. Current Funding
3. Funding from the City to the Port of Galveston
4. Reserve funding status
5. Payment request of a one-time special dividend to the City of Galveston in the City's 2024-2025 Fiscal Year(Porretto/Rawlins)
6. Future Funding Mechanisms
7. Creation of an ad hoc committee to determine a dividend payment structure (Porretto/Rawlins)

The discussion involved a review of the financial relationship between the Port of Galveston and the City of Galveston. Key points discussed included: (1) Historical Funding - The City receives funds from the Port, including a \$0.25 per turn per passenger fee and parking-related sales tax revenue. The Port's financial contributions are increasing, with expected further growth due to Cruise Terminal 16; (2) Current Funding - The Port has provided about \$3 million in 2024, with future increases expected. There were missed opportunities, such as

potential partnerships in the parking garage, which could have generated further revenue for the City; (3) Funding from City to Port - Over the years, the City has contributed to the Port in the form of economic development funds, infrastructure support, and capital projects; (4) Future Funding - There's a discussion of creating an ad hoc committee to decide on a future dividend payment structure, ensuring that both parties work together for long-term mutual benefit.

3.C. Update And Discussion Of The Port's Master Plan And Related Future Plans (C Brown/Pierson)

1. Cruise Lines - Number/Expansion/Timing/Moratorium of Additional Cruise Terminals and or Cruise Ships - Discussion was held and concerns raised about talks of pausing new cruise terminal development, pending an updated master plan, that could harm business momentum. The focus is on revising the master plan to reflect current developments, like cruise terminals and cargo operations, while considering limited Port space.

2. Cargo Business - Port Director Rodger Rees reported that the Port is heavily investing in its west cargo complex, with nearly \$100 million earmarked for redevelopment. Cargo business revenues are growing, but they still lag behind cruise terminal revenues.

3. Pelican Island Development - The discussion centers around the development of Pelican Island and its connection to the bridge project, which is crucial for both the port and the city. There's anticipation for discussing these developments in more detail. A preliminary draft of the AFA contract for the bridge is expected by January 2013, with the Mayor Pro Tem leading the push for additional funding to cover any deficits. The goal is to finalize agreements by April, though environmental concerns are the main obstacle slowing down the process. The projected completion date for the project is 2034, but there is hope that this timeline could be expedited.

3.D. Discussion Of The Port Of Galveston's Financial Status Resulting In A Detailed Financial Report From The Port Of Galveston Outlining The Current Available Sources And Uses Of Funds For The Next 36 Months (Porretto/Rawlins)

Port of Galveston staff provided Council with a detailed financial report outlining the available funds and how they will be used over the next 36 months. The document highlighting the Port's financial projections and planned projects was noted as very informative, and Council members were encouraged to review it closely. There was also a suggestion to further discuss the information among the Council to ensure clarity and agree on any additional requests for more details.

3.E. Update And Discussion Of The Wharves Board's Real Estate Committee (B Brown/C Brown)

The discussion revolved around the formation and update of the Wharves Board's Real Estate Committee. The committee's mission is to explore opportunities for collaboration between the City, Port, and third parties. They aim to develop areas that are attractive to both residents and tourists, ensuring compliance with all laws, policies, and plans. It was clarified that the committee is not a decision-making body but will report back to the City Council and Port Board with its findings. The issue of how Council members were appointed to the committee was raised, with concerns about whether it had been voted on by the Council. The committee intends to help inform the Port's master plan by addressing specific development issues.

3.F. Port Updates

1. Galveston County Property Tax Case - Port Attorney Tony Brown reported that Galveston County has filed lawsuits concerning taxes on the Galveston Cruise Terminal. The core issue is whether Galveston Cruise Terminal or the Port owns the terminal's improvements, which affects who should pay taxes. The Port argues it owns the improvements and the taxes should be the Port's responsibility, but if the terminal is taxed, part of the revenue goes to the

state rather than the local district. If the lawsuit is unsuccessful, it could set a precedent making all port-leased properties taxable, which could cause statewide issues.

2. EPA Negotiations - Port Attorney Tony Brown reported that the Port had been negotiating with the EPA over hazardous waste disposal regulations. Initially, the City was considered a party, but the EPA now says it's not needed as a party in the matter.

3. Procurement Bid Processes - Port Attorney Tony Brown advised there are legal considerations on local vendor preferences, as state laws limit when these preferences can apply. The ambiguity exists, but it should be fine as long as there's an established policy in place.

- 3.G. Discussion Of A Resolution Or Policy Requiring The Wharves Board Of Trustees Inform The Galveston City Council On Filed, Pending, Or Potential Lawsuits At The Next Regularly Scheduled Galveston City Council Meeting Upon Notification Of Said Lawsuit (Porretto/Rawlins)

Discussion was held regarding creating a policy or resolution requiring the Wharves Board of Trustees to inform the Galveston City Council about any filed, pending, or potential lawsuits during the next regularly scheduled City Council meeting after receiving notification about a lawsuit. The goal is to keep the Council updated on legal matters that could affect the Port's physical and financial condition, and ensure everyone is on the same page. One concern raised is the potential confidentiality of sensitive lawsuits, with suggestions to collaborate on a mechanism to protect this information while keeping the Council informed.

- 3.H. Discussion Of The Port's 200 Year Anniversary Celebration (Pierson/C Brown)

Port Director Rodger Rees reported on the upcoming 200th anniversary celebration of the Port of Galveston. The celebration kicks off on May 22nd with an observance of Maritime Day, followed by a golf tournament on October 16th. The main celebration events on October 17th and 18th will feature public activities, live music, and possibly some Juneteenth-related programming. The Port's anniversary celebration has garnered significant support from local businesses, cruise lines, and other port-related partners. The overall budget for the celebration is estimated between \$500,000 and \$600,000, but no port revenue or taxpayer money will be used. The event aims to showcase the port's historical significance and its positive impact on the community, culminating in a large gala at the San Luis Hotel. The Port aims to raise funds for scholarships, using any leftover money after the event.

4. ADJOURNMENT

The meeting was adjourned at 12:20 p.m.

Janelle Williams, City Secretary

Date Approved:

RESOLUTION NO. 25 - ____

A RESOLUTION OF THE CITY COUNCIL OF THE CITY OF GALVESTON, TEXAS, RELATED TO THE DISPOSITION OF L.A. MORGAN SCHOOL; EXPRESSING SUPPORT FOR THE GALVESTON INDEPENDENT SCHOOL DISTRICT TRUSTEES TO CONSIDER ALTERNATIVE USE PLANS FOR THE L.A. MORGAN SCHOOL SITE, WHICH COULD INCLUDE A NATIONAL JUNETEENTH MUSEUM, AND/OR A COMMUNITY PARK; PROVIDING FOR FINDINGS OF FACT AND PROVIDING FOR AN EFFECTIVE DATE.

WHEREAS, Galveston Independent School District Trustees have closed L.A. Morgan School and have declared the land and improvements at the site to be surplus property to be disposed of by sale; and

WHEREAS, the L.A. Morgan School site holds historical and cultural significance for the community of Galveston; and

WHEREAS, the City Council recognizes the importance of utilizing this site to benefit current and future generations while honoring its historical legacy; and

WHEREAS, the City Council believes there are many alternative uses for the site which could include the development of a National Juneteenth Museum to celebrate and educate about the history and legacy of Juneteenth; a community park to provide accessible recreational opportunities and enhance community well-being; or other uses which could be developed through community input; and

WHEREAS, these potential uses align with the City of Galveston's goals for cultural preservation, economic growth, and environmental sustainability;

WHEREAS, the City Council of the City of Galveston, Texas, deems it in the best interest of the City and its residents to support this Resolution as provided herein.

NOW, THEREFORE, BE IT RESOLVED BY THE CITY COUNCIL OF THE CITY OF GALVESTON, TEXAS:

SECTION 1. The findings and recitations set out in the preamble to this Resolution are found to be true and correct and are hereby adopted by the City Council and made a part hereof for all purposes.

SECTION 2. The City Council expresses its support of the concept that the Galveston Independent School District Trustees consider proposals from the community for any future use of the L.A. Morgan School property to allow development of the site to be a center of community involvement for future generations.

SECTION 3. The City Council encourages community organizations to present their thoughts on development of the L.A. Morgan site so they may be considered by the GISD Trustees as they make their decisions on the future of the property.

SECTION 4. The City Council affirms its commitment that the public should be a part of public decision making through hearings, forums, and other participatory opportunities, which are all part of the civic involvement all citizens should have available to them.

SECTION 5. The City Secretary shall send a certified copy of this Resolution to the GISD Trustees Board.

SECTION 6. This Resolution shall be and become effective from and after its adoption.

APPROVED AS TO FORM:

DONALD GLYWASKY
CITY ATTORNEY

I, Janelle Williams, Secretary of the City Council of the City of Galveston, do hereby certify that the foregoing is a true and correct copy of a Resolution adopted by the City Council of the City of Galveston at its Regular meeting held on February 27, 2025, as the same appears in records of this office.

IN TESTIMONY WHEREOF, I subscribe my name hereto officially under the corporate seal of the City of Galveston this _____ day of _____, 2025.

Secretary for the City Council
of the City of Galveston

RESOLUTION NO. 25 - ____

AN ORDINANCE OF THE CITY OF GALVESTON, TEXAS, CREATING A COMPREHENSIVE PLAN STEERING COMMITTEE FOR THE CITY OF GALVESTON; PROVIDING FOR A COMMITTEE OF FOURTEEN (14) MEMBERS; CHARGING THE COMMITTEE TO REVIEW THE CITY'S COMPREHENSIVE PLAN, TO PROVIDE INPUT AND FEEDBACK OF LONG-RANGE GOALS AND POLICIES AFFECTING THE CITY, AND TO PROVIDE RECOMMENDATIONS AS MAY BE APPROPRIATE; PROVIDING FOR FINDINGS OF FACT AND FOR AN EFFECTIVE DATE.

WHEREAS, the purpose of a Comprehensive Plan is to provide a statement of long-range goals and policies affecting the City's competitiveness, livability, and sustainability, to provide objectives, and strategies for the community's long-term conservation, growth, and development; and,

WHEREAS, the city's Comprehensive Plan forms the basis upon which zoning decisions are made and are required pursuant to Local Government Code (LGC) Chapter 211. In Texas, a Comprehensive Plan is required for a city to adopt zoning regulations; and,

WHEREAS, it is recommended to review a city's Comprehensive Plan approximately each five (5) to ten (10) years for continued guidance of local decision-makers and stakeholders, toward meeting the City's Comprehensive Plan goals and objectives; and,

WHEREAS, in accordance with LGC Chapter 213, the City Council at its Council workshop meeting of December 12, 2024, discussed the composition of the Comprehensive Plan Steering Committee for the Comprehensive Plan update; and,

WHEREAS, the Comprehensive Plan Steering Committee will be a diverse collective of community members that represent different districts, demographics, and varying backgrounds of expertise within the City of Galveston. These committee members will provide input and feedback on each element of the planning process, including preliminary plan vision and goals, guiding principles, base concept development and strategies, element policies and priority actions, implementation strategies and recommendations; and,

WHEREAS, each member of City Council shall name two (2) persons to be a member of the "2025 Comprehensive Plan Steering Committee", for a total of fourteen (14) members; and,

WHEREAS, the City Council of the City of Galveston, Texas, deems it in the public interest to form a fourteen member, 2025 Comprehensive Plan Steering Committee.

NOW, THEREFORE, BE IT RESOLVED BY THE CITY COUNCIL OF THE CITY OF GALVESTON, TEXAS:

SECTION 1. The findings and recitations set out in the preamble to this Resolution are found to be true and correct and they are hereby adopted by the City Council and made a part hereof for all purposes.

SECTION 2. There is hereby created a committee designated as the “2025 Comprehensive Plan Steering Committee” (Steering Committee). The committee members will provide input and feedback on each element of the planning process, including preliminary plan vision and goals, guiding principles, base concept development and strategies, element policies and priority actions, implementation strategies and make recommendations to City Council.

SECTION 3. The Steering Committee shall be made up of fourteen (14) members appointed by City Council. A member must be a resident of the City but need not reside in the district of the Councilmember who appoints that person. The fourteen (14) members appointed at large by the City Council are:

- | | | |
|-----------------------------|---------|----------|
| Mayoral Appointments | 1)_____ | 2)_____ |
| District One Appointments | 1)_____ | 2)_____ |
| District Two Appointments | 1)_____ | 2)_____ |
| District Three Appointments | 1)_____ | 2)_____ |
| District Four Appointments | 1)_____ | 2)_____ |
| District Five Appointments | 1)_____ | 2)_____ |
| District Six Appointments; | 1)_____ | 2)_____; |

and,

SECTION 5. The Committee shall convene as soon as practicable after the appointment of its members by City Council. They will upon their first meeting select a chair (and a vice-chair to serve in absence of the chair), to schedule and conduct all meetings. All meetings will be scheduled in compliance with the provisions of the Open Meetings Act, will be conducted in City Hall and will be open to the public. Each meeting will include an opportunity for public comment.

SECTION 6. This Resolution shall be and become effective from and after its adoption.

APPROVED AS TO FORM:

DONNA M. FAIRWEATHER
SR. ASST. CITY ATTORNEY

I, Janelle Williams, Secretary of the City Council of the City of Galveston, do hereby certify that the foregoing is a true and correct copy of an Resolution adopted by the City Council

of the City of Galveston at its Regular meeting held on February 27, 2025, as the same appears in records of this office.

IN TESTIMONY WHEREOF, I subscribe my name hereto officially under the corporate seal of the City of Galveston this ____ day of _____, 2025.

Secretary for the City Council
of the City of Galveston



City of Galveston

Development Services

Pete Milburn, Sr. Project Manager

Pmilburn@galvestontx.gov | 409.797.3672 | www.galvestontx.gov

Date: February 27, 2025

To: Brian Maxwell, City Manager
Hon. Mayor and City Council Members

From: Pete Milburn, Senior Project Manager

RE: Consider For Approval The Creation Of A Steering Committee Of Fourteen (14) Members; Charging The Committee To Review The City's Comprehensive Plan, To Provide Input And Feedback Of Long-Range Goals and Policies Affecting The City, And To Provide Recommendations As May Be Appropriate.

I. Background

- A. The purpose of a Comprehensive Plan is to provide a statement of long-range goals and policies affecting the City's competitiveness, livability, and sustainability, to provide objectives, and strategies for the community's long-term conservation, growth, and development.
- B. The city's Comprehensive Plan forms the basis upon which zoning decisions are made and are required pursuant to Local Government Code (LGC) Chapter 211. In Texas, a Comprehensive Plan is required for a city to adopt zoning regulations.
- C. It is recommended to review a city's Comprehensive Plan approximately each five (5) to ten (10) years for continued guidance of local decision-makers and stakeholders, toward meeting the City's Comprehensive Plan goals and objectives.
- D. In accordance with LGC Chapter 213, the City Council at its Council workshop meeting of January 23, 2024, discussed the composition of the Comprehensive Plan Steering Committee for the Comprehensive Plan update.

II. Current Situation

- A. The Comprehensive Plan Steering Committee will be a diverse collective of community members that represent different districts, demographics, and varying backgrounds of expertise within the City of Galveston. These committee members will provide input and feedback on each element of the planning process, including preliminary plan vision and goals, guiding principles, base concept development and strategies, element policies and priority actions, implementation strategies and recommendations.
- B. Each member of City Council shall name two (2) persons to be a member of the "Comprehensive Plan Steering Committee", for a total of fourteen (14) members.

III. Alternatives in Order of Priority





City of Galveston

Development Services

Pete Milburn, Sr. Project Manager

Pmilburn@Galvestontx.gov | 409.797.3672 | www.galvestontx.gov

- A. Appointment of a fourteen (14) member Steering Committee.
- B. Do not appoint the Steering Committee.

IV. **Recommendation**

- A. Appoint the fourteen (14) member Comprehensive Plan Steering Committee.

Respectfully Submitted,

Pete Milburn, Senior Project Manager

Approved,

Brian Maxwell
City Manager

